

FLOOR PLAN

SCALE: 1/4" = 1'-0"

A CLEAR FLOOR SPACE COMPLYING WITH 305 POSITIONED FOR A FORWARD APPROACH, KNEE, AND TOE CLEARANCE W/ 306 SHALL BE PROVIDED FOR BREAKROOM SINK AND ADA BATHROOMS
34" MAX SINK RIM HEIGHT

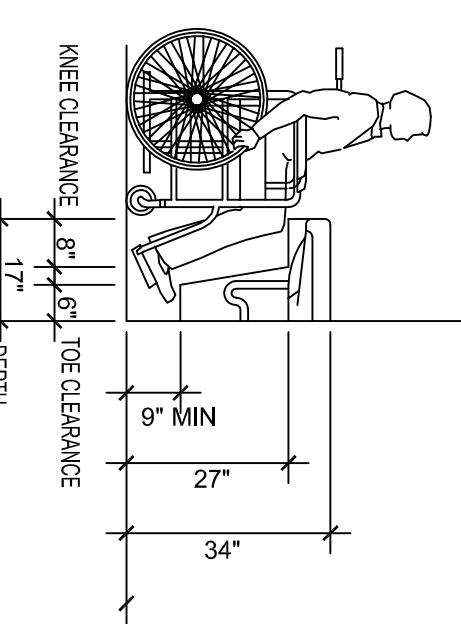

LAVATORY CLEARANCES

WALL NOTES
ALL FRAMING LUMBER SHALL BE NO. 2 SOUTHERN PINE
TYPICAL WALLS SHALL BE 2x4 @ 16" O.C.
BATH WALLS SHALL BE 2x6 @ 16" O.C. UNLESS NOTED.
BLACK WALL STUDS OF 8'-9" TALL IN MID-HEIGHT
FIRE WALLS TO ROOF

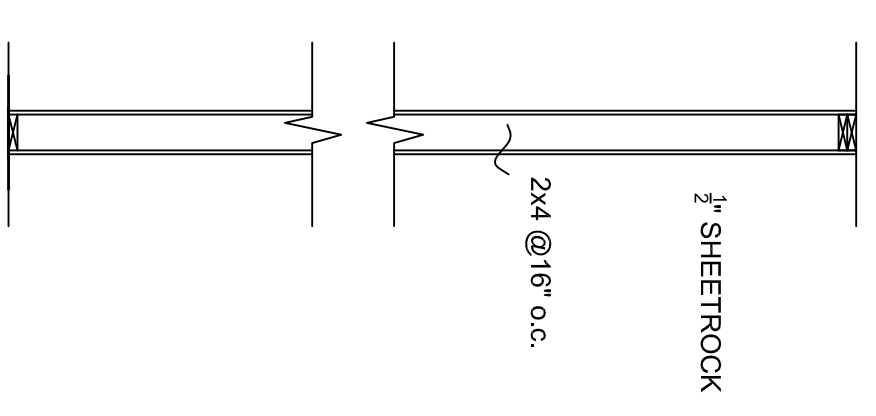

DOOR SCHEDULE			
A	3'-0" x 7'-0"	WOOD	INTERIOR
B	3'-0" x 7'-0"	GLASS	STOREFRONT
		INTERIOR	LEVER LOCK INSIDE ALWAYS
		EXTERIOR	PRIVACY LOCK INSIDE ALWAYS
		OPEN	OPEN

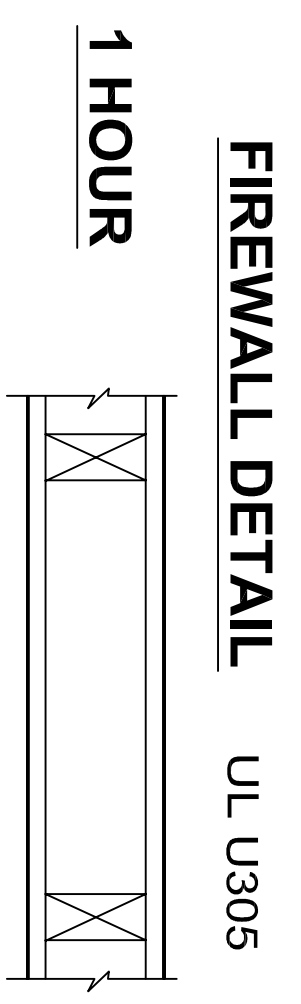

5/8" (15.9mm) Fire-Shield Gypsum Wallboard or 5/8" (15.9mm) Fire-Shield MR Board nailed both sides 2 x 4 (38 mm x 89 mm) wood studs, 16" o.c. (406mm).



1 HOUR FIRE WALL

EXAM CABINET PLAN

SCALE: 1/4" = 1'-0"

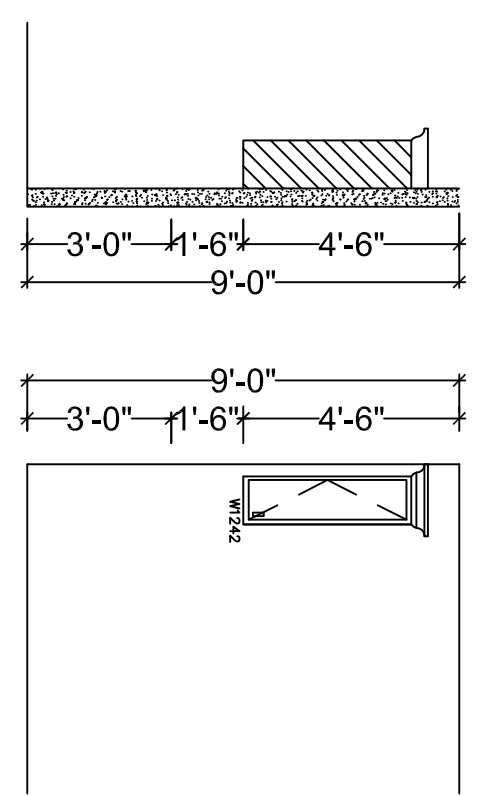

BREAK CABINET PLAN

SCALE: 1/4" = 1'-0"

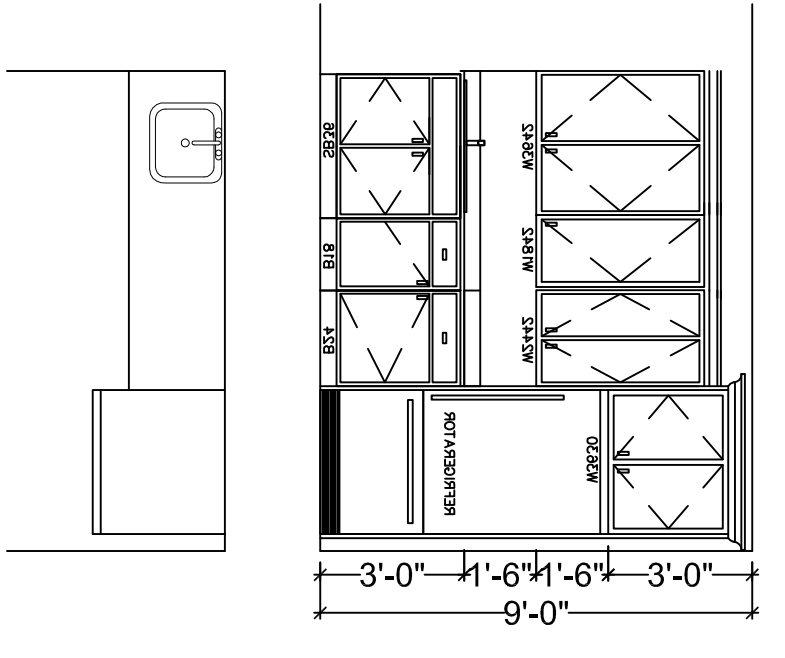

UTILITY CABINET PLAN

SCALE: 1/4" = 1'-0"

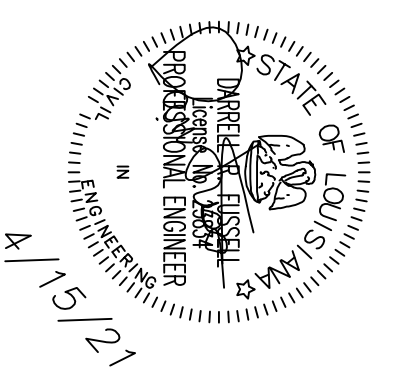
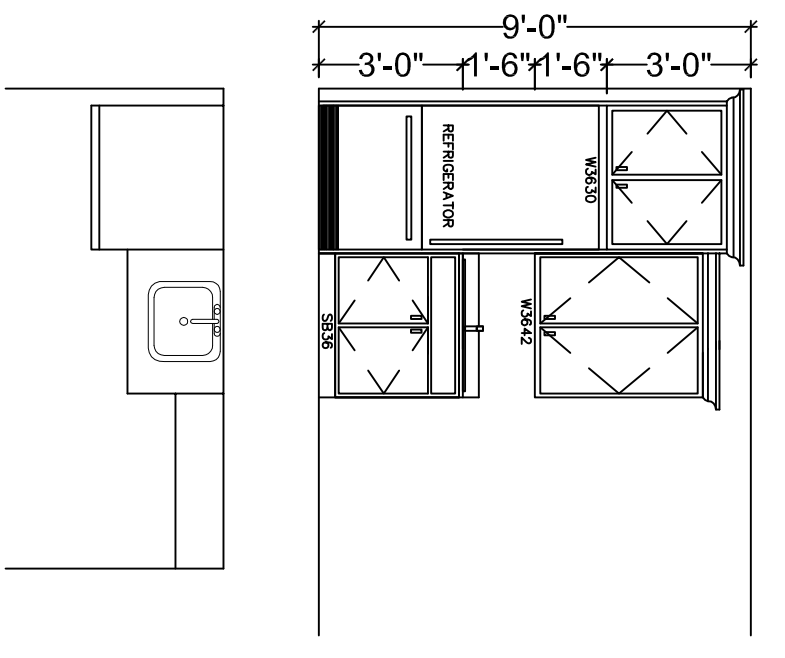

ARROW ENGINEERING & CONSULTING
DARRELL FUSSELL, P.E.
fussell.2@juno.com

PO BOX 881
Madisonville, LA 70447
Phone: 985-237-3908

GREENLIGHT URGENT CARE
1200 BUSINESS 190 SUITE 2A
COVINGTON, LA 70433

Issue	Description	Date
A	For SFM Review	1-26-21
B	Revised	2-9-21
C	added mop sink, sinks, fountain	4-1-21
D	Added lead lined note for x-ray	4-15-21