



SHOPPES OF MEADOWBROOK

2001-2153 W 63rd St, Downers Grove, IL
ANCHOR SPACE, INLINE RETAIL & OUTLOTS AVAILABLE FOR LEASE



CONTACT
INFORMATION:

STEVE BAER
SBAER@METROCRE.COM
847.412.9898

JONATHAN HYMAN
JHYMAN@METROCRE.COM
224.365.8144



COMPLETE REDEVELOPMENT



REDEVELOPMENT DETAILS

- New Façade Renovation - Completed Q4 '25.
- New Roof - Full roof replacement completed in 2024.
- New Parking Fields - All new asphalt parking fields and striping.
- Landscaping - beautiful new landscaping for a pleasant shopping experience
- New Lighting - Full LED conversion - New lighting fixtures
- New Monument Signage - Located at both 63rd & Woodward entrances

WHAT'S NEW...

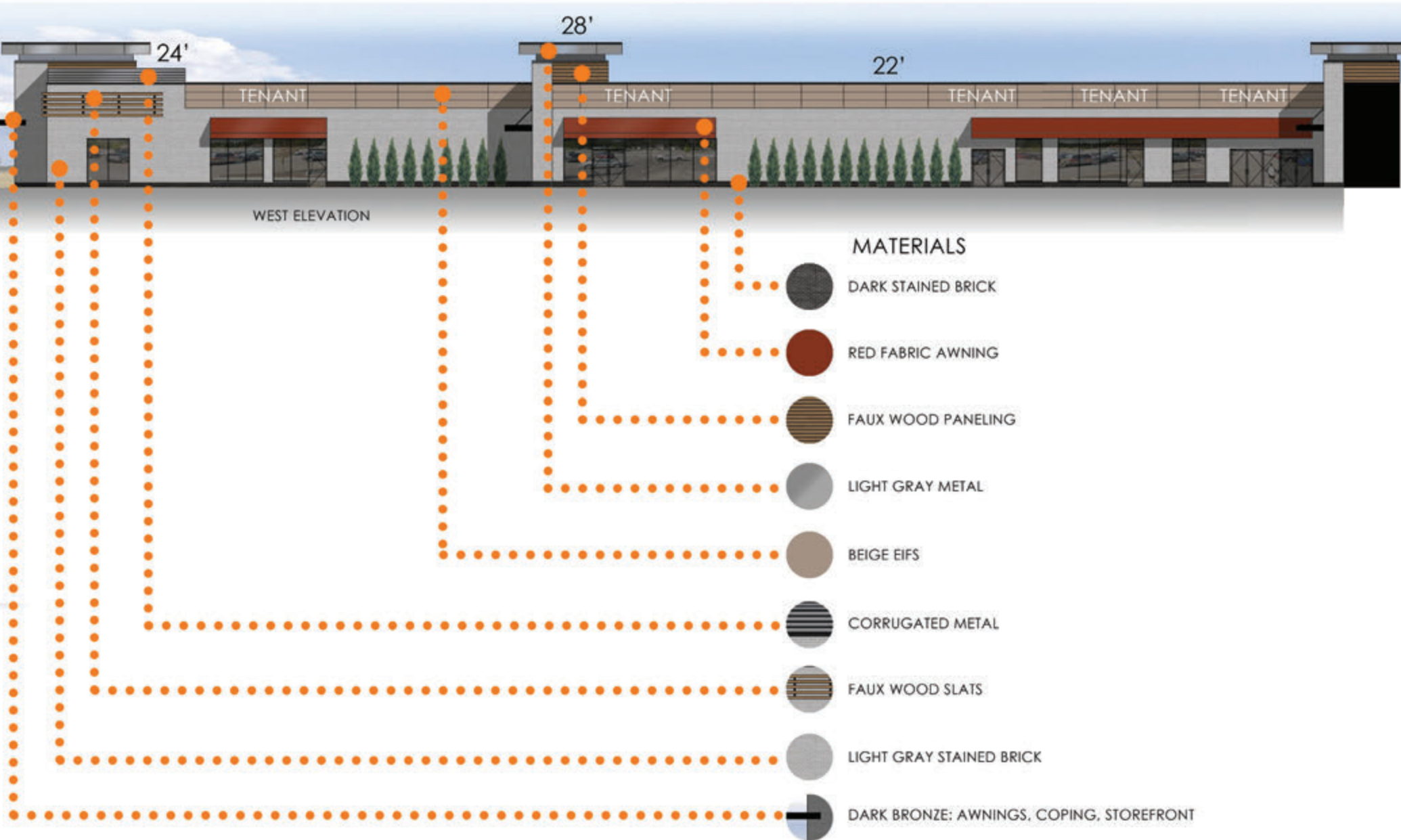

GLIMPSE INTO WHAT'S TO COME



CLICK **HERE** TO VIEW
NEW OUTLOTS

CLICK **HERE** TO VIEW
NEW MONUMENT SIGNAGE

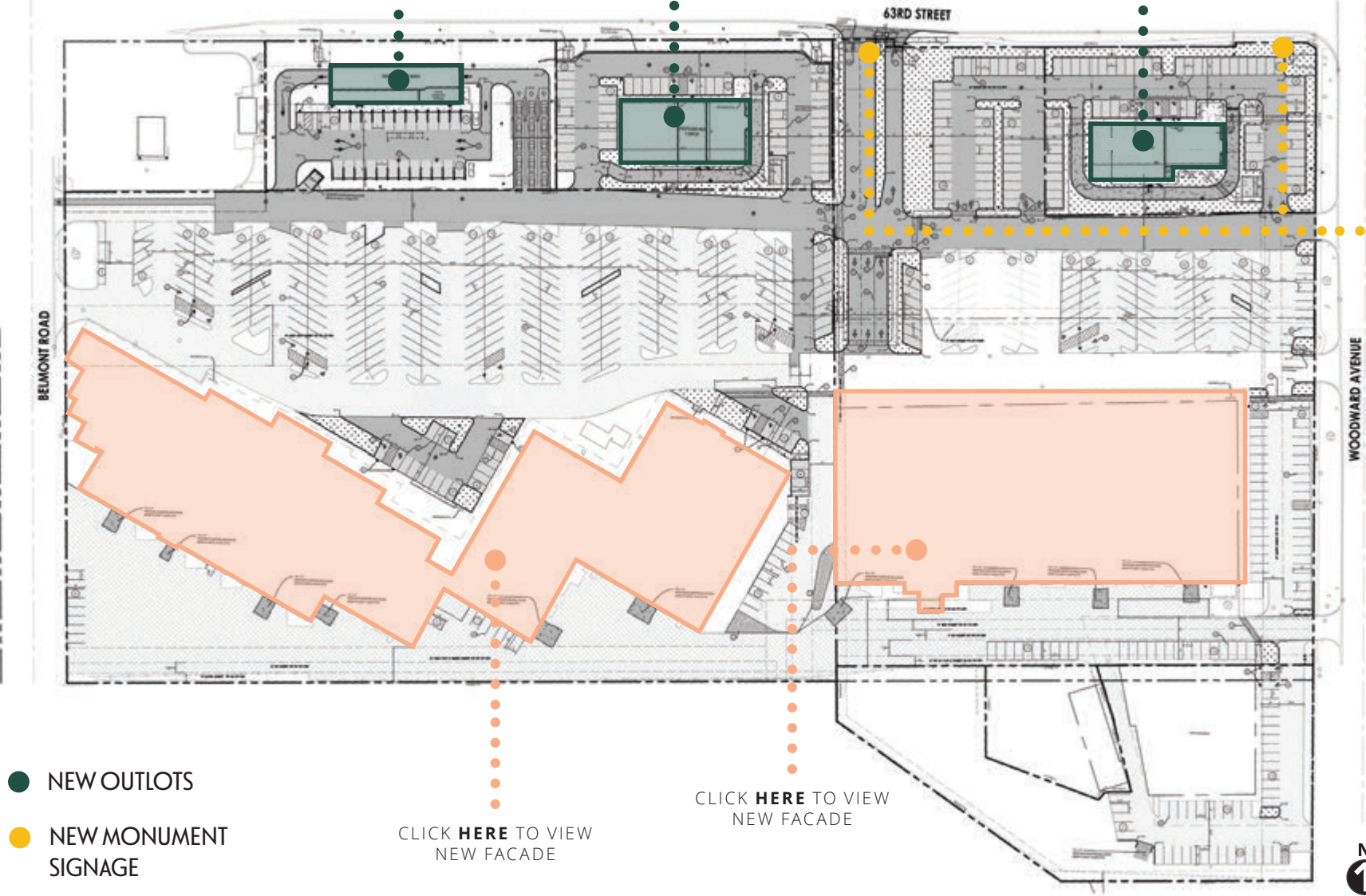

● NEW OUTLOTS

● NEW MONUMENT SIGNAGE

● NEW FACADE

CLICK **HERE** TO VIEW
NEW FACADE

CLICK **HERE** TO VIEW
NEW FACADE



GLA = 188,497 SF
PARKING = 850 STALLS

LOCATION AERIAL

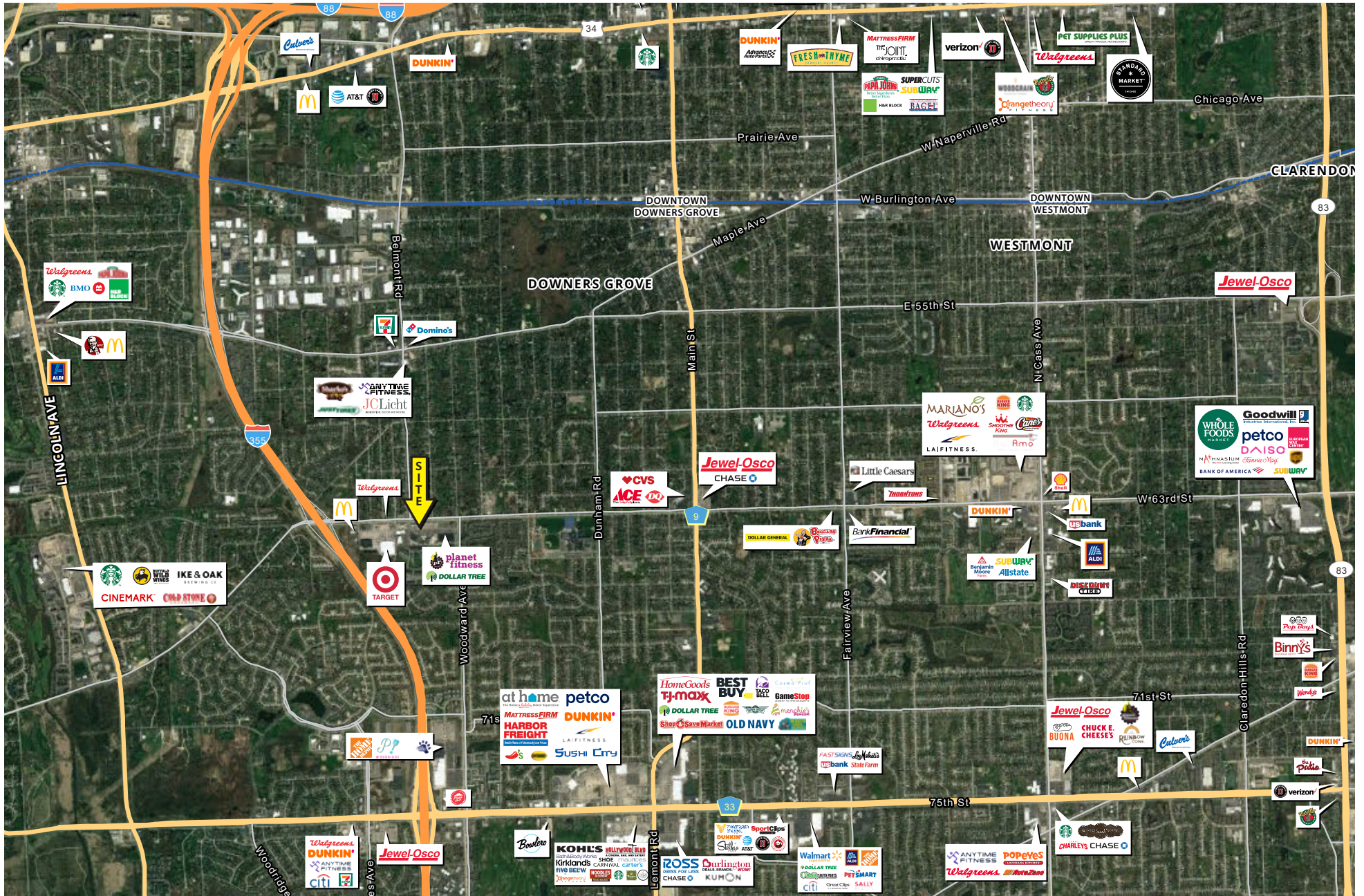

2001-2153 W 63rd St, Downers Grove, IL
FOR LEASE

GET TO KNOW THE AREA

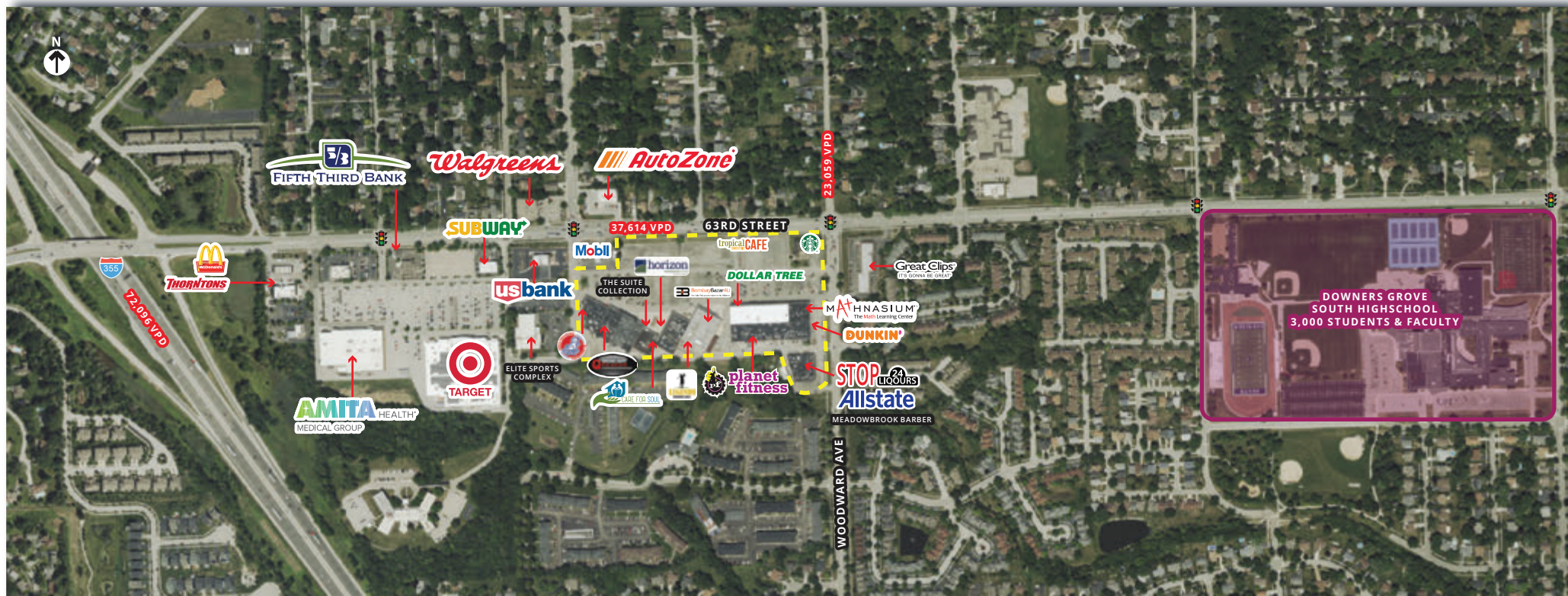

TOTAL POPULATION

1 MI 14,020
3 MI 105,917
5 MI 252,436



HOUSE HOLDS

1 MI 5,592
3 MI 43,833
5 MI 100,010



DAYTIME POPULATION

1 MI 8,058
3 MI 77,750
5 MI 223,246



AVG HH INCOME

1 MI \$117,005
3 MI \$123,936
5 MI \$134,123

TRAFFIC COUNTS

63RD ST	37,614 VPD
I-355	72,096 VPD
WOODWARD AVE	23,059 VPD

AREA TENANTS INCLUDE



OUTLOT TENANTS



Pylon A
Single Tenant
Monument Sign Opportunity

Pylon B

Pylon D

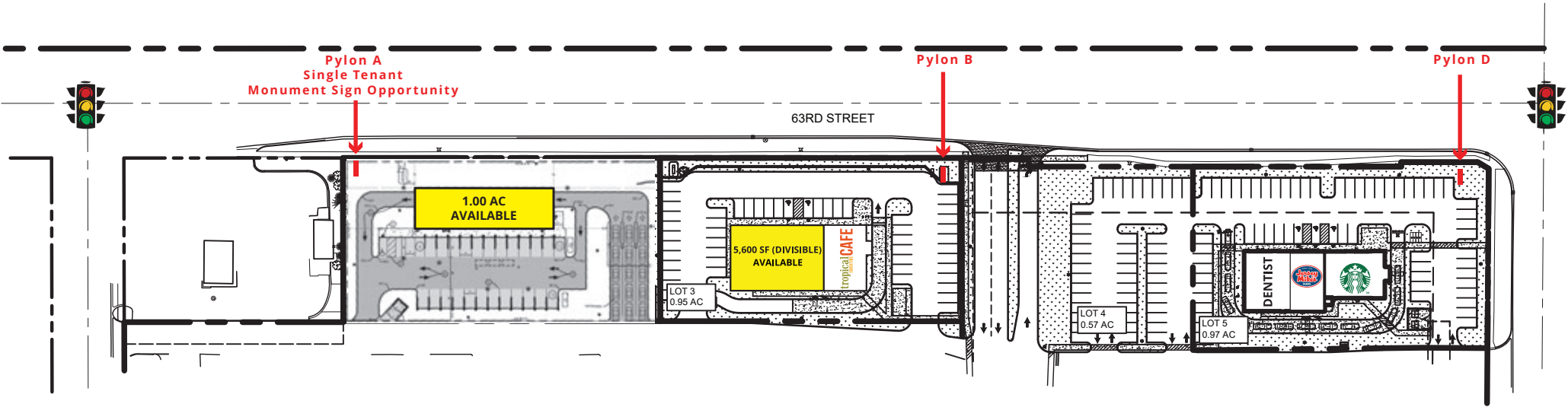

PYLON A

PYLON B

PYLON D

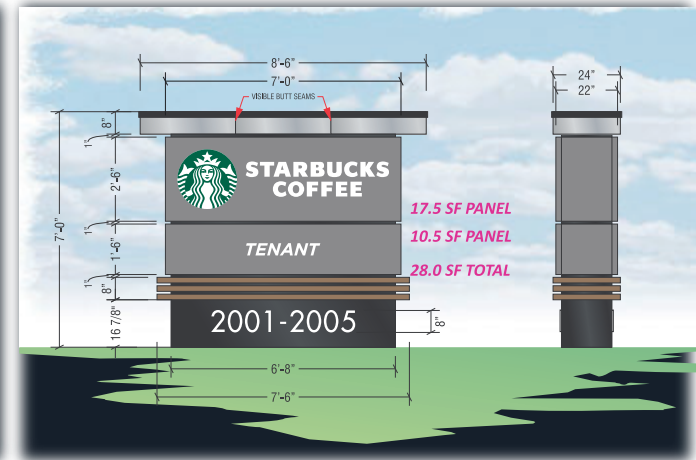
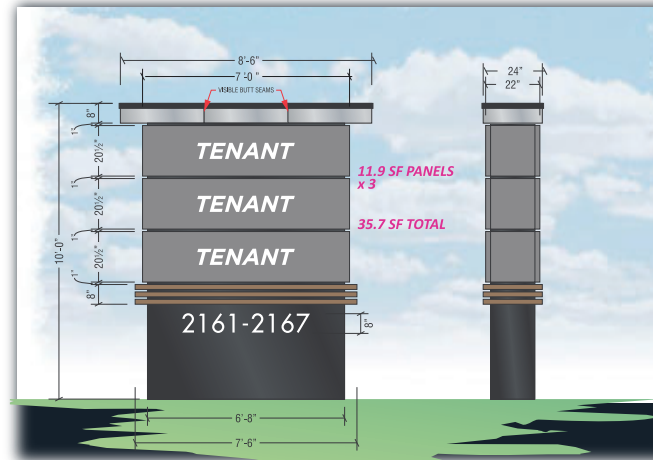
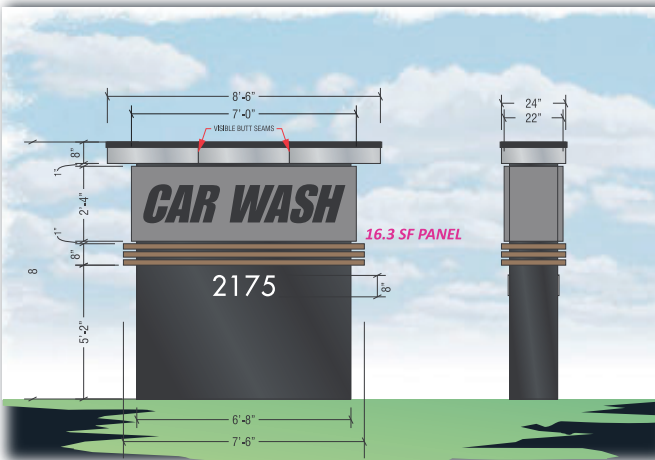

OUTLOT RETAILERS & TRAFFIC GENERATORS:





LEASING CONTACTS



STEVE BAER

SBAER@METROCRE.COM

847.412.9898

JONATHAN HYMAN

JHYMAN@METROCRE.COM

224.365.8144



WWW.METROCRE.COM

© 2026 METRO COMMERCIAL REAL ESTATE. ALL RIGHTS RESERVED. ALL INFORMATION CONTAINED HEREIN IS FROM SOURCES DEEMED RELIABLE; HOWEVER, NO REPRESENTATION OR WARRANTY IS MADE TO THE ACCURACY THEREOF.