

THE WORKPLACE REIMAGINED

2655 NORTHWESTERN HWY
SOUTHFIELD, MI 48033

*World Class
HQ and Tech Center*

LONG TERM SUBLEASE
MOVE-IN READY CAMPUS
200,000 SF AVAILABLE

Unrivaled Quality...

Unique Opportunity...

2655 Northwestern Hwy is an exceptional workplace campus defined by unmatched quality and market-leading spaces. Purpose-built as a hub for collaborative workforce, this full-campus lease opportunity offers large users a highly amenitized, high-quality office and automotive labs in a strategically connected location.

HIGHLIGHTS

- 200,000 SF office and lab space for lease
- Currently has seats for 543
- Lab ceiling heights 12-26'
- Fully furnished with brand new, modern furnishings
- Outdoor balcony for dining
- Great parking with some executive garage spaces

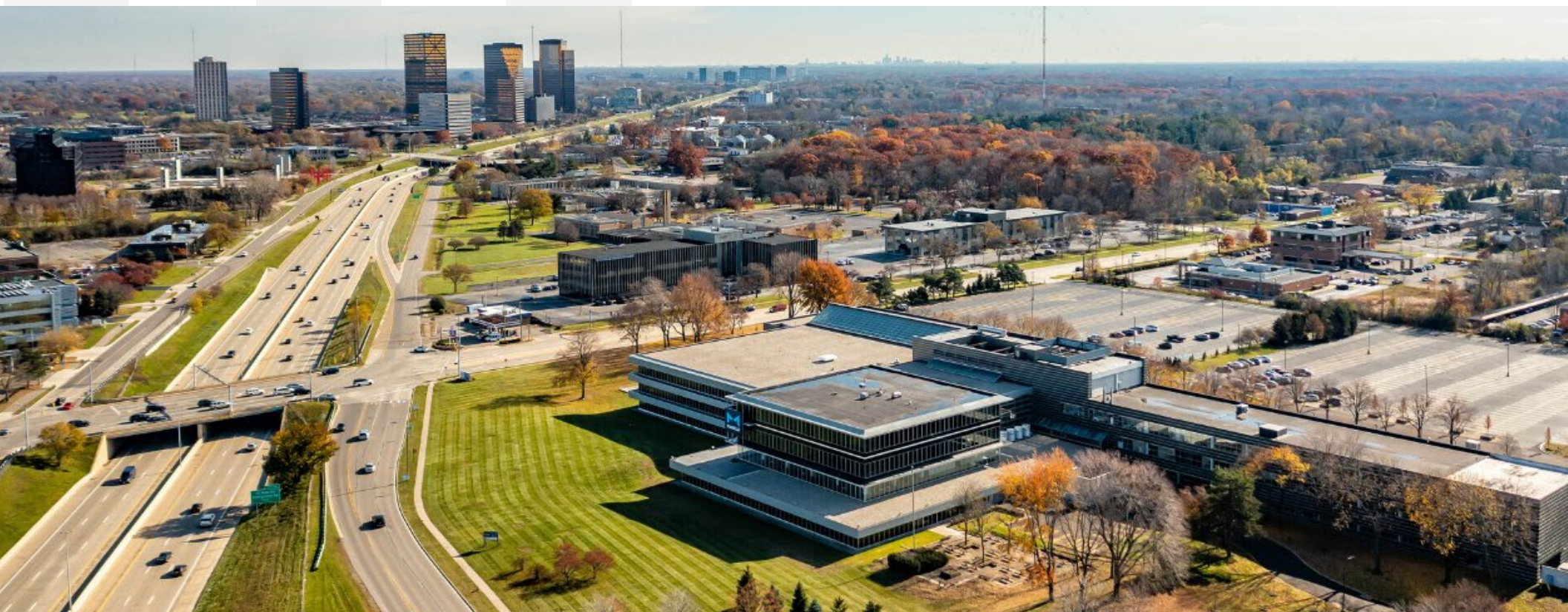

Best in Class Features...

By offering the workday experience employees want, gives businesses a competitive advantage. Lifestyle, competition, and convenience converge here with best-in-class features.



Vision Labs



Common Areas



Atlas Air Compressor

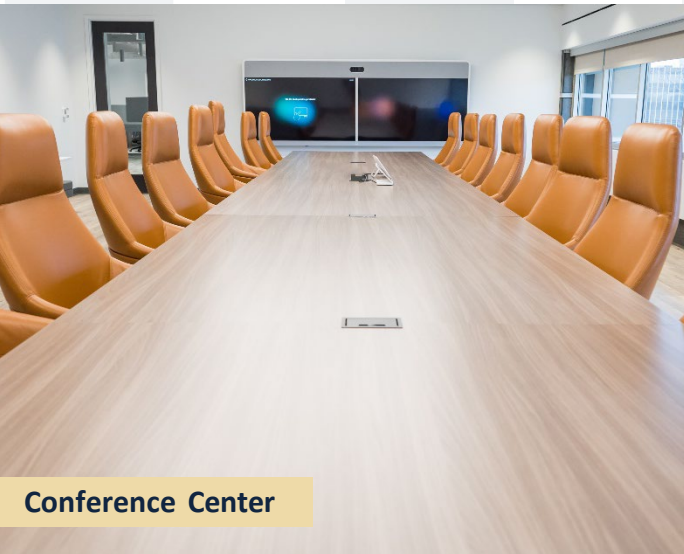

Conference Center



Auditorium



BAC Water Tower

Explore The Space...

Building Features

Address	26555 Northwestern Hwy, Southfield, MI
Building Class	B
Year Built/ Renovated	1967/ 2018
Seat Count	Cubes 481, Offices 62, Conference/ Huddle/ Phone/ Auditorium 83
Auto Parking	926 Spaces
Ground Level Doors	5 Total
Power	9,700a/13,200v
Fire Protection	Wet System (Sprinkler Heads & Fire Pump)
Cooling Tower	Boston Aircoil Company (BAC) Model s15E-1212-09LN
Zoning	ERO: Education Research Office
Building Construction Type	Steel
Roof System	Rubber w/10 A Stone
HVAC	Mix Of Hot Water Boiler And Forced Air
Natural Gas/ Electricity	Consumers Energy/ DTE
Sewer/Water	City of Southfield

Square Footage

Total Building	200,000 SF
Office Area	110,000 SF
Lab Area	88,176 SF
Basement	1,471 SF
Land Area (Acres)	19.5 AC (Plenty Of Room For Expansion Onsite)
Parcel(s) ID	24-21-202-027, 24-21-202-031

Pricing

Sublease Term	Long Term (Negotiable)
Sublease Rate	Contact Broker



Enjoy the Best of Southfield...

This location offers outstanding access, and excellent visibility- and is just 20 minutes from dynamic, bustling downtown Detroit and its exciting array of entertainment, retail, dining, and cultural amenities.

LOCATION BENEFITS



- Easily accessible from I-696 and M-10
- Signage & branding opportunities
- Long-term sublease
- 20 minutes from Downtown Detroit
- Excellent retail & dining within a 10-minute drive
- Southfield is considered the center of Metro Detroit
- Neutral to the “Big Three” (Ford, GM, Stellantis)



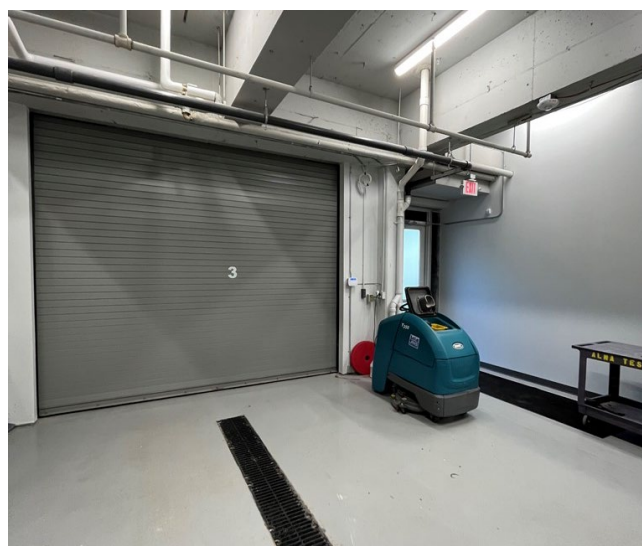
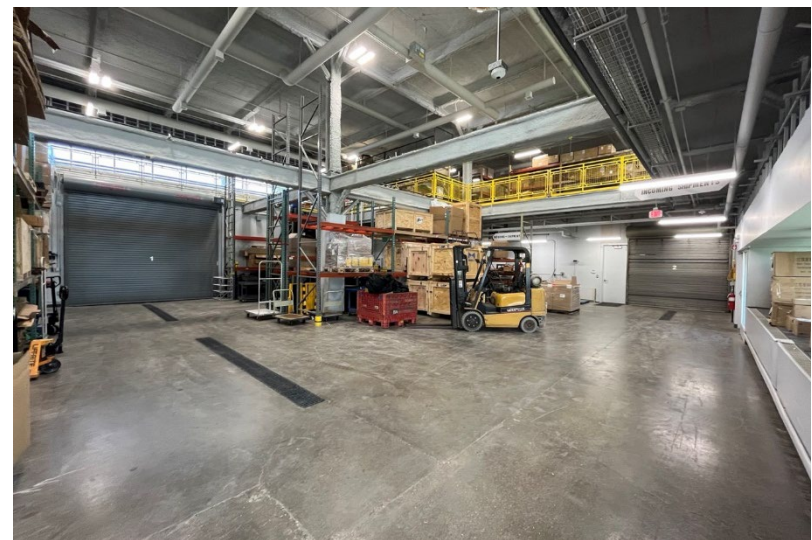

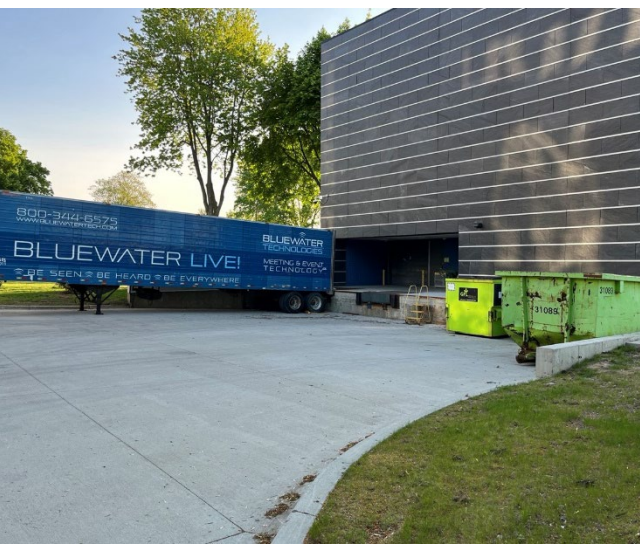
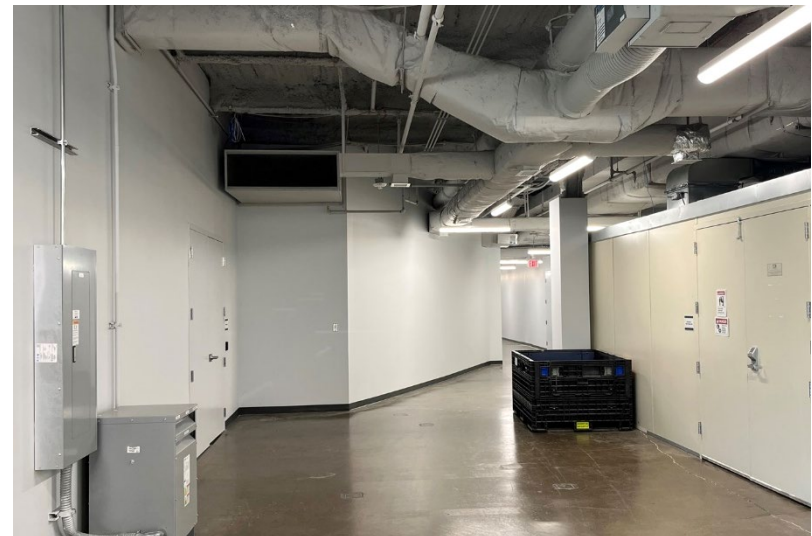

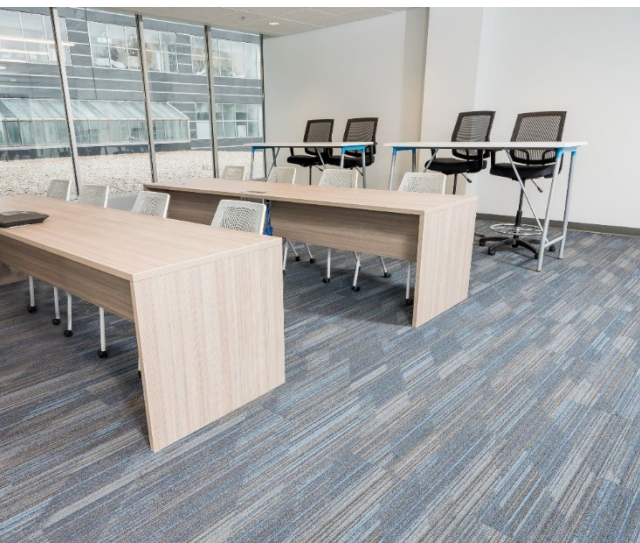

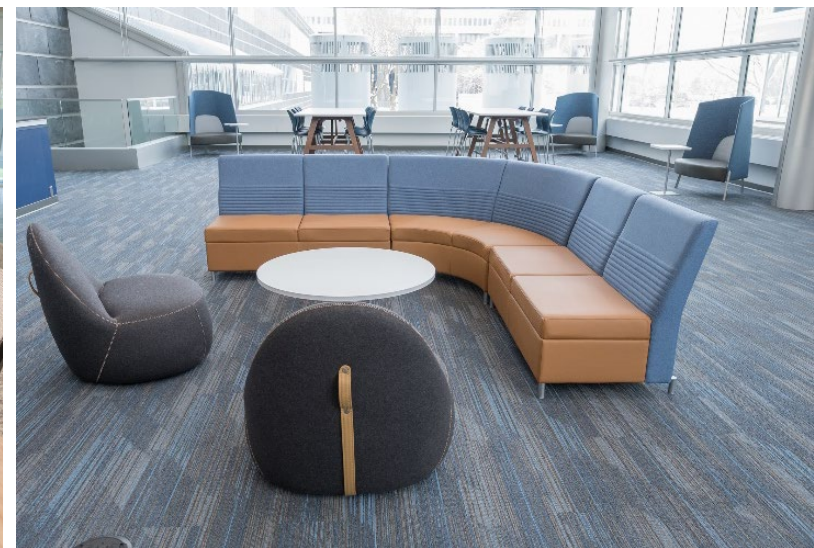
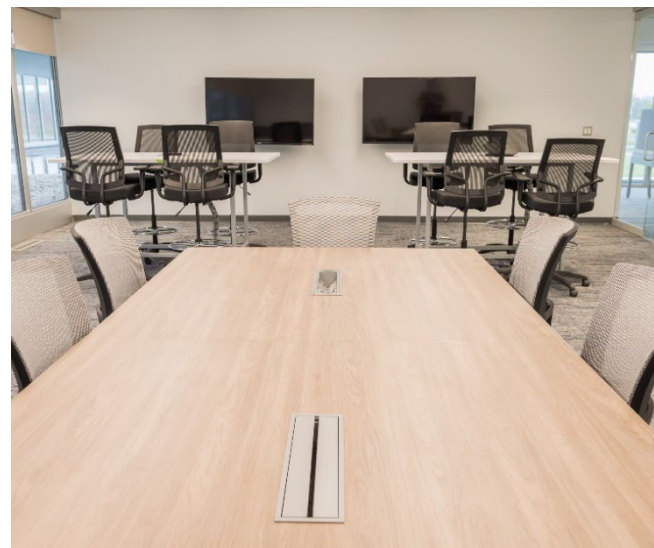

Floor Plans

Full 1st Floor (Lab & Office)

1st FLOOR: 86,112 SF

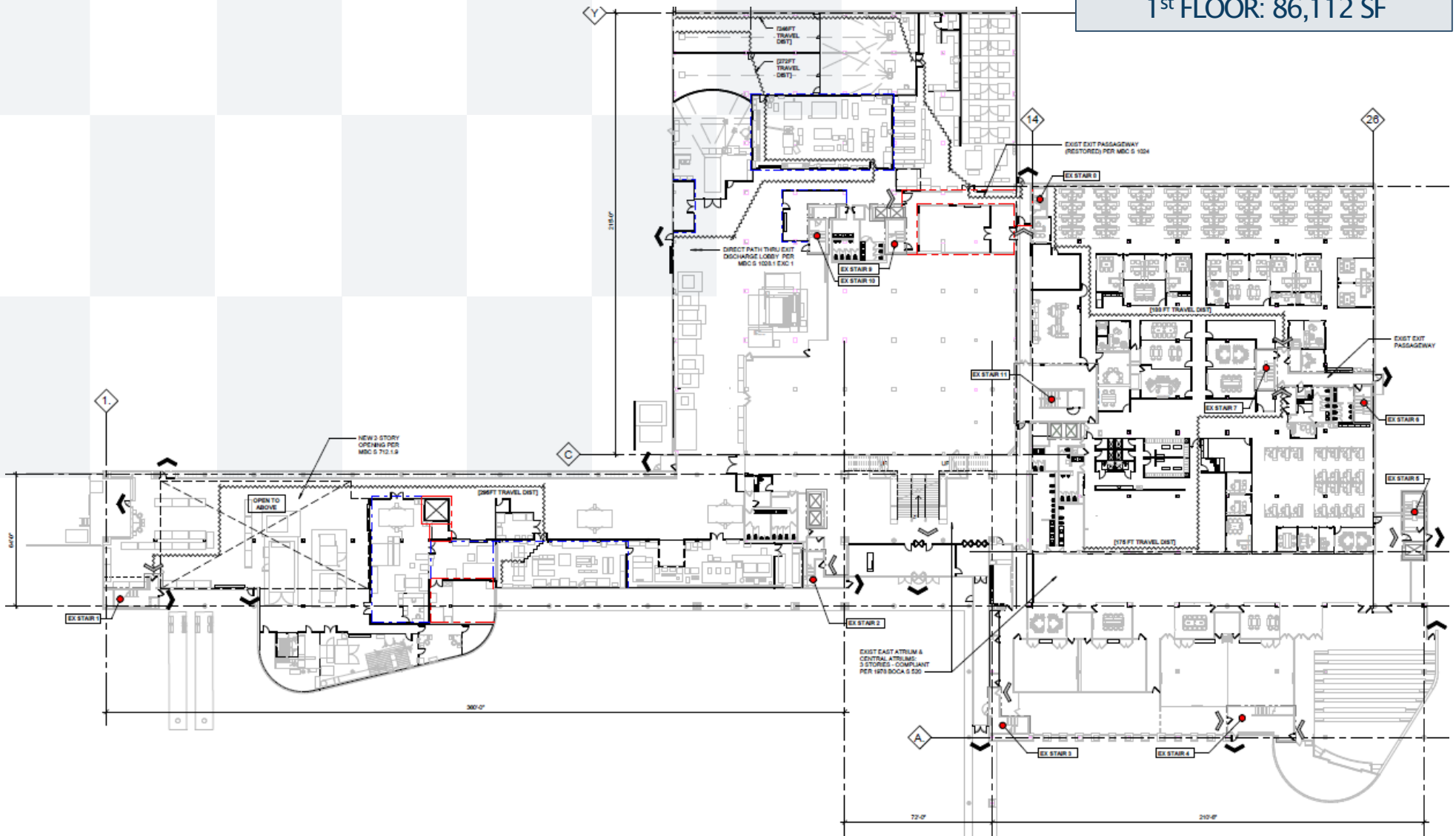

Floor Plans

Full 2nd Floor (Lab & Office)

2nd FLOOR: 53,851 SF

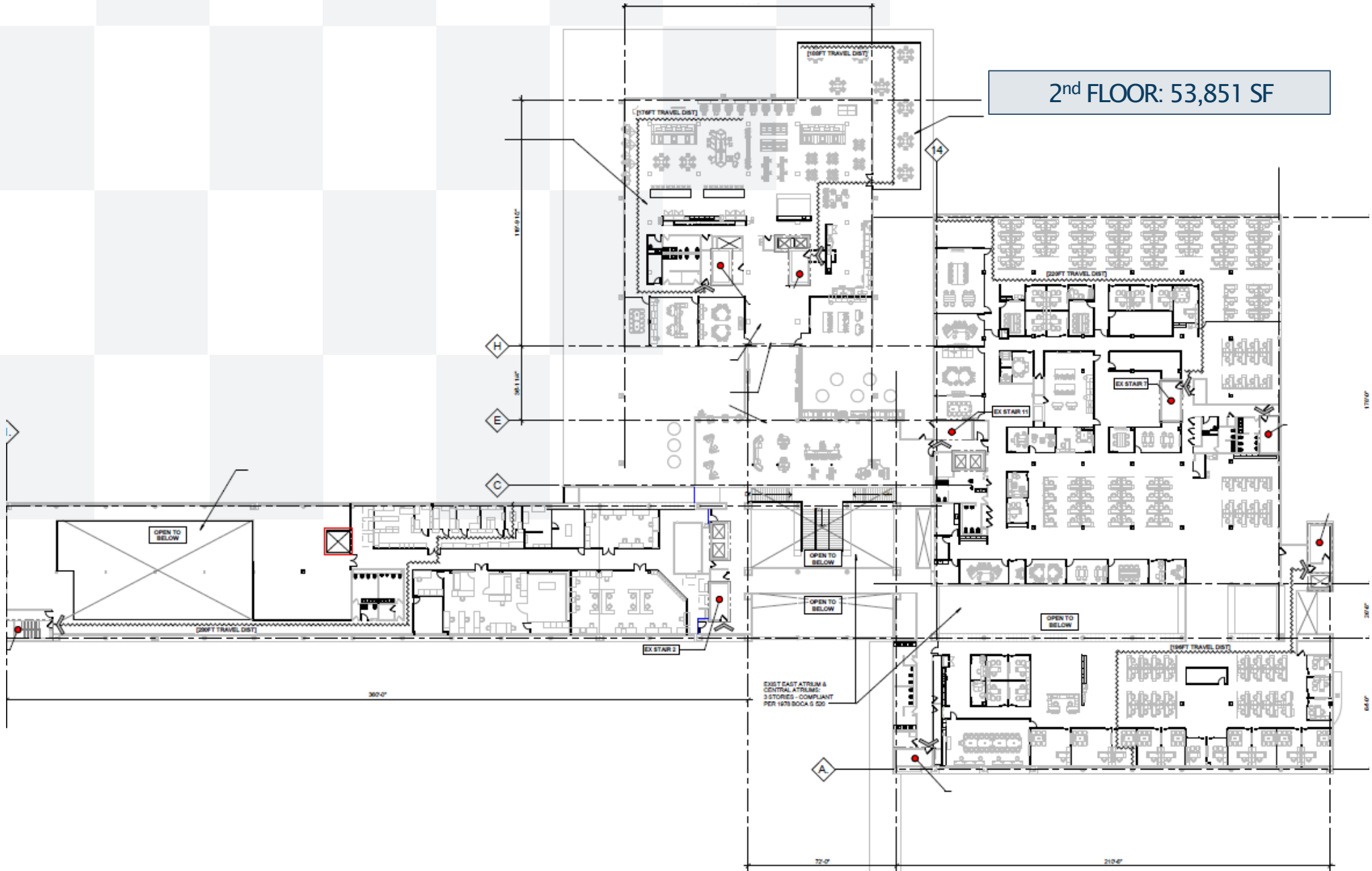

Floor Plans

Full 3rd Floor (Lab & Office)

3rd FLOOR: 15,319 SF Available

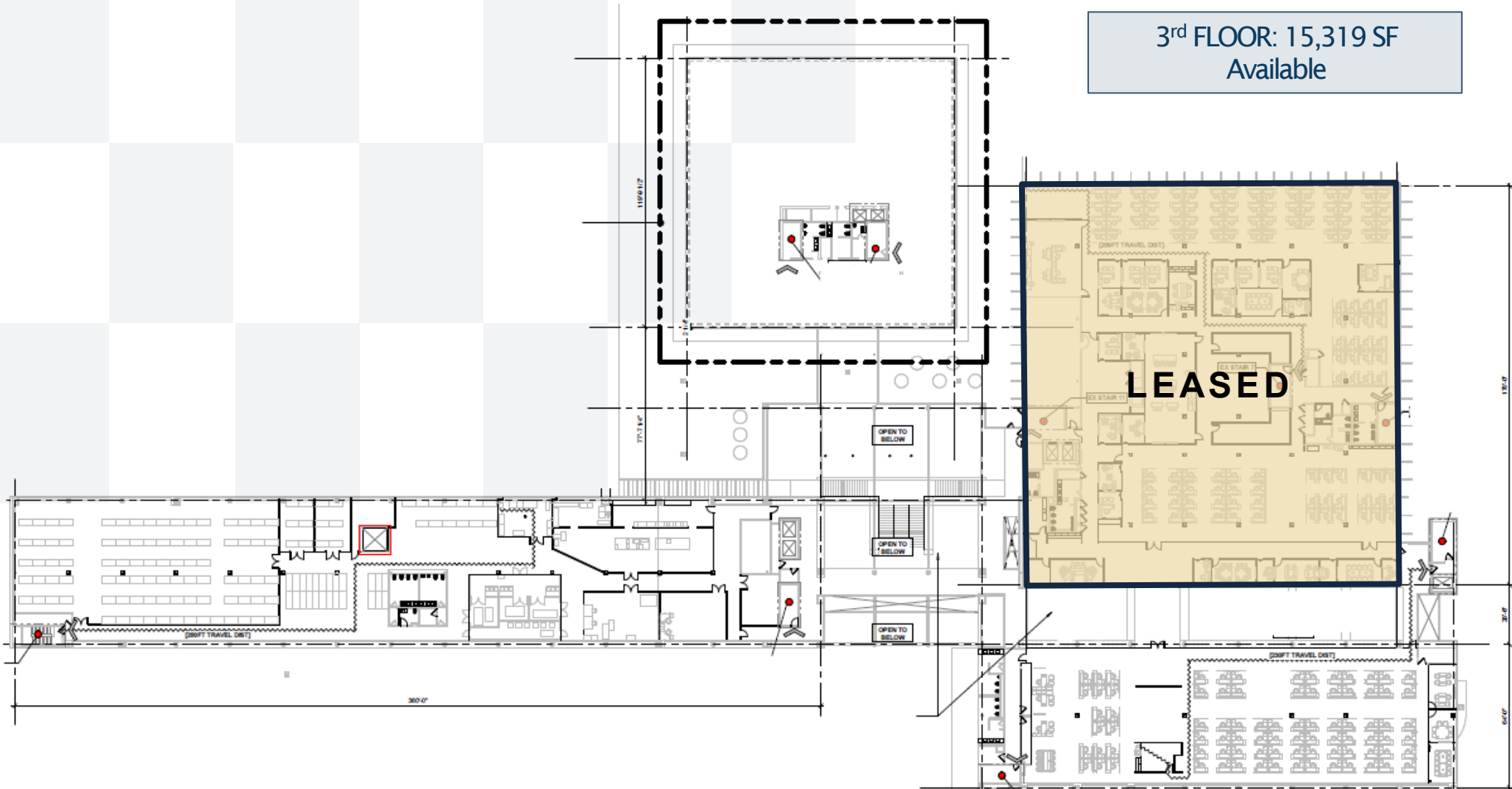

Floor Plans

Basement

TOTAL SF: 1,471 SF



Floor Plans

Office – 1st Floor

AREA A

AREA A

Workstations Total: 68

Private Offices: 6 Standard, 6 Executive













AREA B

Workstations Total: 22

Private Offices: 2 Standard, 1 Executive

TOTAL SF: 36,666

KEY

EXECUTIVE OFFICE	7	
STANDARD OFFICE	8	
WORKSTATIONS	90	
EXTRA LARGE CONFERENCE (22+)	1	
LARGE CONFERENCE (18-22)	4	
MEDIUM CONFERENCE (8-16)	12	
SMALL HUDDLE (3-6)	8	
PHONE ROOM (1-3)	7	
EXTRA LARGE OPEN COLLABORATION (20+)	0	
LARGE OPEN COLLABORATION (12-18)	1	
MEDIUM OPEN COLLABORATION (4-10)	4	
SMALL OPEN COLLABORATION (1-3)	0	



Floor Plans

Office – 2nd Floor

AREA C

Workstations Total: 121

Private Offices: 8 Standard, 2 Executive















AREA D

Workstations Total: 30 + 4 Admin

Private Offices: 9 Standard, 9 Executive

TOTAL SF: 36,667

KEY

EXECUTIVE OFFICE	11	
STANDARD OFFICE	17	
TOTAL WORKSTATIONS	155	
EXTRA LARGE CONFERENCE (22+)	4	
LARGE CONFERENCE (16-22)	2	
MEDIUM CONFERENCE (8-16)	10	
SMALL HUDDLE (3-6)	6	
PHONE ROOM (1-3)	7	
EXTRA LARGE OPEN COLLABORATION (20+)	1	
LARGE OPEN COLLABORATION (12-18)	1	
MEDIUM OPEN COLLABORATION (4-10)	9	
SMALL OPEN COLLABORATION (1-3)	1	
BOARD ROOM	1	
CAFE	1	
MEZZANINE	1	

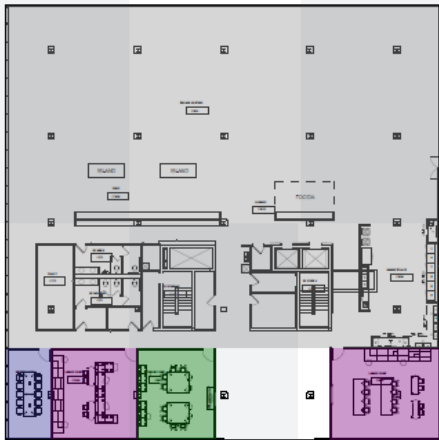

AREA C



AREA D

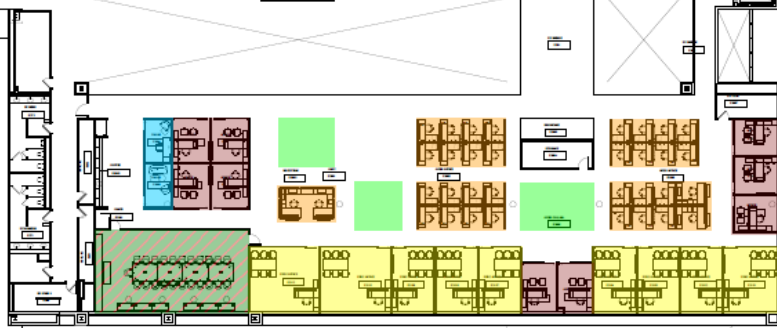

Floor Plans

Office – 3rd Floor













AREA E

Workstations Total: 208

Private Offices: 11 Standard, 1 Executive

AVAILABLE SF: 15,319

KEY

EXECUTIVE OFFICE	1	
STANDARD OFFICE	11	
WORKSTATIONS	206	
EXTRA LARGE CONFERENCE (22+)	2	
LARGE CONFERENCE (18-22)	0	
MEDIUM CONFERENCE (8-16)	9	
SMALL HUDDLE (3-6)	10	
PHONE ROOM (1-3)	4	
EXTRA LARGE OPEN COLLABORATION (20+)	2	
LARGE OPEN COLLABORATION (12-18)	1	
MEDIUM OPEN COLLABORATION (4-10)	8	
SMALL OPEN COLLABORATION (1-3)	1	



AREA E

Floor Plans

Lab - 1st Floor & North Area

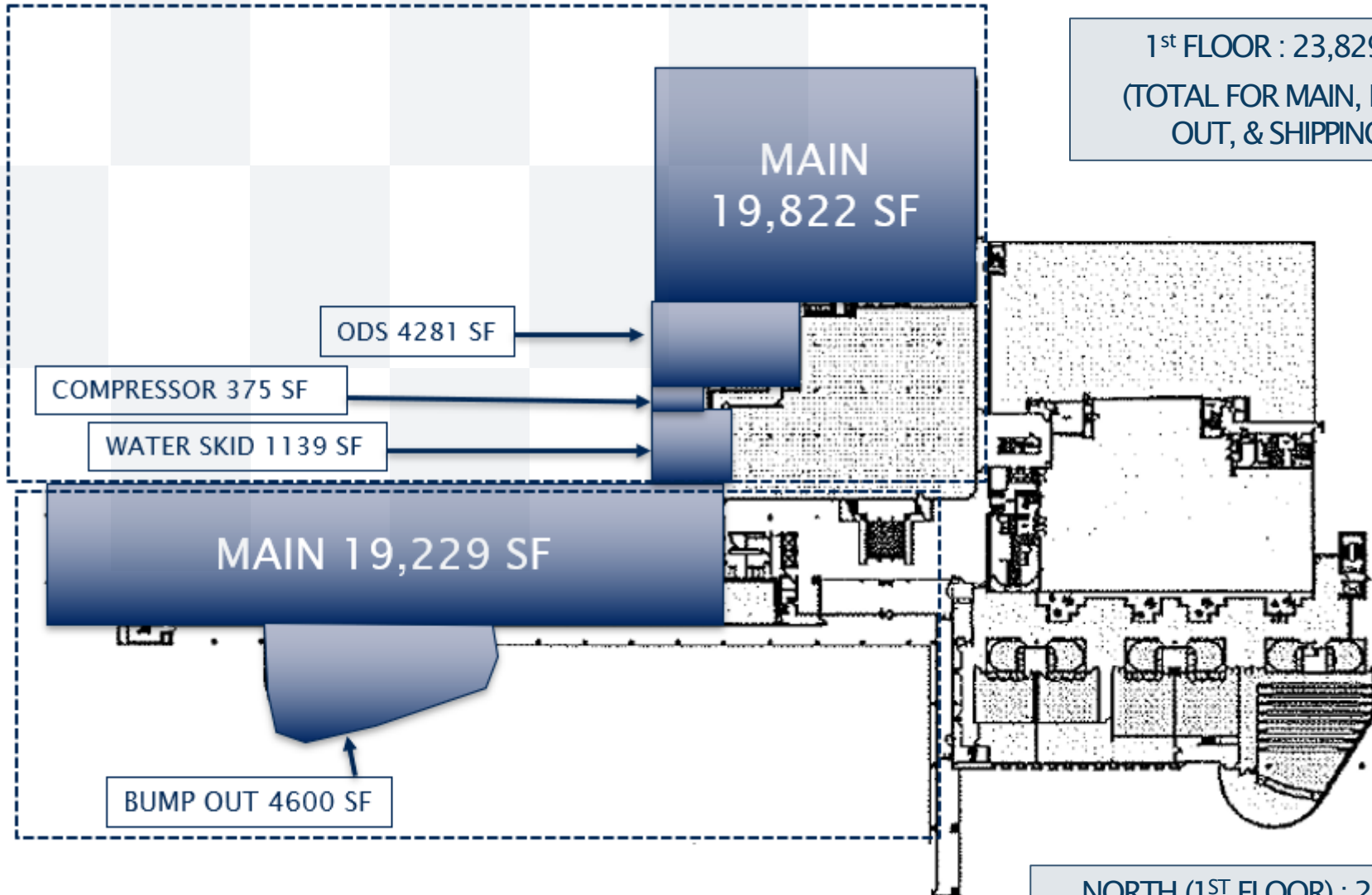

1st FLOOR : 23,829 SF
(TOTAL FOR MAIN, BUMP
OUT, & SHIPPING)

NORTH (1ST FLOOR) : 25,617 SF
(TOTAL FOR MAIN, ODS,
COMPRESSOR, & PUMP)

Floor Plans

Lab - 2ND Floor

2ND FLOOR: 17,185 SF
(TOTAL FOR MAIN MINUS
HIGH BAY CUT OUT)

HIGH BAY CUT OUT 4362 SF

MAIN 21,546 SF

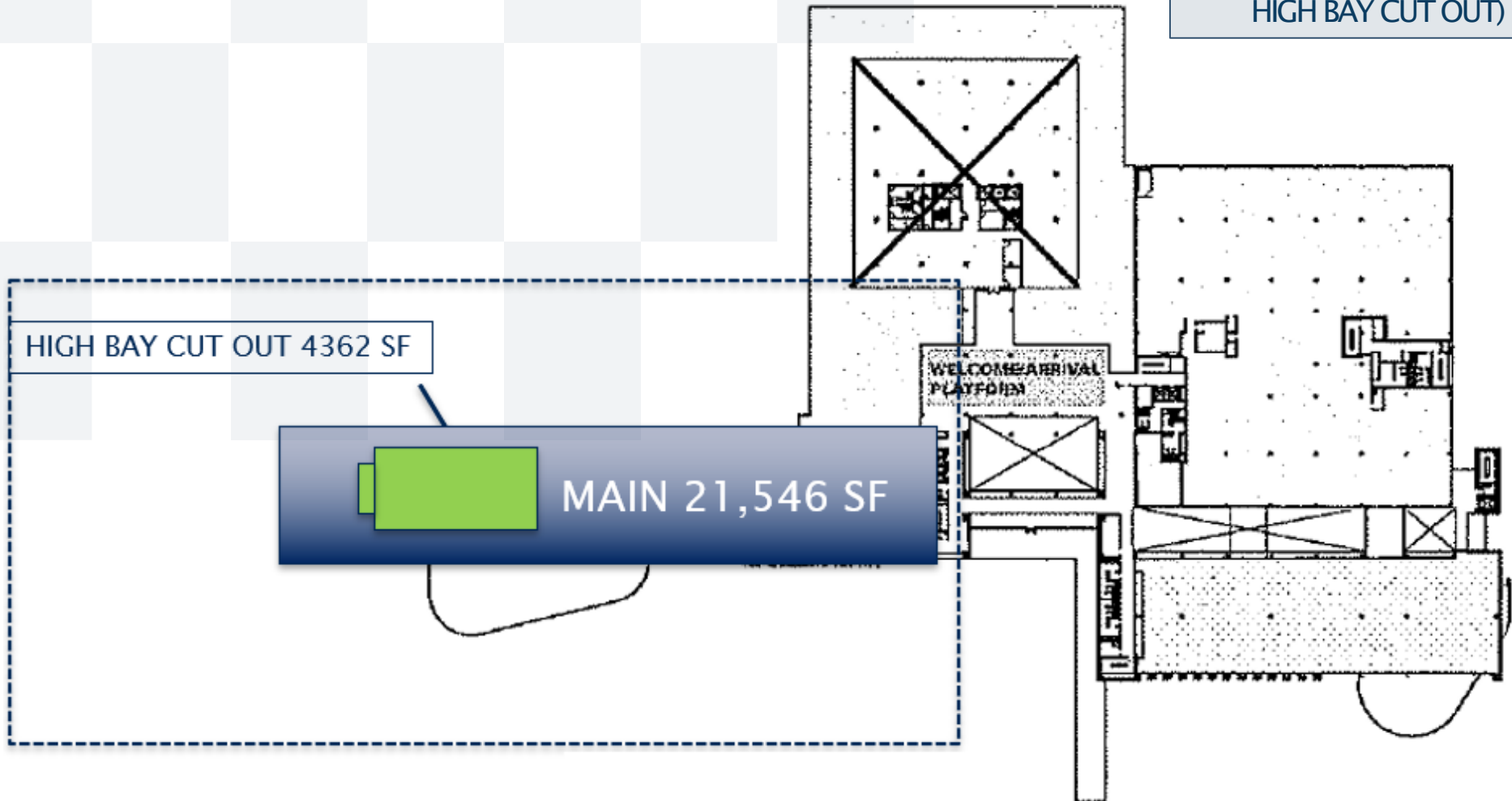

Floor Plans

Lab - 3RD Floor

3RD FLOOR: 21,546 SF

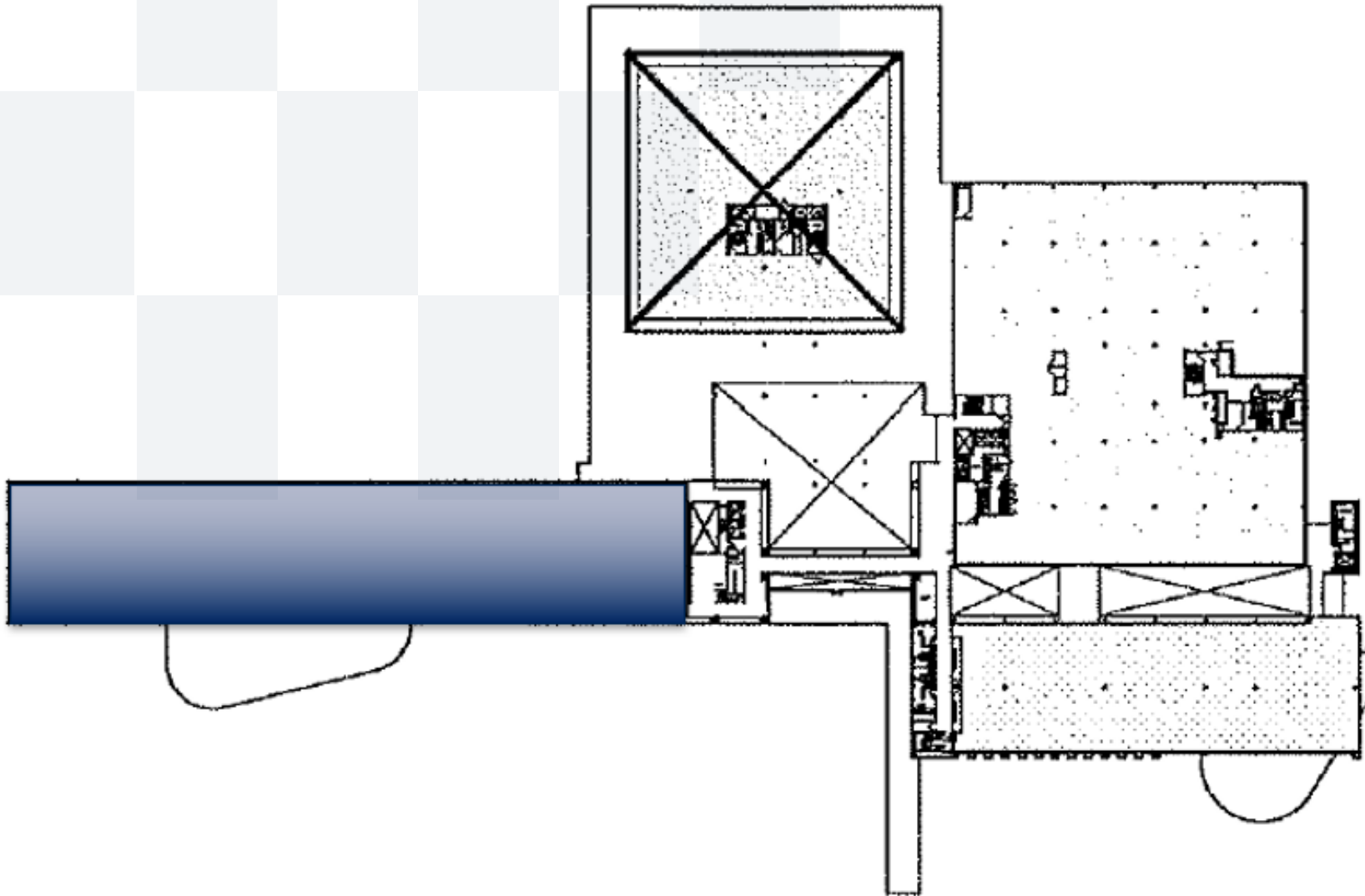

Site Plan

MARELLI, NORTH AMERICA 26555 NORTHWESTERN HIGHWAY CITY OF SOUTHFIELD, OAKLAND COUNTY, MICHIGAN SITE PLAN

SHEET INDEX:

0.1	SITE PLAN
0.2	EXISTING CONDITIONS & DEVELOPMENT PLAN
0.3	PRELIMINARY ENGINEERING PLAN
0.4	DETAIL SHEET
0.5	DETAIL SHEET
1.0	LANDSCAPE PLANS (PREPARED BY ALLEN DESIGN)
1.1	LANDSCAPE PLAN
1.2	WOODLAND PLAN
1.3	TREE LIST
1.4	LANDSCAPE DETAILS

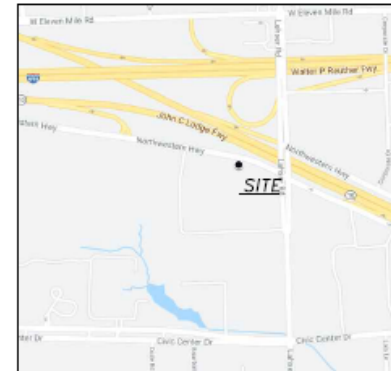

APPLICANT/DEVELOPER:
DEMBIS DEVELOPMENT, INC.
27700 STANBROOK, SUITE 200
FARMINGTON HILLS, MI 48334
PHONE: (248) 380-7100
CONTACT: GLENN JONES

SITE DATA:
ADDRESS: 26555 NORTHWESTERN HWY.,
SOUTHFIELD, MI 48033

MAP REFERENCE:
SDEALL #24-21-202-027, 24-21-202-030, 24-21-202-031

ZONING: ERO (EDUCATION RESEARCH-OFFICE)

OVERALL DEVELOPMENT AREA: 422.44 ACRES

BUILDING AREA: 2334,000 GROSS SQ. FT.

BUILDING SETBACK DIMENSIONS:

	BUILDING	MIN. REARLINE	CL. MIN. PROMISE
FRONT (NORTH/EAST)	75'	154.75'	
REAR (WEST)	30'	102'	
LEFT (SOUTH)	75'	454'	

COMMERCIAL
SURVEYING
ALLEN DESIGN
10000 WOODLAND DR
TROY, MI 48063
TEL: (248) 380-7100
WWW.ALLEN-DESIGN.COM

RESIDENTIAL
DEMBIS DEVELOPMENT, INC.
27700 STANBROOK
FARMINGTON HILLS, MI 48334
TEL: (248) 380-7100
WWW.DEMBIS-DEVELOPMENT.COM

ALPINE ENGINEERING, INC.
10000 WOODLAND DR
TROY, MI 48063
TEL: (248) 380-7100
WWW.ALPINE-ENGINEERING.COM

811
Know what's below
Call before you dig.

CLIENT: DEMBIS DEVELOPMENT, INC.

PROJECT: MARELLI, NORTH AMERICA

DATE: 2022-09-12

DRAWN BY: TO

CHECKED BY: SD/TO

SCALE: AS SHOWN

PROJECT NO.: 26555 NW HWY

DATE: 2022-09-12

DRAWN BY: TO

CHECKED BY: SD/TO

SCALE: AS SHOWN

PROJECT NO.: 26555 NW HWY

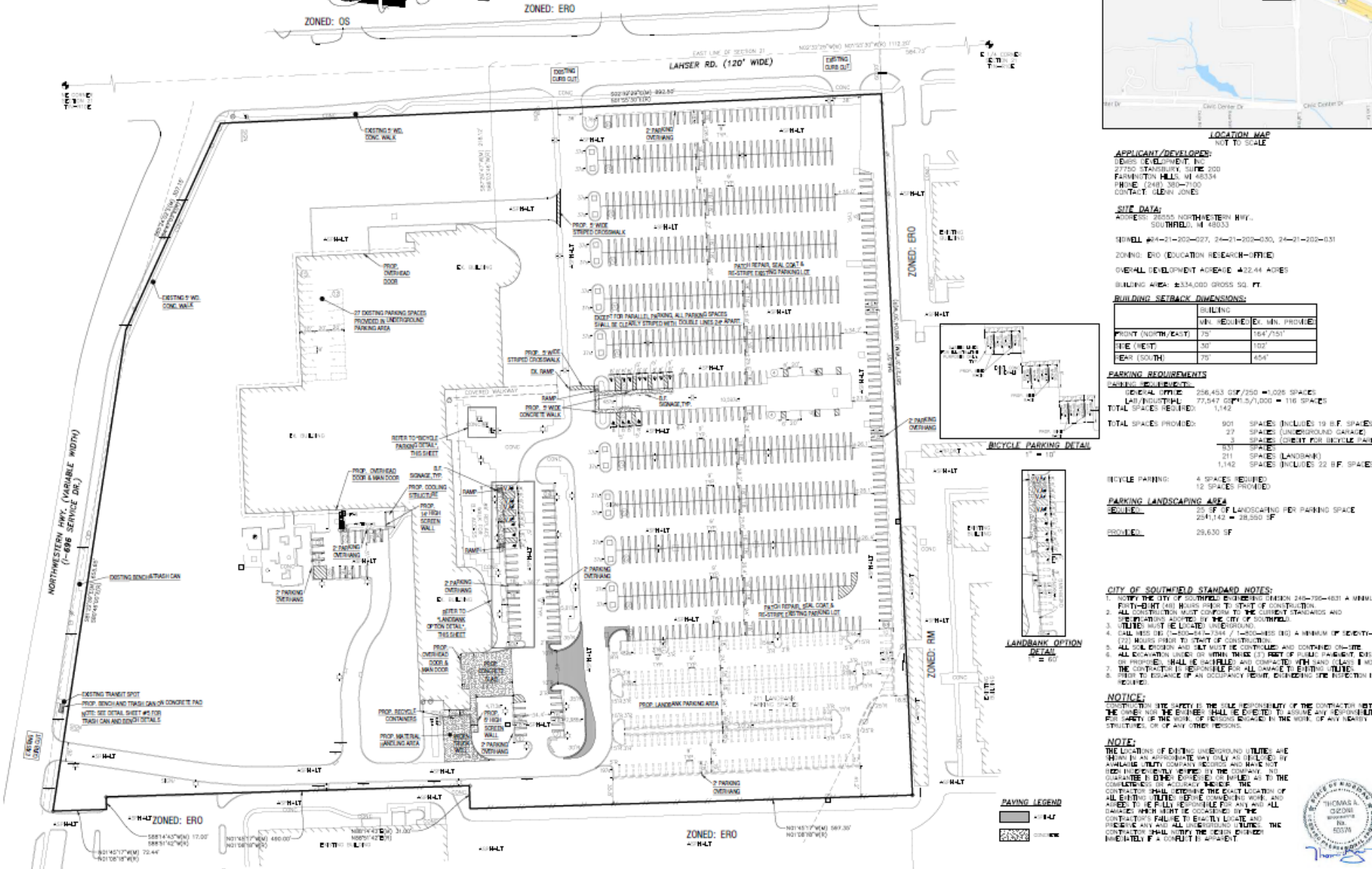

PAVING LEGEND

[Symbol]	ASPH
[Symbol]	CONC
[Symbol]	CONC

- CITY OF SOUTHFIELD STANDARD NOTES:**
1. NOTIFY THE CITY OF SOUTHFIELD ENGINEERING DEPARTMENT (313-287-1400) A MINIMUM OF FIFTY (50) HOURS PRIOR TO START OF CONSTRUCTION.
 2. ALL CONSTRUCTION MUST COMPLY TO THE CURRENT STANDARDS AND REGULATIONS ADOPTED BY THE CITY OF SOUTHFIELD.
 3. UTILITIES MUST BE LOCATED UNDERGROUND.
 4. CALL BEARS (811-888-8111) OR (248) 742-2222 (TOLL-FREE) A MINIMUM OF SEVENTY-TWO (72) HOURS PRIOR TO START OF CONSTRUCTION.
 5. ALL SOIL EROSION AND SILT MUST BE CONTROLLED AND CONTAINED ON-SITE.
 6. ALL EXCAVATION SHIELDING WITHIN THREE (3) FEET OF PUBLIC FACILITY EXISTING OR PROPOSED SHALL BE BACKFILLED AND COMPACTED WITH SAND (CLASS 1) MEDIUM OR FINER TO A MINIMUM OF 18 INCHES TO THE SURFACE OF THE EXCAVATION. THE PROTECTION IS REQUIRED.

NOTICE:
CONSTRUCTION SITE SAFETY IS THE SOLE RESPONSIBILITY OF THE CONTRACTOR. THE CITY OF SOUTHFIELD SHALL NOT BE HELD RESPONSIBLE FOR ANY INJURY OR DAMAGE TO PERSONS OR PROPERTY IN THE WORK OF ANY NEARBY STRUCTURES, OR OF ANY OTHER PERSONS.

NOTE:
THE LOCATIONS OF EXISTING UNDERGROUND UTILITIES ARE SHOWN BY AN APPROXIMATE WAY ONLY AS OBTAINED BY AVAILABLE PUBLIC COMPANY RECORDS AND HAVE NOT BEEN INDIVIDUALLY VERIFIED BY THE COMPANY. NO GUARANTEE IS EITHER EXPRESSED OR IMPLIED AS TO THE CORRECTNESS OR ACCURACY THEREOF. THE CONTRACTOR SHALL DETERMINE THE EXACT LOCATION OF ALL EXISTING UTILITIES BEFORE COMMENCING WORK, AND SHALL BE FULLY RESPONSIBLE FOR ANY DAMAGE TO UTILITIES OCCURRING WHEN ANY IS OCCURRED BY THE CONTRACTOR'S FAILURE TO EXACTLY LOCATE AND PROTECT ANY ALL UNDERGROUND UTILITIES. THE CONTRACTOR SHALL NOTIFY THE DESIGN ENGINEER IMMEDIATELY BY E-MAIL AND TELEPHONE.



For more information, please contact:

BRIAN PIERGENTILI

Executive Managing Director

+1 248 358 6103

brian.piergentili@cushwake.com

JASON COTTON

Transaction Manager

+1 248 358 6105

jason.cotton@cushwake.com



©2023 Cushman & Wakefield. All rights reserved. The information contained in this communication is strictly confidential. This information has been obtained from sources believed to be reliable but has not been verified. NO WARRANTY OR REPRESENTATION, EXPRESS OR IMPLIED, IS MADE AS TO THE CONDITION OF THE PROPERTY (OR PROPERTIES) REFERENCED HEREIN OR AS TO THE ACCURACY OR COMPLETENESS OF THE INFORMATION CONTAINED HEREIN, AND SAME IS SUBMITTED SUBJECT TO ERRORS, OMISSIONS, CHANGE OF PRICE, RENTAL OR OTHER CONDITIONS, WITHDRAWAL WITHOUT NOTICE, AND TO ANY SPECIAL LISTING CONDITIONS IMPOSED BY THE PROPERTY OWNER(S). ANY PROJECTIONS, OPINIONS OR ESTIMATES ARE SUBJECT TO UNCERTAINTY AND DO NOT SIGNIFY CURRENT OR FUTURE PROPERTY PERFORMANCE. COE-PM-WEST- 03/16/23