

FOR LEASE - CLASS A OFFICE SUITES

292 Washington Avenue Extension, Albany, New York 12203



OFFERING SUMMARY

Suite 103:	±1,191 SF - \$1,836/mo
Suite 108:	±907 SF - \$1,400/mo
Suite 109:	±1,075 SF - \$1,612/mo
Zoning:	Commercial
Water:	Municipal
Heat:	GFA
A/C:	Central
Construction:	Brick, Glass
Year Built:	1983
Condition:	Excellent

Property Overview

Class A office space off of Washington Avenue Extension provides convenient access to major highways, shopping malls, and restaurants. This single-story office building with a flexible build out sits near the Albany Pine Bush Reserve.

Owned and managed by:



Robert Murphy | Real Estate Salesperson

+1 518 588 2665 | +1 518 465 1400 ext. 209 | rmurphy@naiplatform.com

James "Jay" Verro, CCIM | Associate Broker

+1 518 369 5048 | +1 518 465 1400 ext. 214 | jverro@ccim.net

FOR LEASE - CLASS A OFFICE SUITES

292 Washington Avenue Extension, Albany, New York 12203

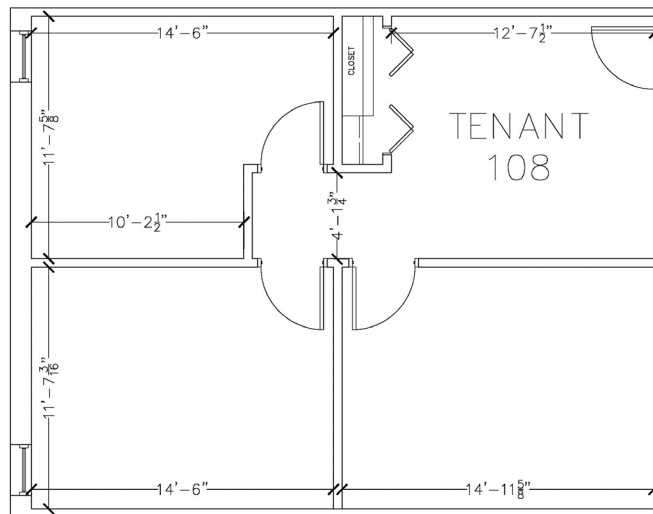
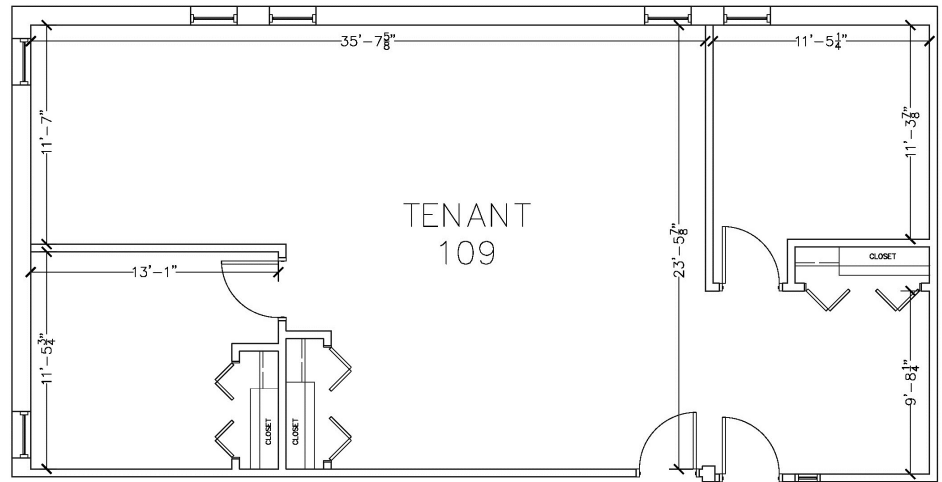
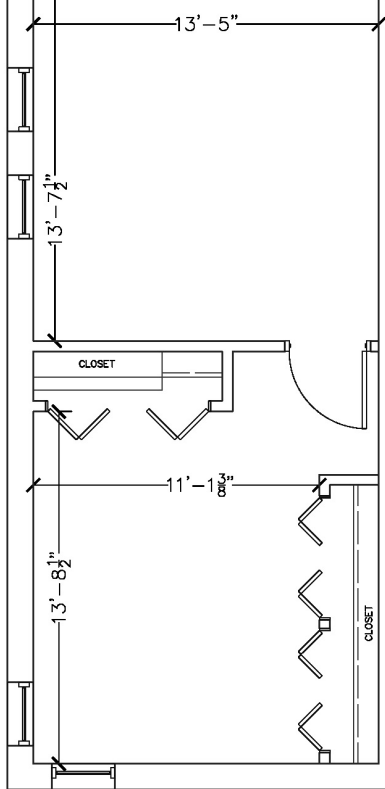
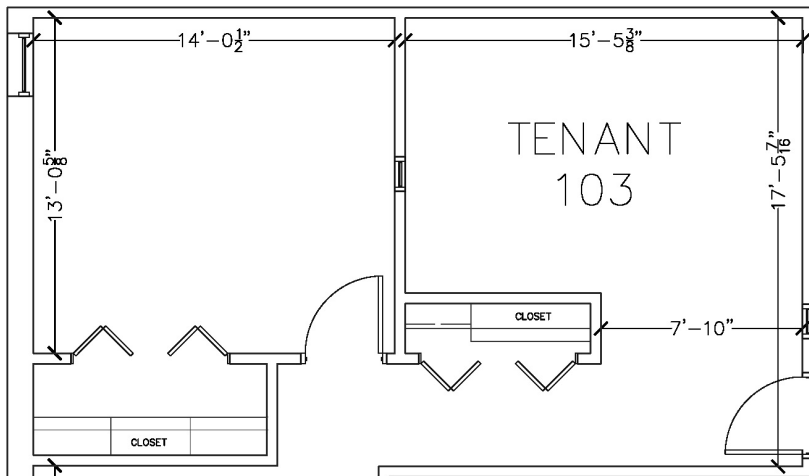

Robert Murphy | Real Estate Salesperson

+1 518 588 2665 | +1 518 465 1400 ext. 209 | rmurphy@naiplatform.com

James "Jay" Verro, CCIM | Associate Broker

+1 518 369 5048 | +1 518 465 1400 ext. 214 | jverro@ccim.net

