



ORANGE RIVER BLVD. - AADT 11,800±

**LSI**  
COMPANIES

OFFERING MEMORANDUM

**ORANGE RIVER BOULEVARD**

28± ACRE RESIDENTIAL DEVELOPMENT OPPORTUNITY

## PROPERTY SUMMARY

**Property Address:** 11920/11940 Orange River Blvd.  
Fort Myers, FL 33905

**County:** Lee

**Property Type:** Residential

**Parcel Size:** 27.86± Acres

**Zoning:** AG-2 (Agricultural 2)

**Future Land Use:** Rural Community Preserve

**Permits In Place:** DOS2023-00153  
(for a 17-lot single family subdivision)

**Utilities:** Well Water

**STRAP Number:** 01-44-25-L3-00005.0000;  
01-44-25-L3-00005.000A

LIST PRICE:

**\$2,895,000**

**LSI**  
**COMPANIES**

LSICOMPANIES.COM



## SALES EXECUTIVE



**Mike Trivett**  
Sales Associate



**DIRECT ALL OFFERS TO:**

**Mike Trivett**

mtrivett@lsicompanies.com

o: (239) 489-4066 m: (239) 940-3171

### OFFERING PROCESS

Offers should be sent via Contract or Letter of Intent to include, but not limited to, basic terms such as purchase price, earnest money deposit, feasibility period and closing period.

## EXECUTIVE SUMMARY

LSI Companies is pleased to present this 28± acre development opportunity in the rural community of Buckingham, Lee County, Florida. Located just 2.6± miles from I-75 (exit 141) on Orange River Boulevard, this property presents both the opportunity for developing a single-family estate home or taking advantage of the in-place approved Development Order and Permit for a 17-lot single-family subdivision.

### PROPERTY FEATURES

- 1± acre pond
- Graded roadway
- Recently constructed pole barn (2024)
- Fences surrounding the property line and linear fences dividing sections of the property

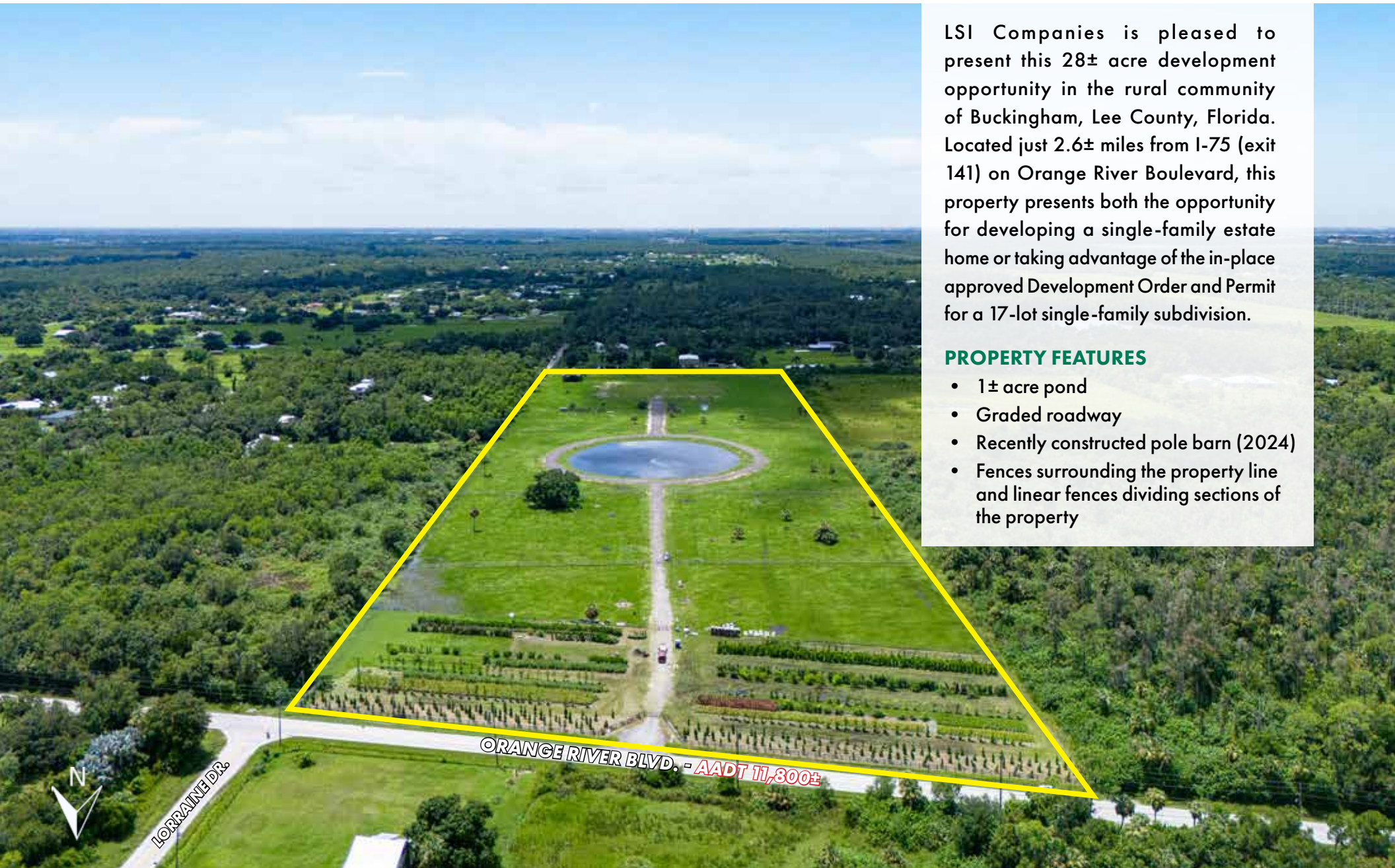

# PROPERTY AERIAL



THE HOME DEPOT TARGET HYATT PLACE TACO BELL Culver's Chick-fil-A TEXAS ROADHOUSE 7-ELEVEN SUBWAY KOHL'S Walmart LOWE'S DUNKIN' DONUTS ROSS DRESS FOR LESS tropical CAFE TRUIST # Home Depot KEISER UNIVERSITY TESLA HOBBY LOBBY

CYPRESS WOODS BY RESORT CAMPING WORLD FERGUSON

DOWNTOWN FORT MYERS



HOMESTEAD LANE

ORANGE RIVER BLVD. - AADT 11,800±

CEDAR HAMMOCK CT.

WILLIAMSON ROAD



# PROPERTY AERIAL



## SITE CONSTRUCTION PLANS

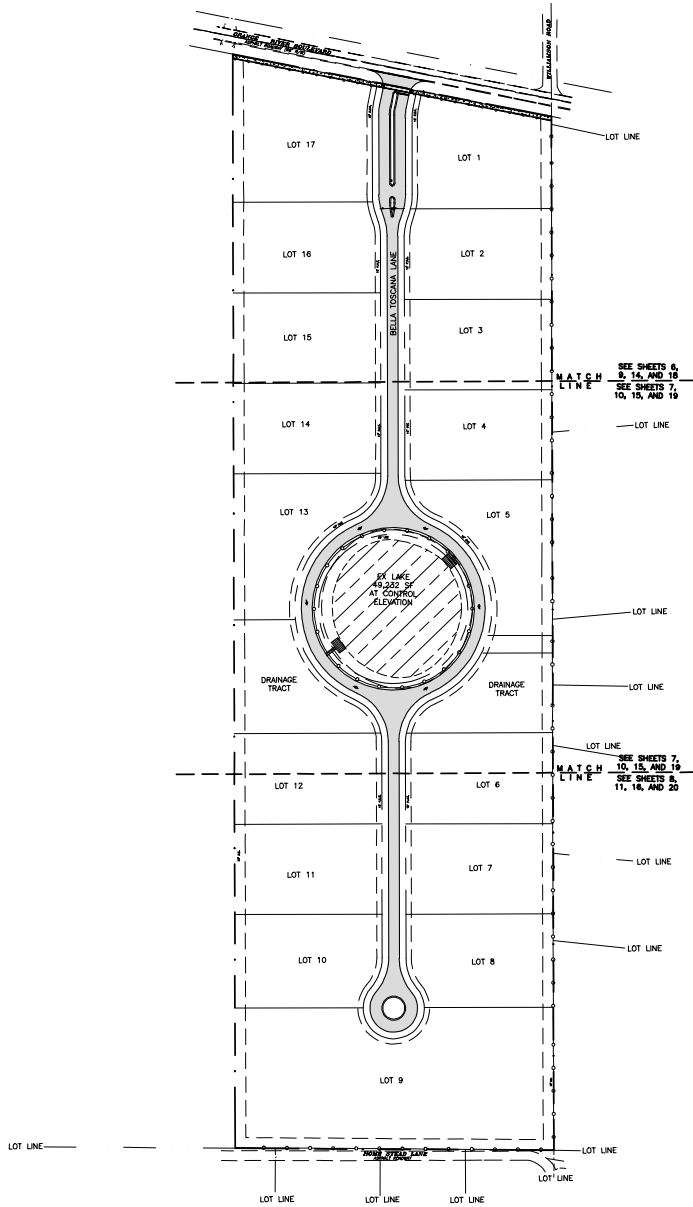

## LANDSCAPE PLANS

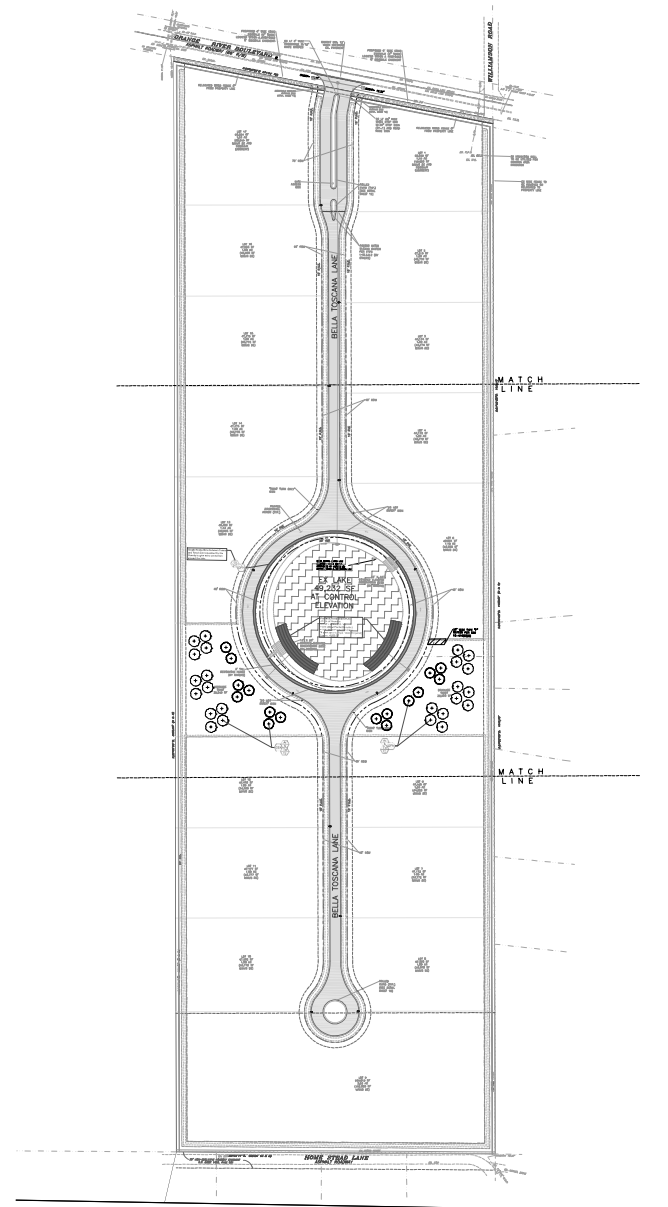

## NEARBY DEVELOPMENTS MAP

1. **ORANGE RIVER 130**  
*Residential Planned Development*
2. **HORSE CREEK COMMUNITY**  
*113 Estate Sized Home Sites*
3. **ORANGE RIVER BOULEVARD RPD**  
*In Permitting Construction: 57-Unit Single Family Residential Subdivision*
4. **STARBUCKS**  
*Under Construction: New 2,526 Sq. Ft. Starbucks with Drive Through*
5. **La Quinta by Wyndham**  
*Proposed Development: 83-unit Hotel*



# RETAIL MAP



**TACO BELL** Suncoast Credit Union **Big Lots!** **Save a lot** extended STAY AMERICA **CIRCLE K** **Waffle House**

**Publix** **Walgreens** **Regions** **First Bank** **Mobil** **7-Eleven** **Wells Fargo**

**ACE Hardware** **Winn-Dixie** **CIRCLE K** **SUNOCO** **Publix** **Dunkin' Donuts** **Wendy's** **Advance Auto Parts** **TRUIST** **CVS pharmacy** **DOLLAR GENERAL**

**The Home Depot** **Target** **Hyatt Place** **Taco Bell** **Culver's** **Chick-fil-A** **Subway** **Kohl's** **Walmart** **7-Eleven** **Lowe's** **Dunkin' Donuts** **Ross Dress for Less** **Tropical Cafe** **TRUIST** **Keiser University** **Tesla** **Hobby Lobby**





## LOCATION MAP

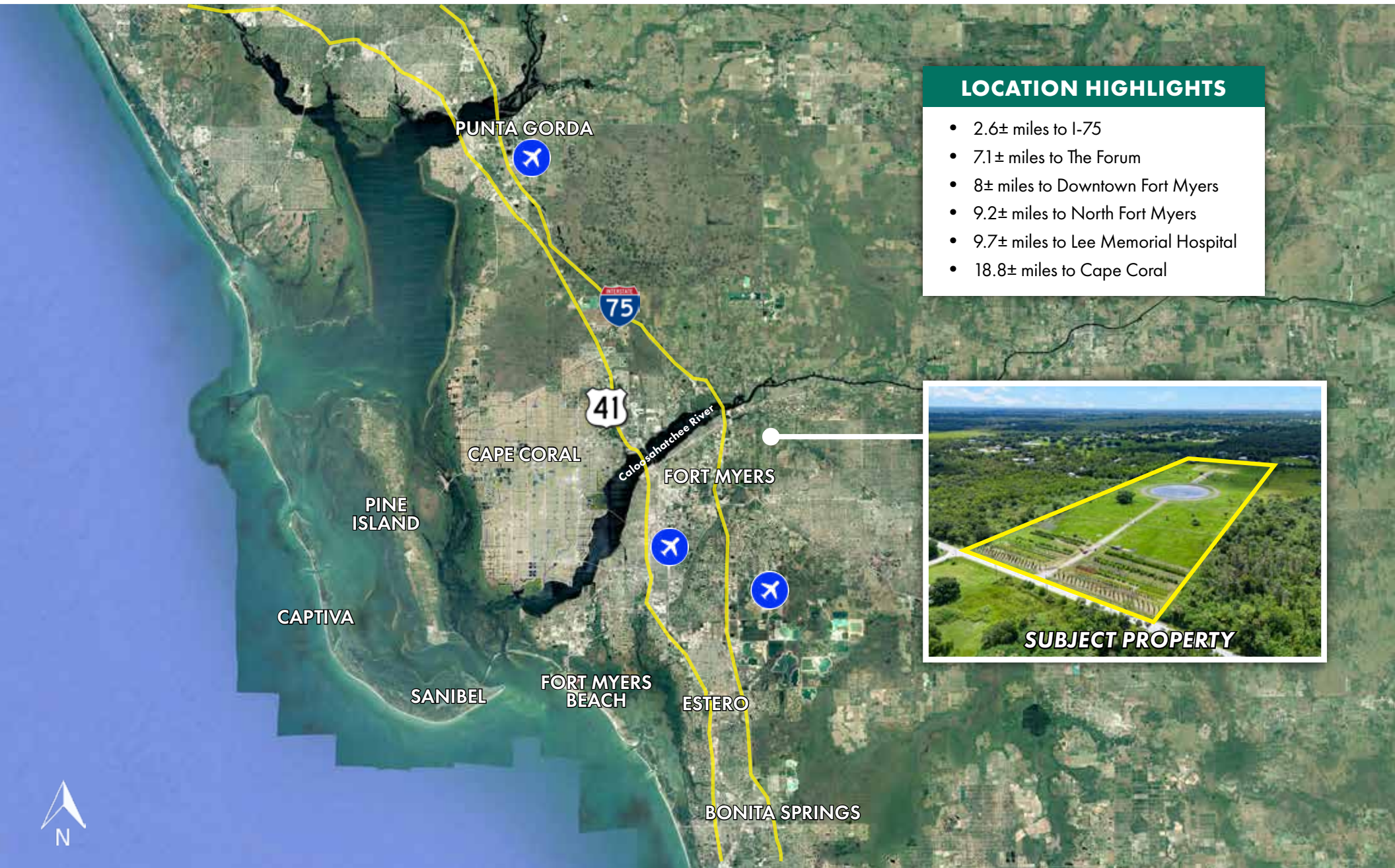

### LOCATION HIGHLIGHTS

- 2.6± miles to I-75
- 7.1± miles to The Forum
- 8± miles to Downtown Fort Myers
- 9.2± miles to North Fort Myers
- 9.7± miles to Lee Memorial Hospital
- 18.8± miles to Cape Coral



**SUBJECT PROPERTY**





# LSI COMPANIES

LSICOMPANIES.COM

## LIMITATIONS AND DISCLAIMERS

The content and condition of the property provided herein is to the best knowledge of the Seller. This disclosure is not a warranty of any kind; any information contained within this proposal is limited to information to which the Seller has knowledge. Information in this presentation is gathered from reliable sources, and is deemed accurate, however any information, drawings, photos, site plans, maps or other exhibits where they are in conflict or confusion with the exhibits attached to an forthcoming purchase and sale agreement, that agreement shall prevail. It is not intended to be a substitute for any inspections or professional advice the Buyer may wish to obtain. An independent, professional inspection is encouraged and may be helpful to verify the condition of the property. The Seller and LSI Companies disclaim any responsibility for any liability, loss or risk that may be claimed or incurred as a consequence of using this information. Buyer to hold any and all person's involved in the proposal of the property to be held harmless and keep them exonerated from all loss, damage, liability or expense occasioned or claimed. Potential Buyer acknowledges that all property information, terms and conditions of this proposal are to be kept confidential, and concur that either the Potential Buyers, nor their agents, affiliates or attorneys will reveal this information to, or discuss with, any third parties. Buyer will be a qualified Buyer with significant experience in entitlement and development process in Lee County with finesse and wherewithal and be willing to be interviewed by the LSI Companies team.