

Normandale Place

8201 Norman Center Drive | Bloomington, MN 55437



\$2/RSF Broker Fee if Lease Executed By August 31st



OFFICE SPACE FOR LEASE

Space Available: 2,545- 18,290 RSF

NNN Rate: \$13.00/RSF

2026 OPEX & RE Taxes: \$10.79/RSF

Operating Expenses: \$6.51/RSF

RE Taxes: \$4.28/RSF

- Access to I-494 and Hwy 100. 169 and I-35W
- Large training room
- Break room
- Fitness Center
- Lots of natural light
- Monument signage available
- Controlled access entry system
- Foodsby
- Minutes from the MSP Airport
- Close proximity to restaurants, hotels, shopping, Caribou Coffee, and Life Time Fitness.
- Normandale Lake Park with walking and biking trail nearby.

Jeff Houg

D: 952-300-9545

M: 612-889-2242

jhoug@shcre.com

www.shcre.com



Normandale Place

8201 Norman Center Drive | Bloomington, MN 55437

Jeff Houg

D: 952-300-9545

M: 612-889-2242

jhoug@shcre.com

www.shcre.com

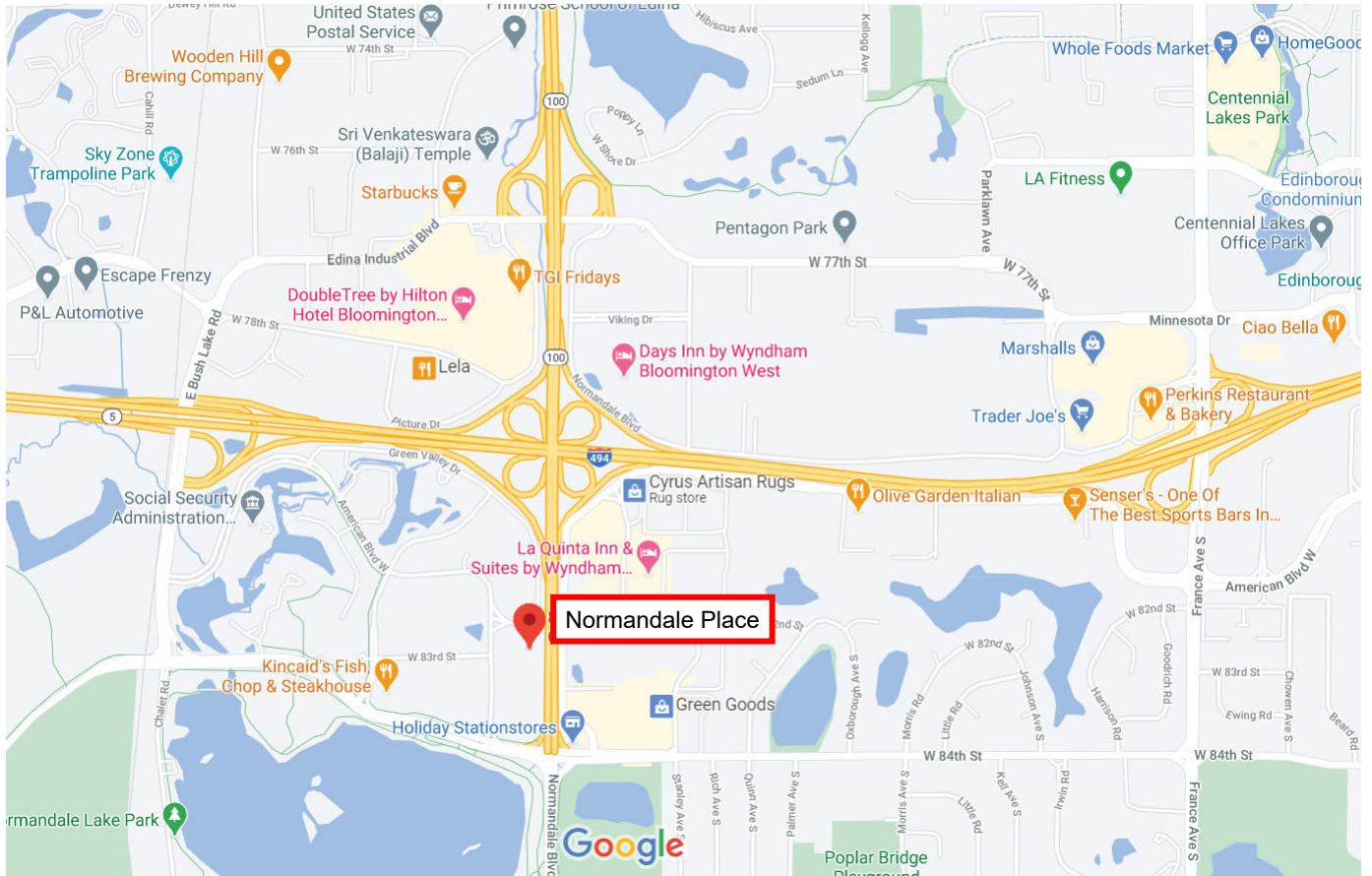

Normandale Place

8201 Norman Center Drive | Bloomington, MN 55437

Jeff Houg

D: 952-300-9545

M: 612-889-2242

jhoug@shcre.com

www.shcre.com

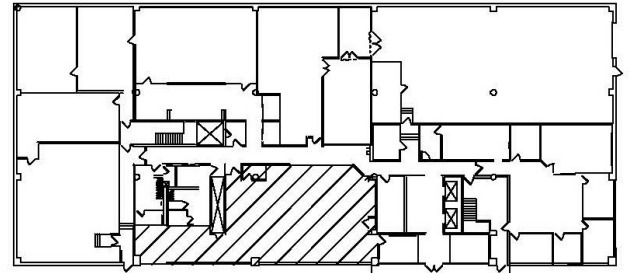

Key Plan - 1st Floor

Suite 100 - 2,545 RSF

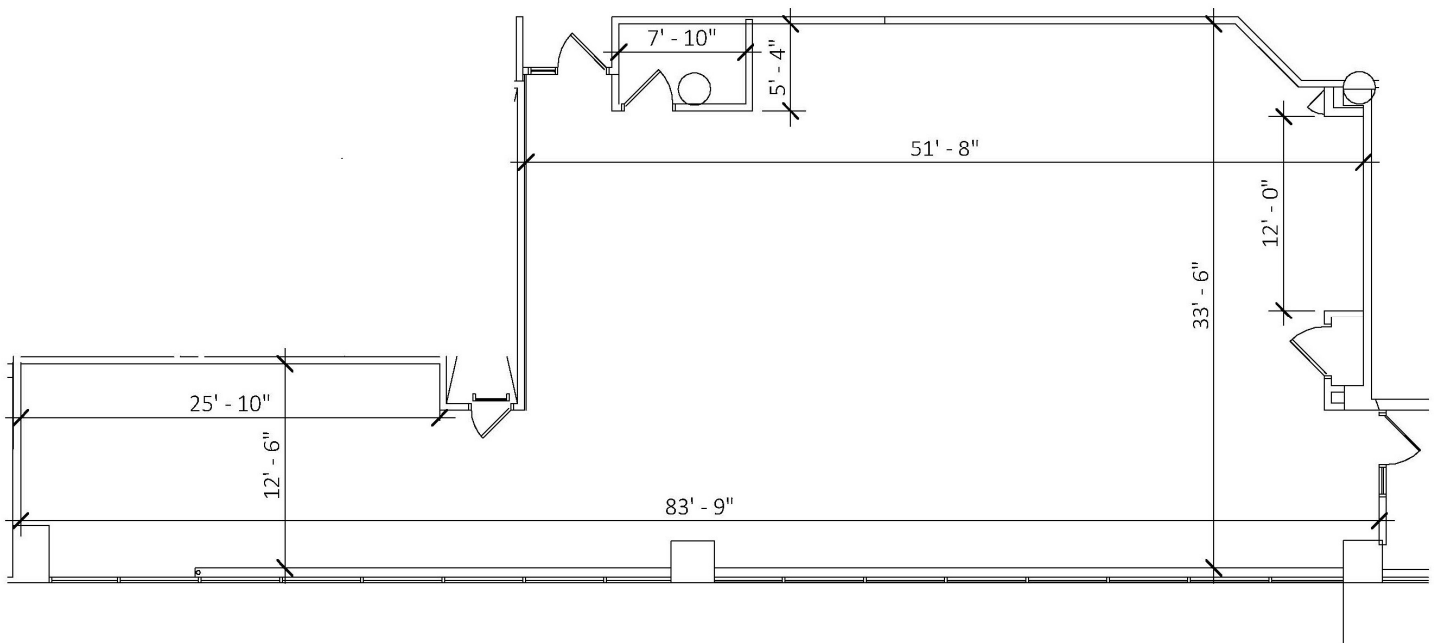

Normandale Place

8201 Norman Center Drive | Bloomington, MN 55437

Jeff Houg

D: 952-300-9545

M: 612-889-2242

jhoug@shcre.com

www.shcre.com



Suite 230 - 3,476 RSF

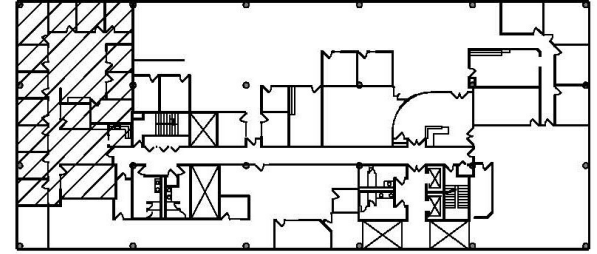
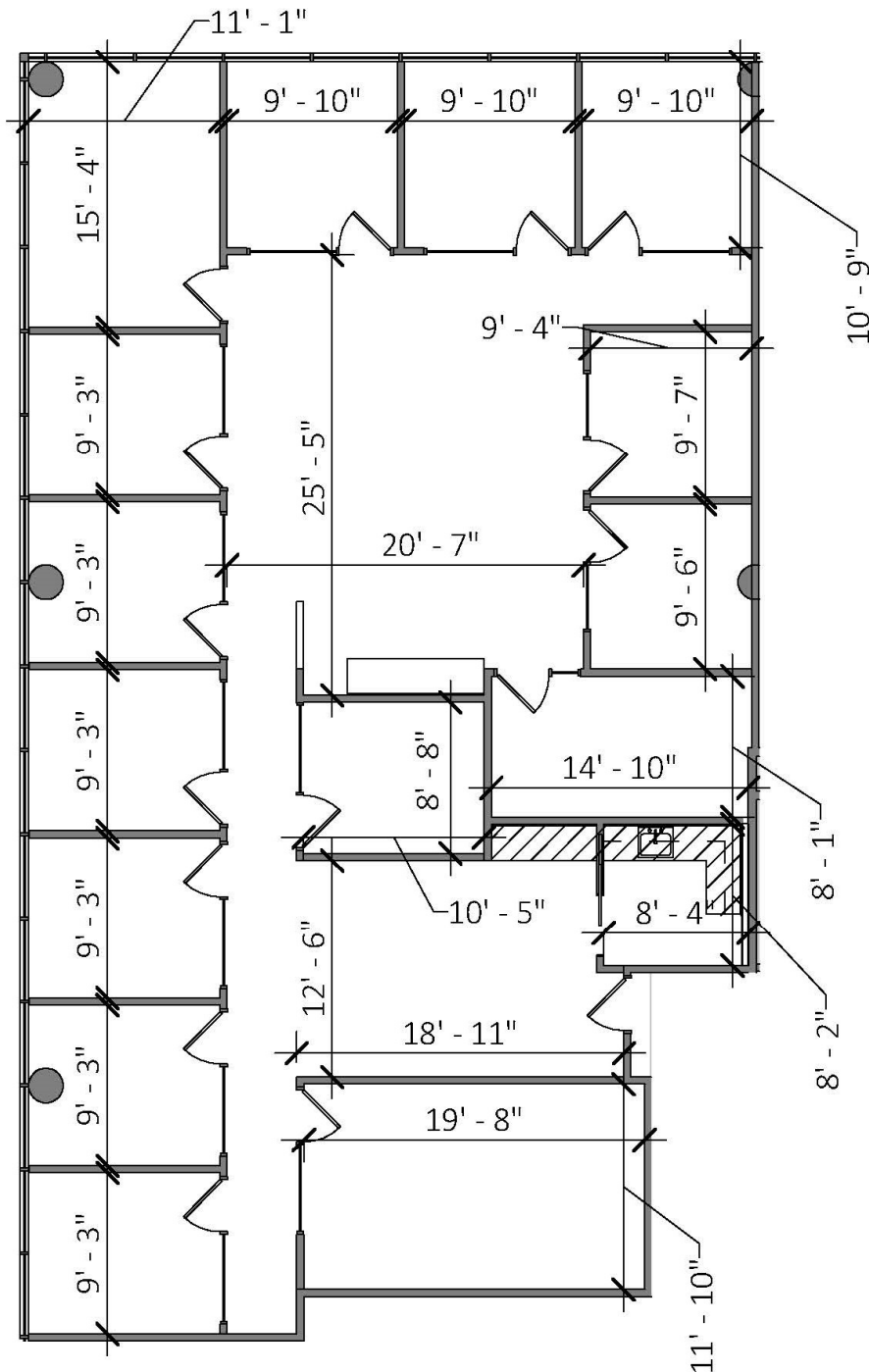

Key Plan - 2ND Floor

Normandale Place

8201 Norman Center Drive | Bloomington, MN 55437

Jeff Houg

D: 952-300-9545

M: 612-889-2242

jhoug@shcre.com

www.shcre.com



- Entire 3rd Floor
- Elevator Access
- Private bathrooms and shower



Suite 300 - 18,290 RSF

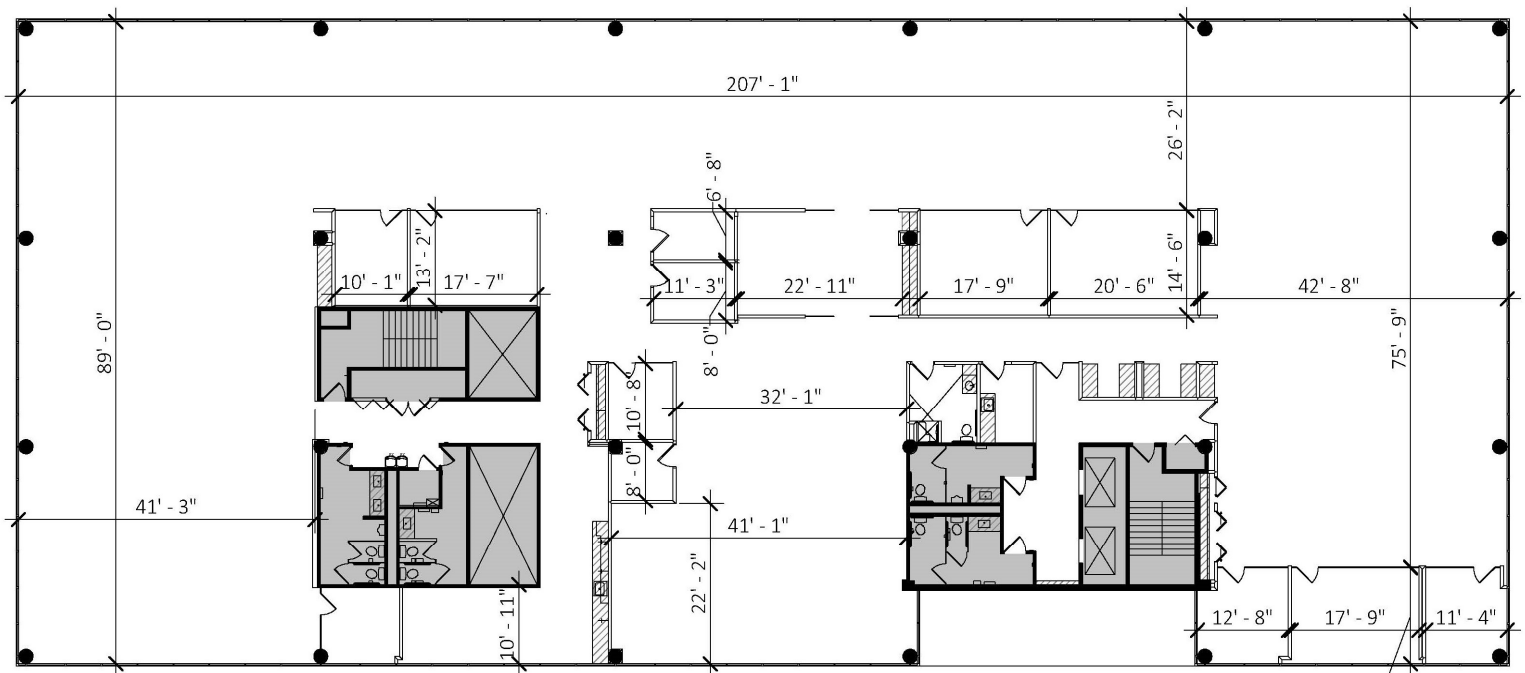

Normandale Place

8201 Norman Center Drive | Bloomington, MN 55437

Jeff Houg

D: 952-300-9545

M: 612-889-2242

jhoug@shcre.com

www.shcre.com

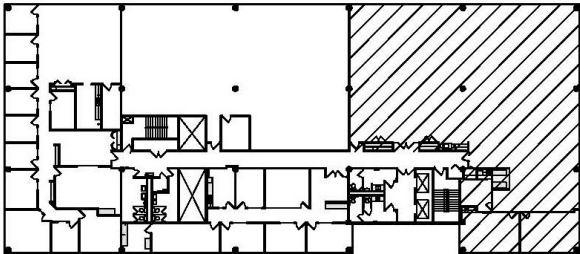

Key Plan - 4th Floor

Suite 400 - 7,021 RSF

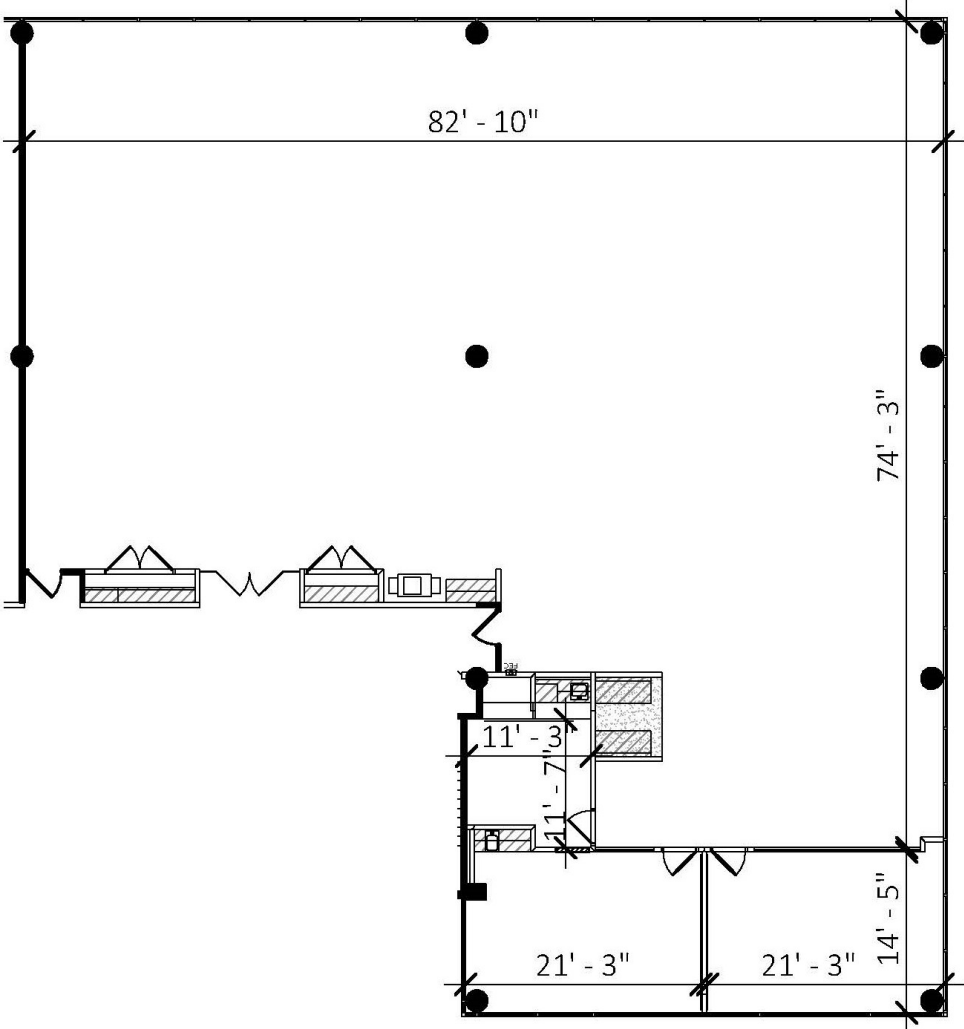

Normandale Place

8201 Norman Center Drive | Bloomington, MN 55437

Jeff Houg

D: 952-300-9545

M: 612-889-2242

jhoug@shcre.com

www.shcre.com

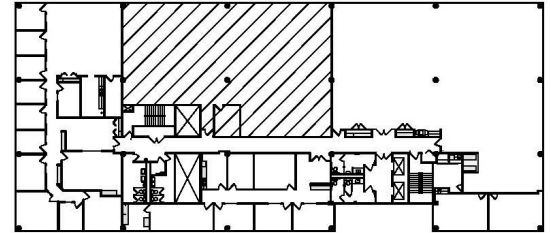

Key Plan - 4th Floor

Suite 410 - 4,635 RSF

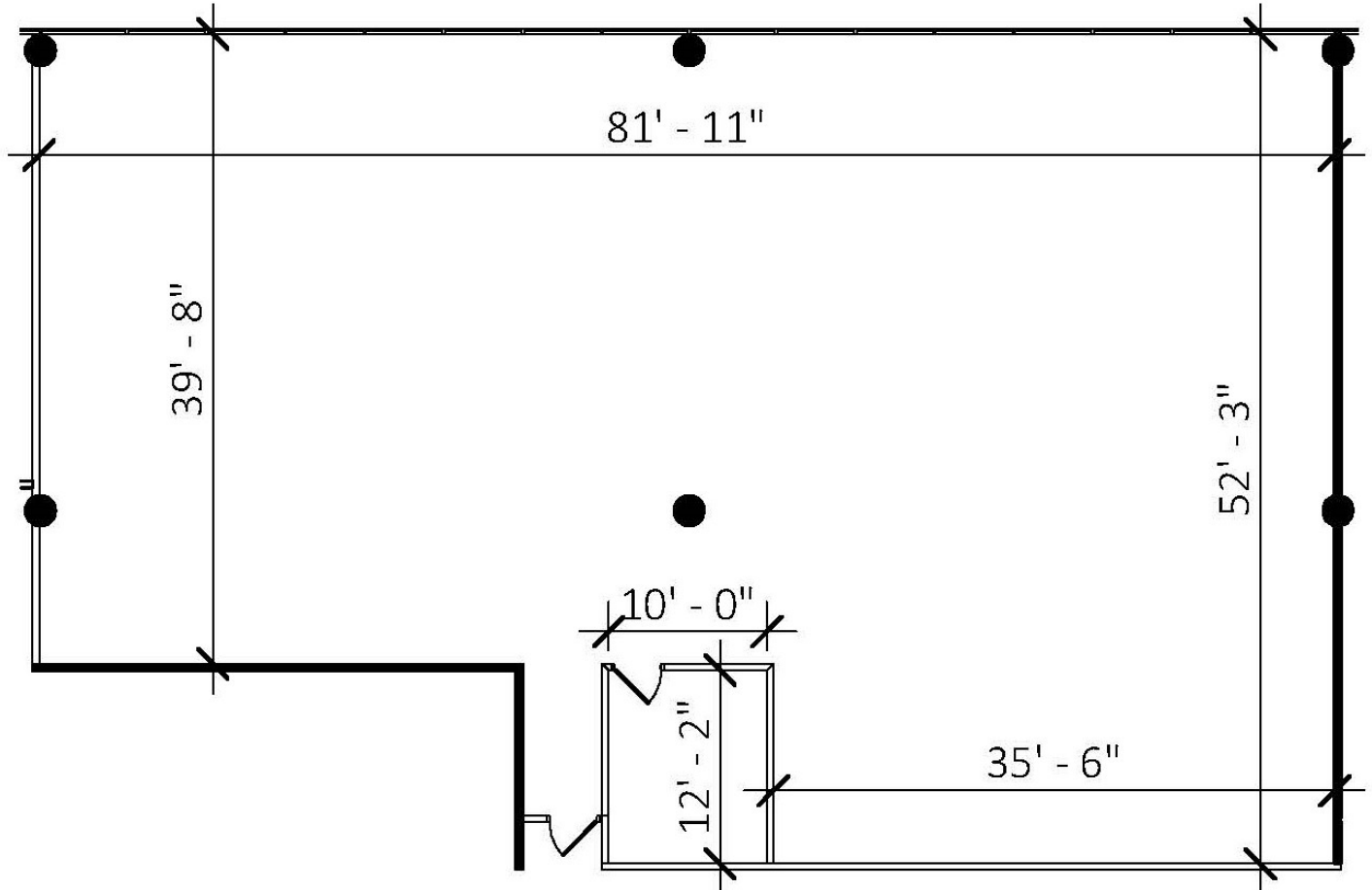

Normandale Place

8201 Norman Center Drive | Bloomington, MN 55437

Jeff Houg

D: 952-300-9545

M: 612-889-2242

jhoug@shcre.com

www.shcre.com



Suite 450- 4,418 RSF

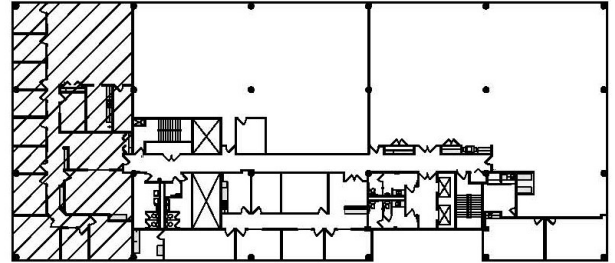

Key Plan - 4th Floor

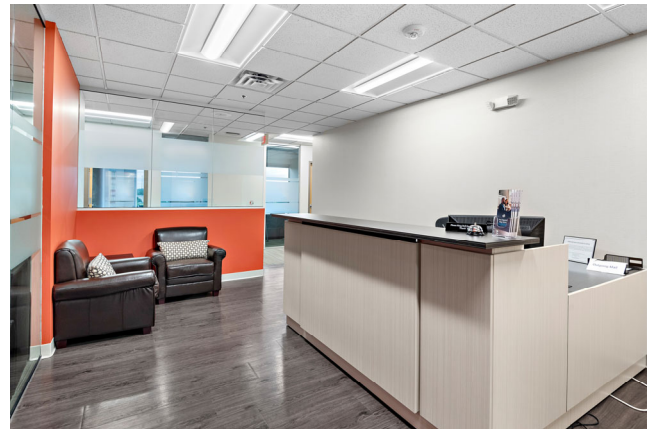
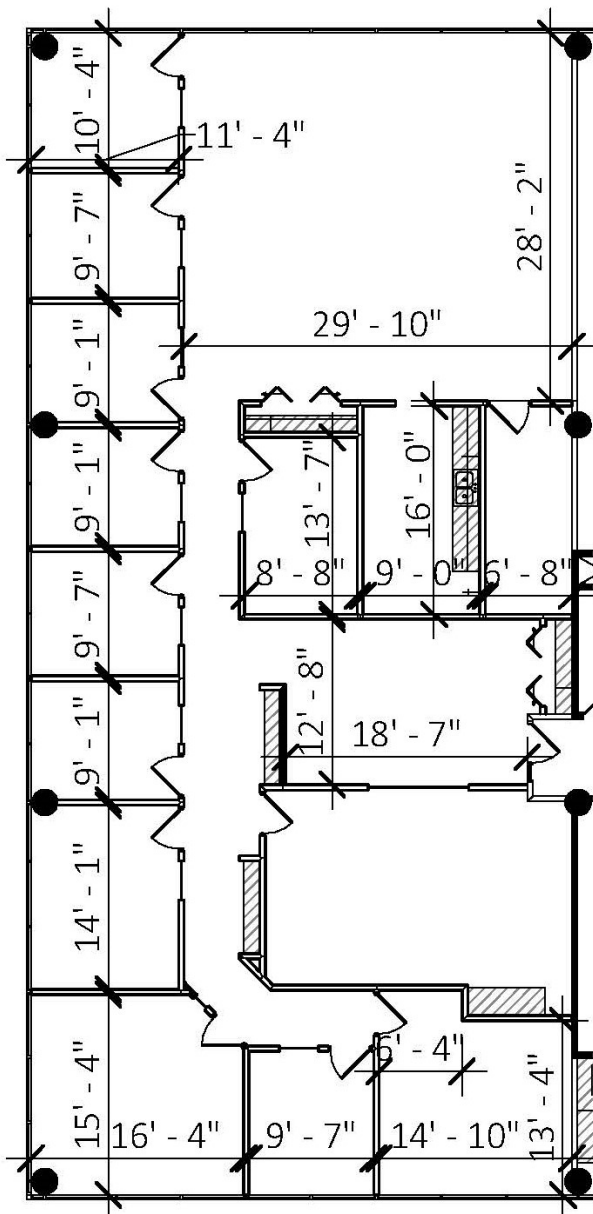

Normandale Place

8201 Norman Center Drive | Bloomington, MN 55437

Jeff Houg

D: 952-300-9545

M: 612-889-2242

jhoug@shcre.com

www.shcre.com



- Entire 5th Floor
- Elevator Access
- Private bathrooms



Suite 500- 18,290 RSF

