

# For Lease 1126 Main Ave (Hwy 101), Tillamook

**23,205 SF Divisible**  
**\$0.75 Per Square Foot**  
**Negotiable for Large User**



## HIGHLY VISIBLE RETAIL/OFFICE SPACE FOR LEASE

Hard to find, large, Hwy 101 commercial space in Downtown Tillamook, adjacent to Les Schwab and new Napa Auto Parts store.

23,205 SF available. Lease rate dependent on location and type of space within building; ground floor retail, warehouse, mezzanine. Tenant improvements negotiable based on lease term, square footage, credit worthiness, etc. Building signage & parking available on site.



**See reverse for floor plan**  
**Monument signage**  
**available**



**BERKSHIRE  
HATHAWAY**  
HomeServices

**Northwest Real Estate**

**COMMERCIAL**

**OregonCoastCommercial.com**

Valerie Schumann, *Principal Broker*  
Office: 971-265-1070  
Cell: 503-812-8423  
vschumann@bhhsnw.com  
406 Garibaldi Avenue Garibaldi, Oregon

# 1126 Main Ave (Hwy 101), Tillamook - Floor Plan Available Space

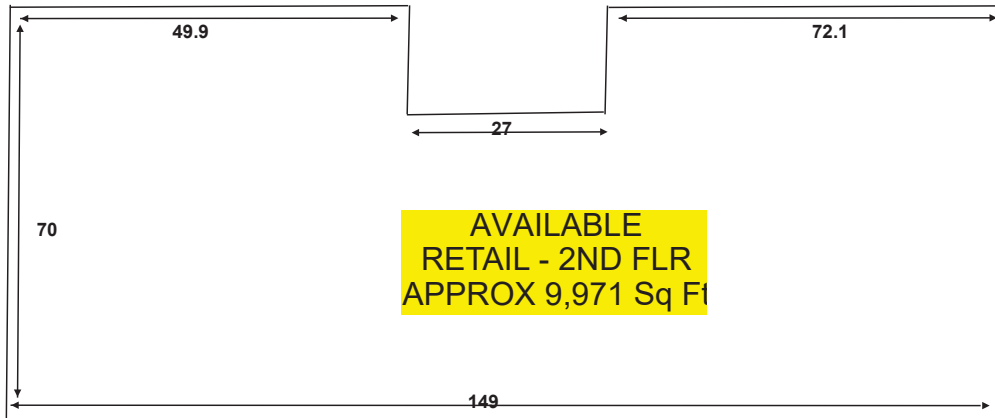

All dimensions are approximate and may not reflect the "true"

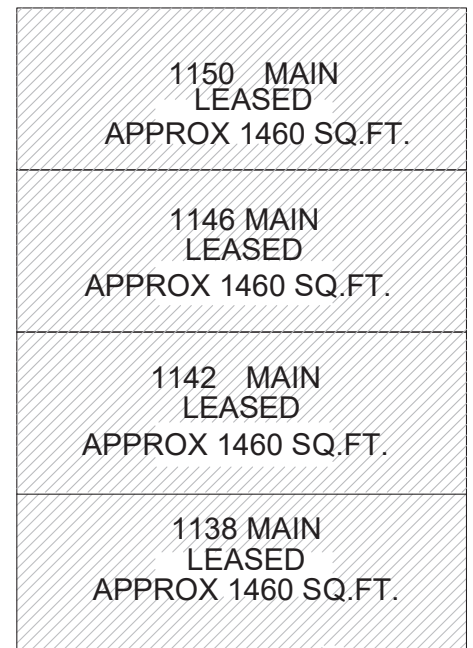

Valerie Schumann, *Principal Broker*

Office: 971-265-1070

Cell: 503-812-8423

vschumann@bhhsnw.com

406 Garibaldi Avenue Garibaldi, Oregon

**OregonCoastCommercial.com**

