





**SURVEY PLAT**

TO ALL PARTIES INTERESTED IN PREMISES SURVEYED.

THIS IS TO CERTIFY THAT I HAVE, THIS DATE, MADE A CAREFUL AND ACCURATE SURVEY ON THE GROUND OF FOLLOWING DESCRIBED PROPERTY.

BEING ALL THAT CERTAIN LOT, TRACT OR PARCEL OF LAND SITUATED IN THE CITY OF PLANO, COLLIN COUNTY, TEXAS, OUT OF THE HENRY B. MILLER SURVEY, ABSTRACT NO. 614 AND THE COLLIN COUNTY SCHOOL LAND SURVEY, ABSTRACT NO. 150 AND BEING A PART OF THE CALLED 85.00 ACRE TRACT OF LAND DESCRIBED IN DEED TO LAVERNE W. BACCUS TRUSTEE FOR EARLANE B. CROOM AS RECORDED IN VOLUME 1694 AT PAGE 825 OF THE DEED RECORDS OF COLLIN COUNTY, AND BEING ALL OF LOT 2, BLOCK A, OF EARL BACCUS # 1 ADDITION, AN ADDITION TO THE CITY OF PLANO, COLLIN COUNTY, TEXAS ACCORDING TO THE PLAT THEREOF RECORDED IN INSTRUMENT NO. 20161206010005150, AND VOLUME 2016, PAGE 862 OF THE OF THE OFFICIAL PUBLIC RECORDS OF COLLIN COUNTY, TEXAS AND BEING MORE PARTICULARLY DESCRIBED BY METES AND BOUNDS AS FOLLOWS:

**BEGINNING** AT A 5/8" IRON ROD SET FOR CORNER AT THE SOUTH END OF A CORNER CLIP AT THE INTERSECTION OF NORTH RIGHT-OF-WAY LINE OF SPRING CREEK PARKWAY (VARIABLE WIDTH RIGHT OF WAY) AND THE NORTHWEST RIGHT-OF-WAY LINE OF COMMUNICATIONS PARKWAY (VARIABLE WIDTH RIGHT OF WAY);

**THENCE** SOUTH 89° 04' 38" WEST AND FOLLOWING ALONG THE NORTH RIGHT-OF-WAY LINE OF SAID SPRING CREEK PARKWAY, FOR A DISTANCE OF 456.95 FEET TO A 5/8" IRON ROD WITH YELLOW PLASTIC CAP STAMPED "RPLS1890" FOUND FOR CORNER, SAID POINT BEING THE BEGINNING OF A CURVE TO THE LEFT HAVING A RADIUS OF 1320.50 FEET WITH A CENTRAL ANGLE OF 26° 13' 05" AND A CHORD BEARING NORTH 77° 48' 50" WEST AT A DISTANCE OF 598.76 FEET;

**THENCE** NORTHWESTERLY AND FOLLOWING ALONG SAID CURVE TO THE RIGHT AND FOLLOWING ALONG THE NORTH RIGHT-OF-WAY LINE OF SAID SPRING CREEK PARKWAY FOR AN ARC DISTANCE OF 604.02 FEET TO A 5/8" IRON ROD WITH YELLOW PLASTIC STAMP STAMPED "RPLS 1890" FOUND FOR CORNER;

**THENCE** NORTH 64° 42' 17" WEST AND CONTINUING ALONG THE NORTH RIGHT-OF-WAY LINE OF SAID SPRING CREEK PARKWAY FOR A DISTANCE OF 699.13 FEET TO A 5/8" IRON ROD WITH YELLOW PLASTIC CAP STAMPED "RPLS 1890" FOUND FOR CORNER, SAID POINT BEING THE SOUTH END OF A CORNER CLIP AT THE INTERSECTION OF THE NORTH RIGHT-OF-WAY LINE OF SAID SPRING CREEK PARKWAY AND THE SOUTHEAST RIGHT-OF-WAY LINE OF TENNYSON PARKWAY (VARIABLE WIDTH RIGHT OF WAY);

**THENCE** NORTH 19° 17' 59" WEST AND FOLLOWING ALONG SAID CORNER CLIP, FOR A DISTANCE OF 36.04 FEET TO AN ALUMINUM MONUMENT FOUND FOR CORNER, SAID POINT BEING THE NORTH END OF SAID CORNER CLIP AND BEING IN THE SOUTHEAST RIGHT-OF-WAY LINE OF SAID TENNYSON PARKWAY;

**THENCE** FOLLOWING THE SOUTHEAST RIGHT-OF-WAY LINE OF SAID TENNYSON PARKWAY, THE FOLLOWING COURSES AND DISTANCES NUMBERED (1) THROUGH (6);

(1) NORTH 25° 26' 44" EAST FOR A DISTANCE OF 174.65 FEET TO A 1" IRON ROD FOUND FOR CORNER;

(2) NORTH 21° 38' 22" EAST FOR A DISTANCE OF 150.31 FEET TO A 1" IRON ROD FOUND FOR CORNER;

(3) NORTH 25° 42' 23" EAST FOR A DISTANCE OF 140.59 FEET TO A 5/8" IRON ROD WITH YELLOW PLASTIC CAP STAMPED "RPLS 1890" FOUND FOR CORNER;

(4) NORTH 25° 54' 16" EAST FOR A DISTANCE OF 144.40 FEET TO A 5/8" IRON ROD WITH YELLOW PLASTIC CAP STAMPED "RPLS 1890" FOUND FOR CORNER SAID POINT BEING THE BEGINNING OF A CURVE TO THE RIGHT HAVING A RADIUS OF 1225.00 FEET WITH A CENTRAL ANGLE OF 12° 25' 29" AND A CHORD BEARING NORTH 33° 25' 40" EAST AT A DISTANCE OF 459.90 FEET;

(5) NORTHEASTERLY AND FOLLOWING ALONG SAID CURVE TO THE RIGHT FOR AN ARC DISTANCE OF 450.81 FEET TO A 5/8" IRON ROD FOUND FOR CORNER, SAID POINT BEING THE BEGINNING OF A CURVE TO THE RIGHT HAVING A RADIUS OF 1000.00 FEET WITH A CENTRAL ANGLE OF 5° 33' 17" AND A CHORD BEARING NORTH 42° 21' 27" EAST AT A DISTANCE OF 96.91 FEET;

(6) NORTHEASTERLY AND FOLLOWING ALONG SAID CURVE TO THE RIGHT FOR AN ARC DISTANCE OF 96.95 FEET TO AN ALUMINUM MONUMENT FOUND FOR CORNER, SAID POINT BEING THE NORTHWEST CORNER OF AFORESAID LOT 2, BLOCK A, OF EARL BACCUS # 1 ADDITION, AND THE SOUTHWEST CORNER OF LOT 1, BLOCK A, OF TENCOOP CENTER ADDITION, AN ADDITION TO THE CITY OF PLANO, COLLIN COUNTY, TEXAS ACCORDING TO THE PLAT THEREOF RECORDED IN VOLUME 2018, PAGE 952 OF THE OFFICIAL PUBLIC RECORDS OF COLLIN COUNTY, TEXAS;

**THENCE** NORTH 89° 12' 24" EAST AND DEPARTING THE SOUTHEAST RIGHT-OF-WAY LINE OF SAID TENNYSON PARKWAY, AND FOLLOWING ALONG THE NORTH LINE OF AFORESAID LOT 2, BLOCK A, OF EARL BACCUS # 1 ADDITION AND 85 ACRE TRACT OF LAND DESCRIBED IN DEED TO CROOM INTERESTS, LTD AS RECORDED IN VOLUME 4802 AT PAGE 3519 OF THE DEED RECORDS OF COLLIN COUNTY, TEXAS AND COMMON TO THE SOUTH LINE OF SAID LOT 1, BLOCK A OF TENCOOP CENTER ADDITION, FOR A DISTANCE OF 605.76 FEET TO A POINT FOR CORNER, SAID POINT BEING THE NORTHEAST CORNER OF AFORESAID LOT 2 AND THE NORTHWEST CORNER OF LOT 1, IN BLOCK A, OF AFORESAID EARL BACCUS # 1 ADDITION;

**THENCE** SOUTH 00° 49' 29" EAST ALONG THE COMMON LINE OF SAID LOTS 1 AND 2 IN BLOCK A OF AFORESAID EARL BACCUS # 1 ADDITION, FOR A DISTANCE OF 578.68 FEET TO A 1/2" IRON ROD FOUND FOR CORNER, SAID POINT BEING THE SOUTHEAST CORNER OF AFORESAID LOT 2 AND THE SOUTHWEST CORNER OF SAID LOT 1, IN BLOCK A, OF EARL BACCUS # 1 ADDITION;

**THENCE** NORTH 89° 08' 58" EAST ALONG THE SOUTH LINE OF SAID LOT 1, IN BLOCK A, OF EARL BACCUS # 1 ADDITION, FOR A DISTANCE OF 526.40 FEET TO A 5/8" IRON ROD WITH YELLOW PLASTIC CAP STAMPED "STANTEC" FOUND FOR CORNER;

**THENCE** SOUTH 50° 48' 24" EAST CONTINUING ALONG THE SOUTH LINE OF SAID LOT 1, IN BLOCK A, OF EARL BACCUS # 1 ADDITION, FOR A DISTANCE OF 245.86 FEET TO A 5/8" IRON ROD WITH YELLOW PLASTIC CAP STAMPED "STANTEC" FOUND FOR CORNER IN THE NORTHWEST RIGHT-OF-WAY LINE OF AFORESAID COMMUNICATIONS PARKWAY, SAID POINT BEING THE BEGINNING OF A CURVE TO THE LEFT HAVING A RADIUS OF 1075.02 FEET, WITH A CENTRAL ANGLE OF 22° 16' 38" AND A CHORD BEARING SOUTH 22° 41' 26" WEST AT A DISTANCE OF 415.35 FEET;

**THENCE** SOUTHWESTERLY AND FOLLOWING ALONG SAID CURVE TO THE LEFT AND ALONG THE NORTHWEST RIGHT-OF-WAY LINE OF AFORESAID COMMUNICATIONS PARKWAY FOR AN ARC DISTANCE OF 417.98 FEET TO A 5/8" IRON ROD WITH YELLOW PLASTIC CAP STAMPED "RPLS 1890" FOUND FOR CORNER, SAID POINT BEING THE BEGINNING OF A CURVE TO THE LEFT HAVING A RADIUS OF 1104.91 FEET, WITH A CENTRAL ANGLE OF 08° 15' 06" AND A CHORD BEARING SOUTH 10° 56' 06" WEST AT A DISTANCE OF 158.99 FEET;

**THENCE** SOUTHWESTERLY AND FOLLOWING ALONG SAID CURVE TO THE LEFT AND CONTINUING ALONG THE NORTHWEST RIGHT-OF-WAY LINE OF AFORESAID COMMUNICATIONS PARKWAY FOR AN ARC DISTANCE OF 159.13 FEET TO A 5/8" IRON ROD WITH YELLOW PLASTIC CAP STAMPED "RPLS 1890" FOUND FOR CORNER;

**THENCE** SOUTH 01° 23' 14" WEST AND CONTINUING ALONG THE NORTHWEST RIGHT-OF-WAY LINE OF AFORESAID COMMUNICATIONS PARKWAY FOR A DISTANCE OF 65.84 FEET TO A 5/8" IRON ROD WITH YELLOW PLASTIC CAP STAMPED "RPLS 1890" FOUND FOR CORNER;

**THENCE** SOUTH 46° 21' 59" WEST ALONG SAID CORNER CLIP FOR A DISTANCE OF 36.83 FEET TO THE POINT OF BEGINNING AND CONTAINING 41.6947 ACRES OF LAND, MORE OR LESS.

**TITLE NOTES**

ACCORDING TO THE COMMITMENT FOR TITLE INSURANCE ISSUED BY OLD REPUBLIC NATIONAL TITLE INSURANCE COMPANY (GF# 23010059T) EFFECTIVE DATE OF MARCH 01, 2023 AND ISSUED DATE OF MARCH 15, 2023, THE FOLLOWING MATTERS OF RECORD ARE ITEMIZED AS EXCEPTIONS TO TITLE COVERAGE ON SCHEDULE B THEREOF;

1). THE FOLLOWING RESTRICTIVE COVENANTS OF RECORD ITEMIZED BELOW (WE MUST EITHER INSERT SPECIFIC RECORDING DATA OR DELETE THIS EXCEPTION) DOCUMENT(S) RECORDED IN VOLUME 1004, PAGE 848 OF THE DEED RECORDS, COLLIN COUNTY, TEXAS; AS AFFECTED BY VOLUME 1110, PAGE 685 OF THE DEED RECORDS, COLLIN COUNTY, TEXAS; AND VOLUME 2643, PAGE 93 OF THE DEED RECORDS, COLLIN COUNTY, TEXAS.

10(o). ELECTRIC TRANSMISSION AND DISTRIBUTION LINES EASEMENT AND INCIDENTAL RIGHTS THERETO, GRANTED TO DENTON COUNTY ELECTRIC COOPERATIVE, INC., A CORPORATION, DATED APRIL 27, 1951, FILED MARCH 20, 1953, RECORDED IN VOLUME 467, PAGE 277, OF THE DEED RECORDS OF COLLIN COUNTY, TEXAS; AS AFFECTED BY THAT CERTAIN AGREEMENT DEFINING AREA EMBRACED WITHIN EASEMENTS OF DENTON COUNTY ELECTRIC COOPERATIVE, INC. FILED MAY 13, 1980, RECORDED IN VOLUME 1262, PAGE 312 OF THE OFFICIAL RECORDS OF COLLIN COUNTY, TEXAS; AND AS AFFECTED BY THAT CERTAIN AGREEMENT DEFINING AREA EMBRACED WITHIN EASEMENTS OF DENTON COUNTY ELECTRIC COOPERATIVE, INC., FILED MARCH 4, 1998, RECORDED IN VOLUME 4114, PAGE 55 OF THE OFFICIAL RECORDS OF COLLIN COUNTY, TEXAS (SURVEYOR'S NOTE: COULD NOT PLOT FROM DESCRIPTION CONTAINED IN DOCUMENT, BLANKET IN NATURE)

10(f). ELECTRIC TRANSMISSION AND DISTRIBUTION LINES EASEMENT AND INCIDENTAL RIGHTS THERETO, GRANTED TO DENTON COUNTY ELECTRIC COOPERATIVE, INC., A CORPORATION, DATED JUNE 2, 1938, FILED MARCH 20, 1953, RECORDED IN VOLUME 467, PAGE 283, OF THE DEED RECORDS OF COLLIN COUNTY, TEXAS; AS AFFECTED BY THAT CERTAIN AGREEMENT DEFINING AREA EMBRACED WITHIN EASEMENTS OF DENTON COUNTY ELECTRIC COOPERATIVE, INC., FILED MARCH 4, 1998, RECORDED IN VOLUME 4114, PAGE 55 OF THE OFFICIAL RECORDS OF COLLIN COUNTY, TEXAS (SURVEYOR'S NOTE: COULD NOT PLOT FROM DESCRIPTION CONTAINED IN DOCUMENT, BLANKET IN NATURE)

10(g). ELECTRIC TRANSMISSION AND DISTRIBUTION LINES EASEMENT AND INCIDENTAL RIGHTS THERETO, GRANTED TO DENTON COUNTY ELECTRIC COOPERATIVE, INC., A CORPORATION, DATED APRIL 3, 1941, FILED MARCH 20, 1953, RECORDED IN VOLUME 467, PAGE 294, OF THE DEED RECORDS OF COLLIN COUNTY, TEXAS; AS AFFECTED BY THAT CERTAIN AGREEMENT DEFINING AREA EMBRACED WITHIN EASEMENTS OF DENTON COUNTY ELECTRIC COOPERATIVE, INC., FILED MAY 13, 1980, RECORDED IN VOLUME 1262, PAGE 312 OF THE OFFICIAL RECORDS OF COLLIN COUNTY, TEXAS; AND AS AFFECTED BY THAT CERTAIN AGREEMENT DEFINING AREA EMBRACED WITHIN EASEMENTS OF DENTON COUNTY ELECTRIC COOPERATIVE, INC., FILED MARCH 4, 1998, RECORDED IN VOLUME 4114, PAGE 55 OF THE OFFICIAL RECORDS OF COLLIN COUNTY, TEXAS (SURVEYOR'S NOTE: COULD NOT PLOT FROM DESCRIPTION CONTAINED IN DOCUMENT, BLANKET IN NATURE)

10(h). ELECTRIC TRANSMISSION AND DISTRIBUTION LINES EASEMENT AND INCIDENTAL RIGHTS THERETO, GRANTED TO DENTON COUNTY ELECTRIC COOPERATIVE, INC., A CORPORATION, DATED JULY 29, 1949, FILED MARCH 20, 1953, RECORDED IN VOLUME 467, PAGE 313, OF THE DEED RECORDS OF COLLIN COUNTY, TEXAS; AS AFFECTED BY THAT CERTAIN AGREEMENT DEFINING AREA EMBRACED WITHIN EASEMENTS OF DENTON COUNTY ELECTRIC COOPERATIVE, INC., FILED MAY 13, 1980, RECORDED IN VOLUME 1262, PAGE 312 OF THE OFFICIAL RECORDS OF COLLIN COUNTY, TEXAS; AND AS AFFECTED BY THAT CERTAIN AGREEMENT DEFINING AREA EMBRACED WITHIN EASEMENTS OF DENTON COUNTY ELECTRIC COOPERATIVE, INC., FILED MARCH 4, 1998, RECORDED IN VOLUME 4114, PAGE 55 OF THE OFFICIAL RECORDS OF COLLIN COUNTY, TEXAS (SURVEYOR'S NOTE: COULD NOT PLOT FROM DESCRIPTION CONTAINED IN DOCUMENT, BLANKET IN NATURE)

10(i). ELECTRIC TRANSMISSION AND DISTRIBUTION LINES EASEMENT AND INCIDENTAL RIGHTS THERETO, GRANTED TO DENTON COUNTY ELECTRIC COOPERATIVE, INC., A CORPORATION, DATED APRIL 25, 1938, FILED MARCH 25, 1953, RECORDED IN VOLUME 468, PAGE 227, OF THE DEED RECORDS OF COLLIN COUNTY, TEXAS; AND AS AFFECTED BY THAT CERTAIN AGREEMENT DEFINING AREA EMBRACED WITHIN EASEMENTS OF DENTON COUNTY ELECTRIC COOPERATIVE, INC., FILED MAY 13, 1980, RECORDED IN VOLUME 1262, PAGE 312 OF THE OFFICIAL RECORDS OF COLLIN COUNTY, TEXAS; AND AS AFFECTED BY THAT CERTAIN AGREEMENT DEFINING AREA EMBRACED WITHIN EASEMENTS OF DENTON COUNTY ELECTRIC COOPERATIVE, INC., FILED MARCH 4, 1998, RECORDED IN VOLUME 4114, PAGE 55 OF THE OFFICIAL RECORDS OF COLLIN COUNTY, TEXAS (SURVEYOR'S NOTE: COULD NOT PLOT FROM DESCRIPTION CONTAINED IN DOCUMENT, BLANKET IN NATURE)

10(j). 10 FOOT WIDE WATER PIPE LINE FACILITIES EASEMENT AND INCIDENTAL RIGHTS THERETO, GRANTED TO LEBANON WATER SUPPLY CORPORATION, DATED FEBRUARY 5, 1966, FILED FEBRUARY 28, 1966, RECORDED IN VOLUME 669, PAGE 268, OF THE DEED RECORDS OF COLLIN COUNTY, TEXAS (SURVEYOR'S NOTE: COULD NOT PLOT FROM DESCRIPTION CONTAINED IN DOCUMENT, BLANKET IN NATURE)

10(k). 10 FOOT WIDE WATER PIPE LINE FACILITIES EASEMENT AND INCIDENTAL RIGHTS THERETO, GRANTED TO LEBANON WATER SUPPLY CORPORATION, DATED FEBRUARY 2, 1966, FILED FEBRUARY 28, 1966, RECORDED IN VOLUME 669, PAGE 290, OF THE DEED RECORDS OF COLLIN COUNTY, TEXAS; AND AS AFFECTED BY THAT CERTAIN ASSIGNMENT OF RIGHT-OF-WAY EASEMENTS, FILED SEPTEMBER 20, 1988, RECORDED IN VOLUME 2919, PAGE 214 OF THE OFFICIAL RECORDS OF COLLIN COUNTY, TEXAS (SURVEYOR'S NOTE: COULD NOT PLOT FROM DESCRIPTION CONTAINED IN DOCUMENT, BLANKET IN NATURE)

**TITLE NOTES (CONTINUED)**

10(l). THE FOLLOWING EXCEPTIONS AFFECT TRACT 1:  
1. UNDERGROUND ELECTRIC SUPPLY AND COMMUNICATIONS FACILITIES EASEMENT AND INCIDENTAL RIGHTS THERETO, GRANTED TO ONCOR ELECTRIC DELIVERY COMPANY LLC, A DELAWARE LIMITED LIABILITY COMPANY, DATED AUGUST 7, 2012, FILED DECEMBER 20, 2012, RECORDED IN INSTRUMENT NO. 20121220001622010, OF THE OFFICIAL RECORDS OF COLLIN COUNTY, TEXAS (SURVEYOR'S NOTE: LOCATED ON SUBJECT PROPERTY, AS SHOWN ON SURVEY)

2. TERMS, CONDITIONS AND STIPULATIONS CONTAINED IN SANITARY SEWER EASEMENT AGREEMENT, EXECUTED BY AND BETWEEN SKYBOX LEGACY I, LLP, A TEXAS LIMITED PARTNERSHIP, AND BC FAMILY PARTNERS LP, A TEXAS LIMITED PARTNERSHIP, DATED MARCH 7, 2016, FILED MARCH 8, 2016, RECORDED IN INSTRUMENT NO. 20160308000274550 OF THE OFFICIAL RECORDS OF COLLIN COUNTY, TEXAS; AND AS AFFECTED BY THAT CERTAIN AMENDED AND RESTATED SANITARY SEWER EASEMENT AGREEMENT, FILED MARCH 28, 2016, RECORDED IN INSTRUMENT NO. 20160328000354770 OF THE OFFICIAL RECORDS OF COLLIN COUNTY, TEXAS (SURVEYOR'S NOTE: LOCATED ON SUBJECT PROPERTY, AS SHOWN ON SURVEY)

10(m). THE FOLLOWING EXCEPTIONS AFFECT TRACT 2:  
1. UNDERGROUND ELECTRIC SUPPLY AND COMMUNICATIONS LINES EASEMENT AND INCIDENTAL RIGHTS THERETO, GRANTED TO ONCOR ELECTRIC DELIVERY COMPANY LLC, A DELAWARE LIMITED LIABILITY COMPANY, DATED MARCH 18, 2015, FILED MARCH 25, 2015, RECORDED IN INSTRUMENT NO. 20150325000328590, OF THE OFFICIAL RECORDS OF COLLIN COUNTY, TEXAS (SURVEYOR'S NOTE: LOCATED ON SUBJECT PROPERTY, AS SHOWN ON SURVEY)

2. UNDERGROUND DRAINAGE FACILITIES EASEMENT AND INCIDENTAL RIGHTS THERETO, GRANTED TO THE CITY OF PLANO, A HOME RULE MUNICIPAL CORPORATION, DATED MARCH 21, 2016, FILED MARCH 22, 2016, RECORDED IN INSTRUMENT NO. 20160322000334910, OF THE OFFICIAL RECORDS OF COLLIN COUNTY, TEXAS (SURVEYOR'S NOTE: LOCATED ON SUBJECT PROPERTY, AS SHOWN ON SURVEY)

3. ELECTRIC FACILITIES EASEMENT AND INCIDENTAL RIGHTS THERETO, GRANTED TO DENTON COUNTY ELECTRIC COOPERATIVE, INC., D/B/A COSERV ELECTRIC, DATED DECEMBER 8, 2020, FILED DECEMBER 9, 2020, RECORDED IN INSTRUMENT NO. 20201209002216630, OF THE OFFICIAL RECORDS OF COLLIN COUNTY, TEXAS (SURVEYOR'S NOTE: LOCATED ON SUBJECT PROPERTY, AS SHOWN ON SURVEY)

10(n). THE FOLLOWING EXCEPTIONS AFFECT TRACT 3:  
1. DRAINAGE FACILITIES EASEMENT AND INCIDENTAL RIGHTS THERETO, GRANTED TO THE CITY OF PLANO, A HOME RULE MUNICIPAL CORPORATION, DATED NOVEMBER 8, 2002, FILED DECEMBER 18, 2002, RECORDED IN VOLUME 5319, PAGE 355, OF THE OFFICIAL RECORDS OF COLLIN COUNTY, TEXAS (SURVEYOR'S NOTE: LOCATED ON SUBJECT PROPERTY, AS SHOWN ON SURVEY)

2. THE FOLLOWING, ALL ACCORDING TO PLAT RECORDED IN VOLUME 2016, PAGE 7, OF THE PLAT RECORDS OF COLLIN COUNTY, TEXAS: I. 24 FOOT FIRELANE, ACCESS & UTILITY EASEMENT LOCATED OVER AND ACROSS THE NORTH PORTION OF THE PROPERTY; II. 10 FOOT PROPOSED ONCOR ELECTRIC DELIVERY COMPANY EASEMENT LOCATED ALONG THE SOUTH PORTION OF THE PROPERTY; AND III. 10 FOOT PROPOSED FIBER OPTIC EASEMENT LOCATED ALONG THE SOUTH PORTION OF THE PROPERTY (SURVEYOR'S NOTE: LOCATED ON SUBJECT PROPERTY, AS SHOWN ON SURVEY)

3. TERMS, PROVISIONS AND CONDITIONS AS SET FORTH IN THAT CERTAIN NO-BUILD RESTRICTION AGREEMENT DATED MARCH 7, 2016, EXECUTED BY SKYBOX LEGACY I, LP, A TEXAS LIMITED PARTNERSHIP, CROOM INTERESTS, LTD., A TEXAS LIMITED PARTNERSHIP, AND BC FAMILY PARTNERS LP, A TEXAS LIMITED PARTNERSHIP, FILED MARCH 8, 2016, AND RECORDED IN CLERK'S FILE NO. 20160308000274540, REAL PROPERTY RECORDS, COLLIN COUNTY, TEXAS (SURVEYOR'S NOTE: LOCATED ON SUBJECT PROPERTY, AS SHOWN ON SURVEY)

4. 10 FOOT WIDE WATER LINE FACILITIES EASEMENT AND INCIDENTAL RIGHTS THERETO, GRANTED TO THE CITY OF PLANO, A HOME RULE MUNICIPAL CORPORATION, DATED MARCH 21, 2016, FILED MARCH 22, 2016, RECORDED IN INSTRUMENT NO. 20160322000334920, OF THE OFFICIAL RECORDS OF COLLIN COUNTY, TEXAS (SURVEYOR'S NOTE: LOCATED ON SUBJECT PROPERTY, AS SHOWN ON SURVEY)

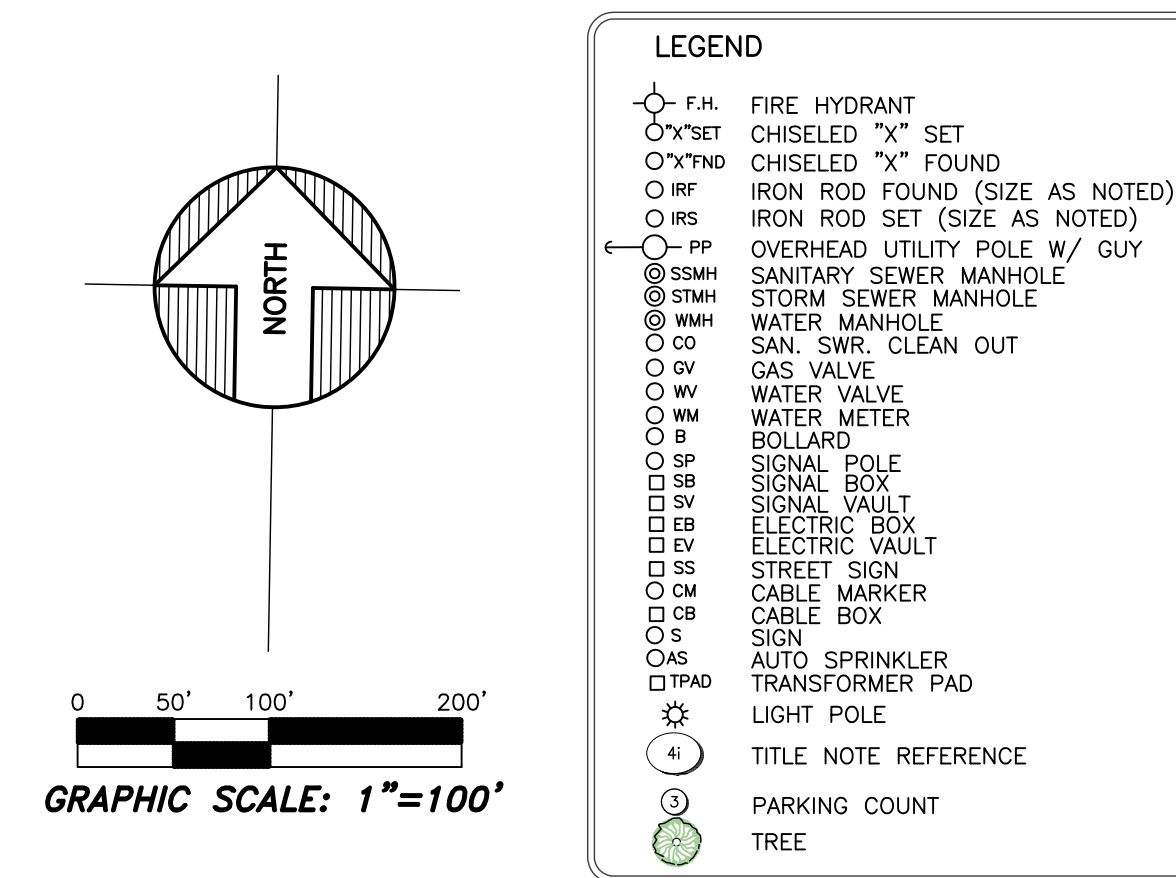
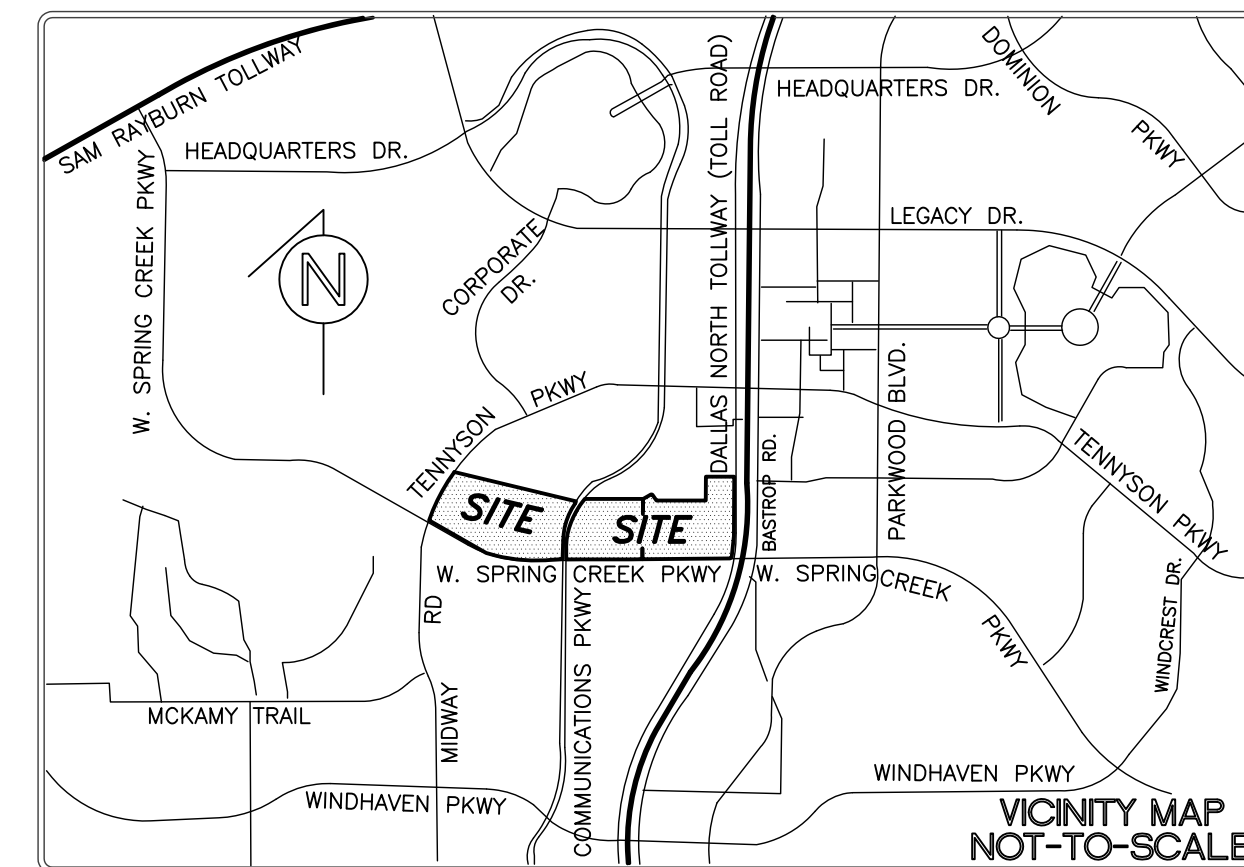

**FLOOD NOTE**  
ACCORDING TO THE FEDERAL EMERGENCY MANAGEMENT AGENCY (FEMA) - NATIONAL FLOOD INSURANCE PROGRAM (NFIP) FLOOD INSURANCE RATE MAP (FIRM) - FOR THE COLLIN COUNTY, TEXAS AND INCORPORATED AREAS - MAP NO. 4805C0355K, MAP REVISED, JUNE 07, 2017, THE PROPERTY SHOWN HEREON LIES IN ZONE "X" (OTHER AREAS).  
ZONE "X"(OTHER AREAS) IS DEFINED AS "AREAS DETERMINED TO BE OUTSIDE THE 0.2% ANNUAL CHANCE FLOODPLAIN".  
THIS FLOOD STATEMENT DOES NOT IMPLY THAT THE PROPERTY AND/OR THE STRUCTURE THEREON WILL BE FREE FROM FLOODING OR FLOOD DAMAGE. ON RARE OCCASIONS, GREATER FLOODS CAN AND WILL OCCUR AND FLOOD HEIGHTS MAY BE INCREASED BY MAN-MADE OR NATURAL CAUSES. THIS FLOOD STATEMENT SHALL NOT CREATE LIABILITY ON THE PART OF THE SURVEYOR.

**CERTIFICATION**  
TO: CLEARSTONE PARTNERS, LLC, A TEXAS LIMITED LIABILITY COMPANY; BC FAMILY PARTNERS, LP, A TEXAS LIMITED LIABILITY PARTNERSHIP; CROOM INTERESTS, LTD, A TEXAS LIMITED LIABILITY PARTNERSHIP; AND OLD REPUBLIC NATIONAL TITLE INSURANCE COMPANY (GF NO. 23010059T):  
THIS IS TO CERTIFY THAT THIS MAP OR PLAT AND THE SURVEY ON WHICH IT IS BASED WERE MADE IN ACCORDANCE WITH THE 2021 MINIMUM STANDARD DETAIL REQUIREMENTS FOR ALTA/NSPS LAND TITLE SURVEYS, JOINTLY ESTABLISHED AND ADOPTED BY ALTA AND NSPS, AND INCLUDES ITEMS 1, 2, 3, 4, 7(a), 7(b), 7(c), 8, 9, 11 (VISIBLE UTILITIES ONLY), 13, 18 & 19 OF TABLE A THEREOF.  
**PRELIMINARY / FOR REVIEW**  
DAVID PETREE  
REGISTERED PROFESSIONAL  
LAND SURVEYOR NO. 1890

**LAND TITLE SURVEY**  
**BACCUS/CROOM PROPERTY**  
**41.6947 ACRE PARCEL**  
**COLLIN COUNTY SCHOOL LAND SURVEY NO. 150**  
**HENRY B. MILLER SURVEY - ABSTRACT NO. 614**  
**CITY OF PLANO, COLLIN COUNTY, TEXAS**  
SHEET 2 OF 2  
DATE: APRIL 18, 2023  
SCALE: 1"=100  
DRPETREE@BLUESKYSURVEYING.COM  
TPLS REGISTRATION NO. 10105700  
TollwaySpringCreekCommunications