

VESTING TENTATIVE TRACT MAP TR-3073

BEING A SEVEN LOT SUBDIVISION OF A PORTION OF RANCHO CORRAL DE PIEDRA,
 COUNTY OF SAN LUIS OBISPO, STATE OF CALIFORNIA,
 AS DESCRIBED ON RECORD OF SURVEY RS 13-006, BOOK 107 PAGE 60
 APN 047-181-001

SLOPE CALCULATION-CONTOUR MEAS. METHOD					
LOT NUMBER	CONSTANT	"I" (FEET)	"L" (FEET)	"/"A" (ACRES)	AV. SLOPE (%)
1	0.00229	10	3798	5.07	17.2
2	0.00229	10	3190	5.08	14.4
3	0.00229	10	3331	5.04	15.2
4	0.00229	10	2896	5.35	12.3
5	0.00229	10	3432	5.60	14.1
6	0.00229	10	5113	5.43	21.5
7	0.00229	10	2732	5.13	12.2

LOT SUMMARY					
LOT NUMBER	TOTAL LOT AREA (GROSS ACRES)	TOTAL LOT AREA MINUS OPEN SPACE (GROSS ACRES)	TOTAL LOT AREA MINUS OPEN SPACE AND EASEMENTS (NET ACRES)	AV. SLOPE	LENGTH/WIDTH
1	5.07	0.79	0.59	17.2	0.6:1
2	5.08	2.64	2.21	14.4	1.1:1
3	5.03	1.97	2.34	15.2	0.4:1
4	5.35	3.08	3.04	12.3	1.3:1
5	5.60	1.86	1.73	14.1	0.9:1
6	5.45	1.51	0.90	21.5	0.2:1
7	5.13	2.51	2.27	12.2	3.0:1

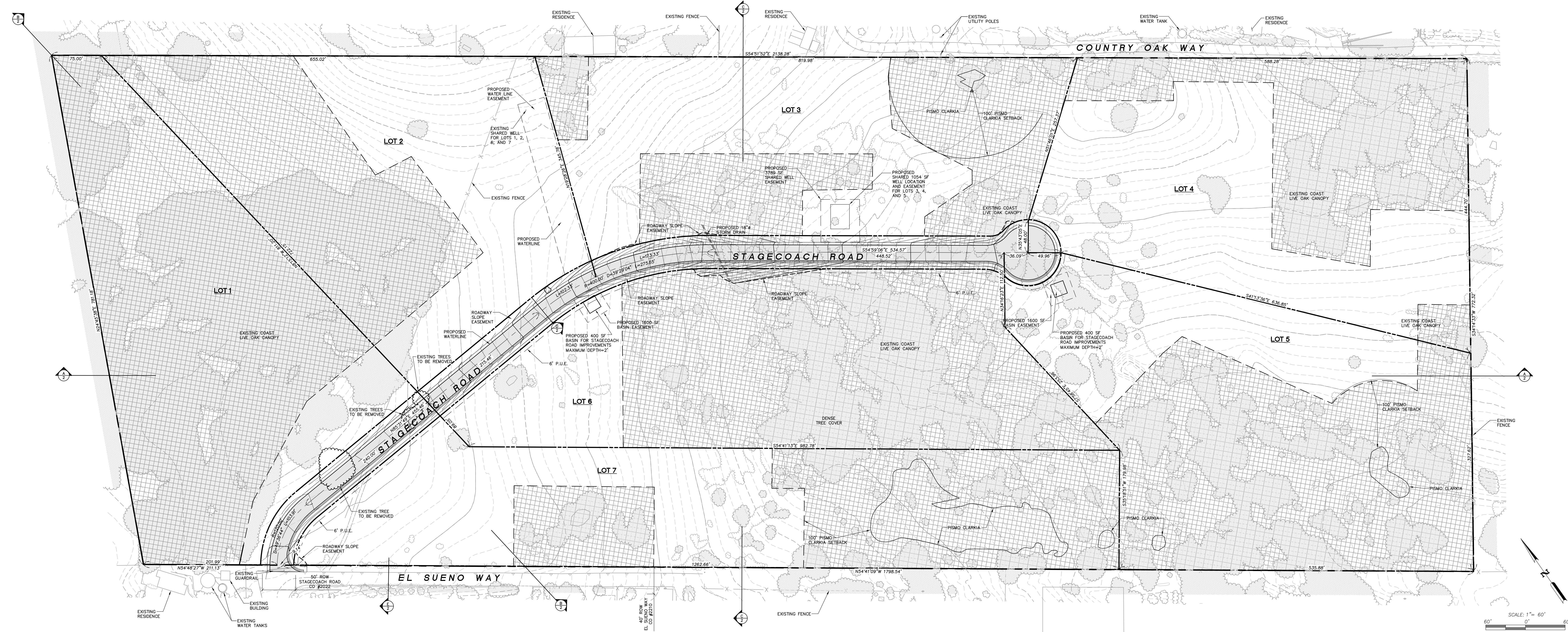

VICINITY MAP:

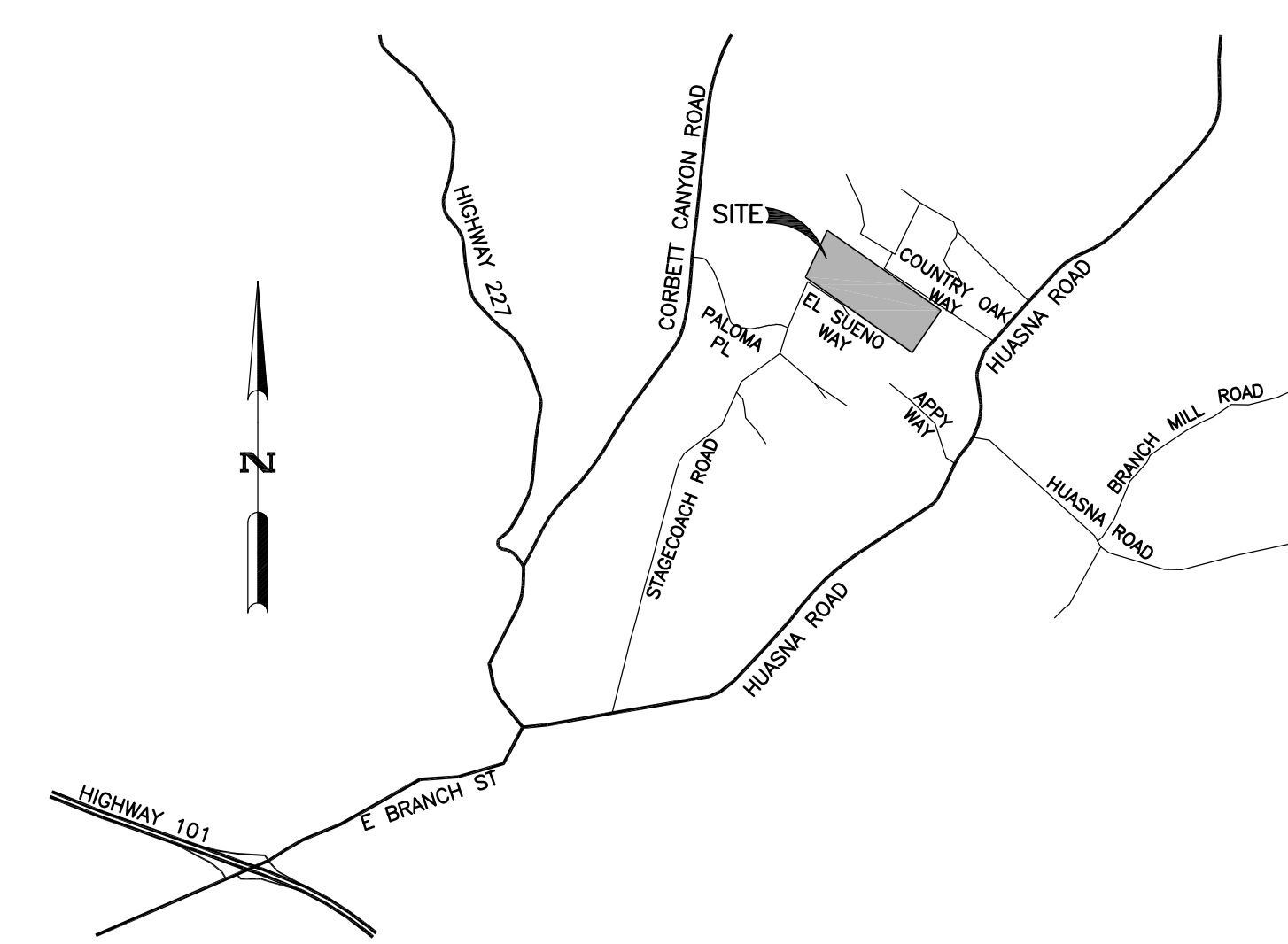

BASIS OF BEARINGS:
 THE BASIS OF BEARINGS FOR THIS SURVEY IS BASED UPON CALIFORNIA COORDINATE SYSTEM, ZONE 5, NAD 83

ASSESSOR'S PARCEL NO:
 078-181-001

REFERENCE MAPS:
 RECORD DATA PER 107 RS 60

OWNER:
 PATRICK SULLIVAN
 874 TEMPUS CIR
 ARROYO GRANDE, CA 93420

PROJECT NOTES:
 WATER SUPPLY - PROPOSED SHARED WELLS
 SEWER - INDIVIDUAL LOT ONSITE SEPTIC DISPOSAL SYSTEMS
 STORMWATER - INDIVIDUAL LOT RETENTION BASINS
 GRADING QUANTITIES - CUT - FILL
 AREA OF DISTURBANCE FOR TRACT IMPROVEMENTS-94368 SQ. FT.

LEGEND

(832)	EXISTING CONTOUR
---	NEW CONTOURS
---	CENTERLINE
---	FLOWLINE
---	EASEMENT
---	EDGE OF PAVING
---	FENCE
---	EXISTING PROPERTY LINE
---	PROPOSED PROPERTY LINE
---	SANITARY SEWER LINES
---	WATER LINES
---	EXISTING TREES
---	EXISTING BRUSH
---	REFER TO DETAIL NUMBER ON SHEET NUMBER
---	OPEN SPACE EASEMENT

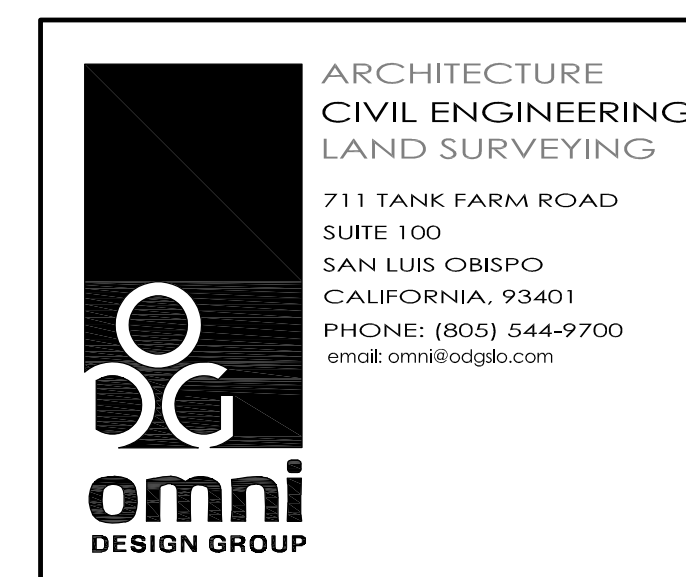

RECORD DRAWINGS

DAVID A. MARCHELL, PE C65215 Date _____

REVISIONS THIS SHEET:

OMNI DESIGN GROUP, INC
GREENVIEW ESTATES

Design/Drawn: SCH

Job No.: 1102-01

California Coordinates: DAVID A. MARCHELL, PE C65215 Date: _____

Sheet: N 606 E 1234 1 of 2

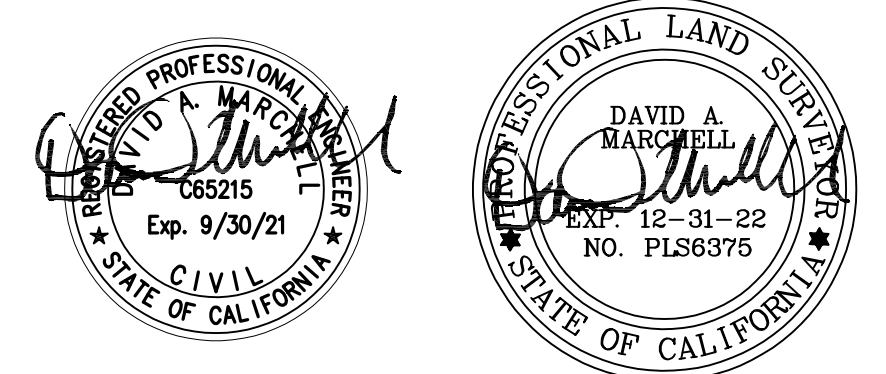

VESTING TENTATIVE TRACT MAP TR-3073

BEING A SEVEN LOT SUBDIVISION OF A PORTION OF RANCHO CORRAL DE PIEDRA,
 COUNTY OF SAN LUIS OBISPO, STATE OF CALIFORNIA,
 AS DESCRIBED ON RECORD OF SURVEY RS 13-006, BOOK 107 PAGE 60
 APN 047-181-001

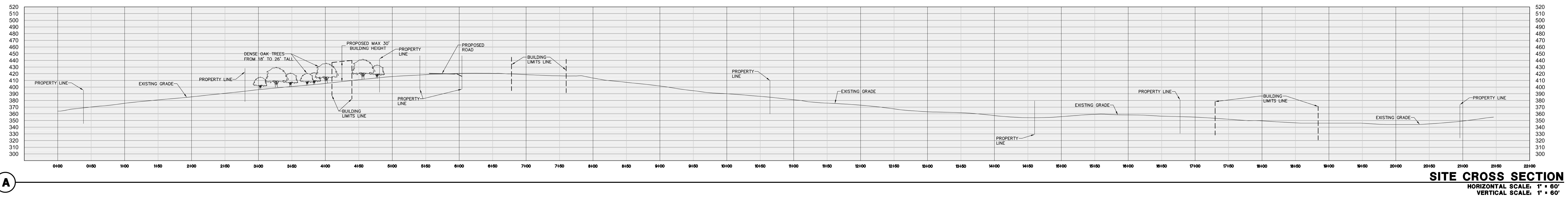

SITE CROSS SECTION
 HORIZONTAL SCALE: 1" = 60'
 VERTICAL SCALE: 1" = 60'

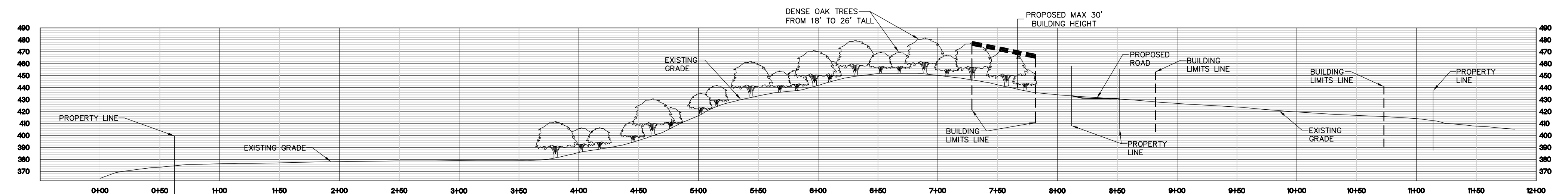

SITE CROSS SECTION
 HORIZONTAL SCALE: 1" = 60'
 VERTICAL SCALE: 1" = 60'

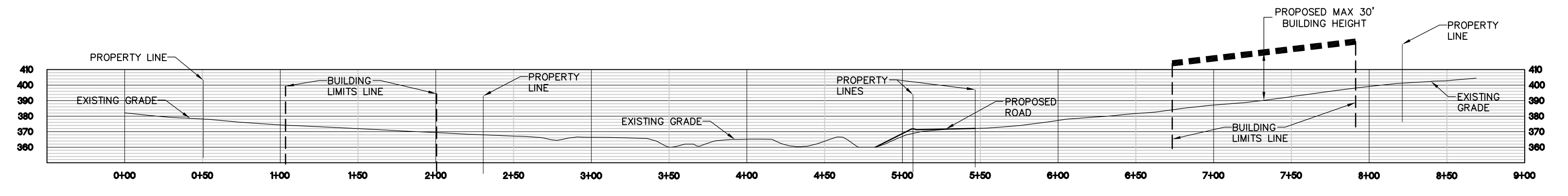

SITE CROSS SECTION
 HORIZONTAL SCALE: 1" = 60'
 VERTICAL SCALE: 1" = 60'

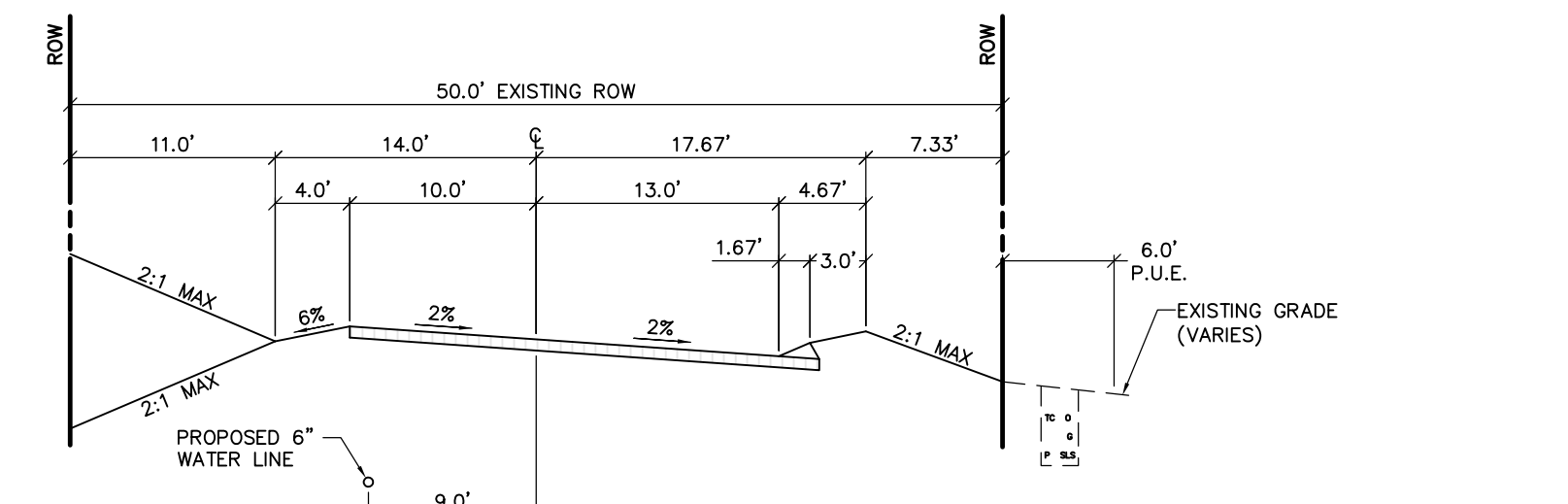

PROPOSED STAGECOACH ROAD SECTION, TYP
 HORIZONTAL SCALE: 1" = 10'
 VERTICAL SCALE: 1" = 2'

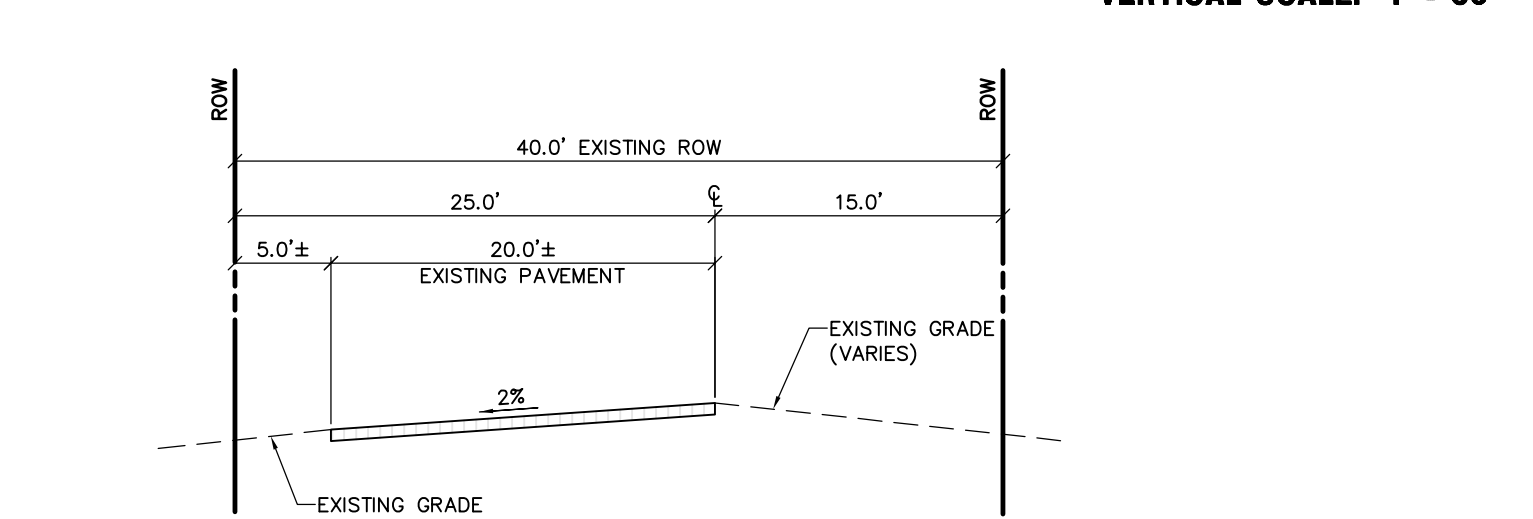

EL SUENO WAY A-1 SECTION
 HORIZONTAL SCALE: 1" = 10'
 VERTICAL SCALE: 1" = 2'

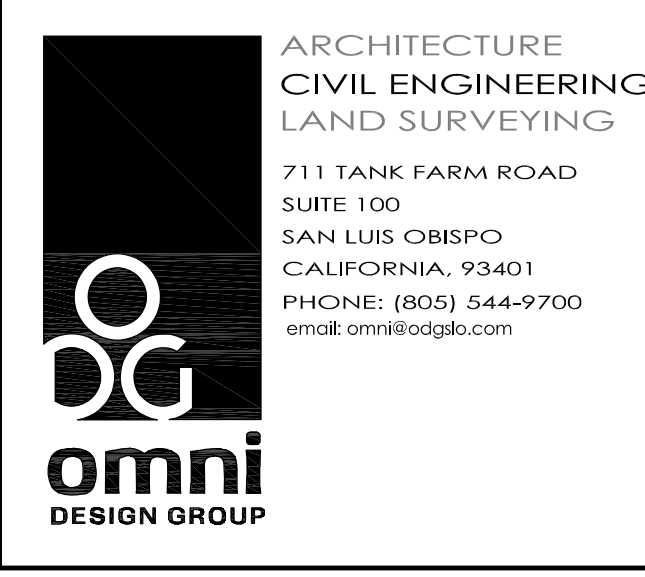
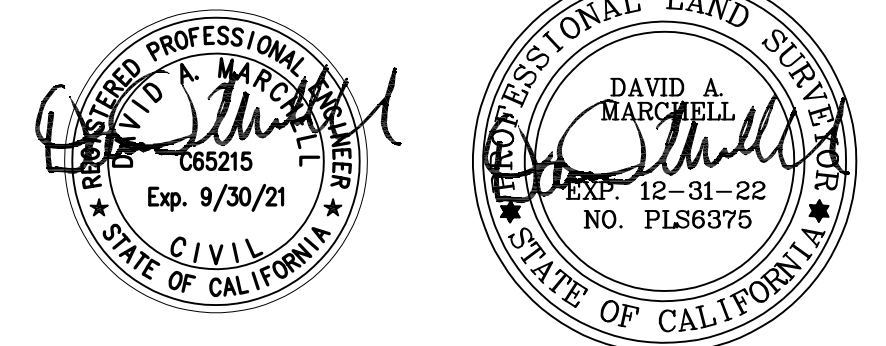

RECORD DRAWINGS	
DAVID A. MARCHELL, PE C65215	Date
REVISIONS THIS SHEET:	

OMNI DESIGN GROUP, INC	
GREENVIEW ESTATES	
Design/Drawn	SCH
Job No.	1102-01
California Coordinates	DAVID A. MARCHELL, PE C65215
N 606 E 1234	Sheet 2 of 2