

N.E. CORNER
N/2 NE/4 SE/4

LEGAL DESCRIPTION

The North Half of the Northeast Quarter of the Southeast Quarter (N/2 NE/4 SE/4), the North Half of the South Half of the Northeast Quarter of the Southeast Quarter (N/2 S/2 NE/4 SE/4) and all that part of the Northwest Quarter of the Southeast Quarter (NW/4 SE/4) lying East of the Creek Turnpike Right-of-Way, all in Section 5, Township 19 North, Range 15 East of the Indian Base and Meridian, Wagoner County, State of Oklahoma.

Contains 38.8930 acres, more or less.

CERTIFICATION

I, Kody Couch, the undersigned, a duly Registered Professional Land Surveyor, R.P.L.S.#2032, in the State of Oklahoma do hereby certify that a careful and accurate survey of the described property was made under my supervision to the best of my knowledge and the accompanying plat is a true and accurate representation of the same. This plat survey meets the Oklahoma Minimum Standards for the practice of Land Surveying as adopted by the Oklahoma State Board of Registration for Professional Engineers and Land Surveyors.

The word certify or certificate as shown and used hereon means an expression of professional opinion regarding facts of the survey and does not constitute a warranty of guarantee, expressed or implied.

Witness my hand and seal this 20th day of May, 2024.

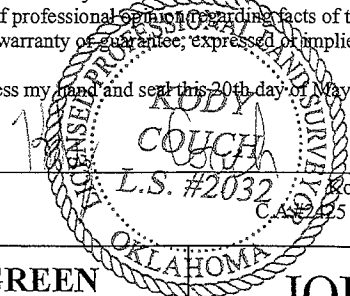

Kody Couch, R.P.L.S. #2032
C.A.#2425 6/30/24 Copyright 2024

- ▣- SET 3/8" I.P. W/ L.S. #2032 CAP
- FOUND MAGNAIL
- ⊙- FOUND ALUMINUM MONUMENT
- △- SET MAGNAIL W/L.S. #2032 WASHER

NO EASEMENTS WERE SUPPLIED, RESEARCHED, OR ADDRESSED AS PART OF THIS SURVEY AND PLAT.

BASIS OF BEARING IS S1°53'13"E ALONG THE EAST LINE OF SAID SE/4.

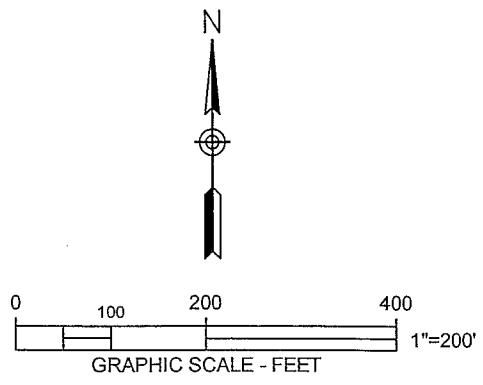

GREEN COUNTRY SURVEYING 207 SOUTH ADAIR STREET P.O. BOX 445 PRYOR, OKLAHOMA 74362 918-825-6575 OFFICE 918-825-3606 FAX		JOHNSON PROPERTY		
		SURVEY PLAT		
DRAWN KRC	CHECKED KRC	DATE OF FIELD WORK 5/16/2024	SCALE 1"=200'	CRD. FILE - GP312015 DWG FILE - JHNSN-B5