

Office Building For Lease

// **201 W NORTH RIVER DR**

Spokane, WA 99201

LEASING INCENTIVE

4% COMMISSION TO COOPERATING BROKER
PLUS \$1.00 PER SQUARE FOOT BONUS FOR
NEW LEASES THREE YEARS OR LONGER



Presented by:

BOB SPOONER

COMMERCIAL & LEASING MANAGER
509.999.1959
BSPOONER@G-B.COM

DAVID PETERSON

EXECUTIVE V.P. & COO
509.459.6113
DPETERSON@G-B.COM



// PROPERTY SUMMARY



PROPERTY DESCRIPTION

Located on the North Bank of the Spokane River, this office building consists of beautiful class A office spaces with expansive views of Spokane and Riverfront Park.

PROPERTY HIGHLIGHTS

- Leasing incentive: 4% commission to cooperating broker plus \$1.00 PSF bonus for new leases three years or longer
- 24 Hour Tenant Access
- On-Site Maintenance Staff
- Tenant Controlled HVAC
- Dedicated Loading Area for Deliveries
- Cleaning Service
- Parking Garage
- Direct Access to Centennial Trail
- Close Proximity to Dining, Shopping, and Recreation

SPACES	LEASE RATE	SPACE SIZE
Suite 605	\$30.00 SF/yr	4,446 SF

DEMOGRAPHICS	1 MILE	3 MILES	5 MILES
Total Households	4,832	54,071	114,237
Total Population	10,623	125,069	266,312
Average HH Income	\$33,409	\$49,046	\$51,407

Presented by:

BOB SPOONER
COMMERCIAL & LEASING MANAGER
509.999.1959
BSPOONER@G-B.COM

DAVID PETERSON
EXECUTIVE V.P. & COO
509.459.6113
DPETERSON@G-B.COM



// FLOOR PLANS

Suite 605 - 4,446 SF

- Conference room
- Break room
- Reception and waiting room
- \$30.00 SF/yr
- Outstanding River and Park Views
- 13 Private offices

Available 1/1/2026 (possibly sooner)

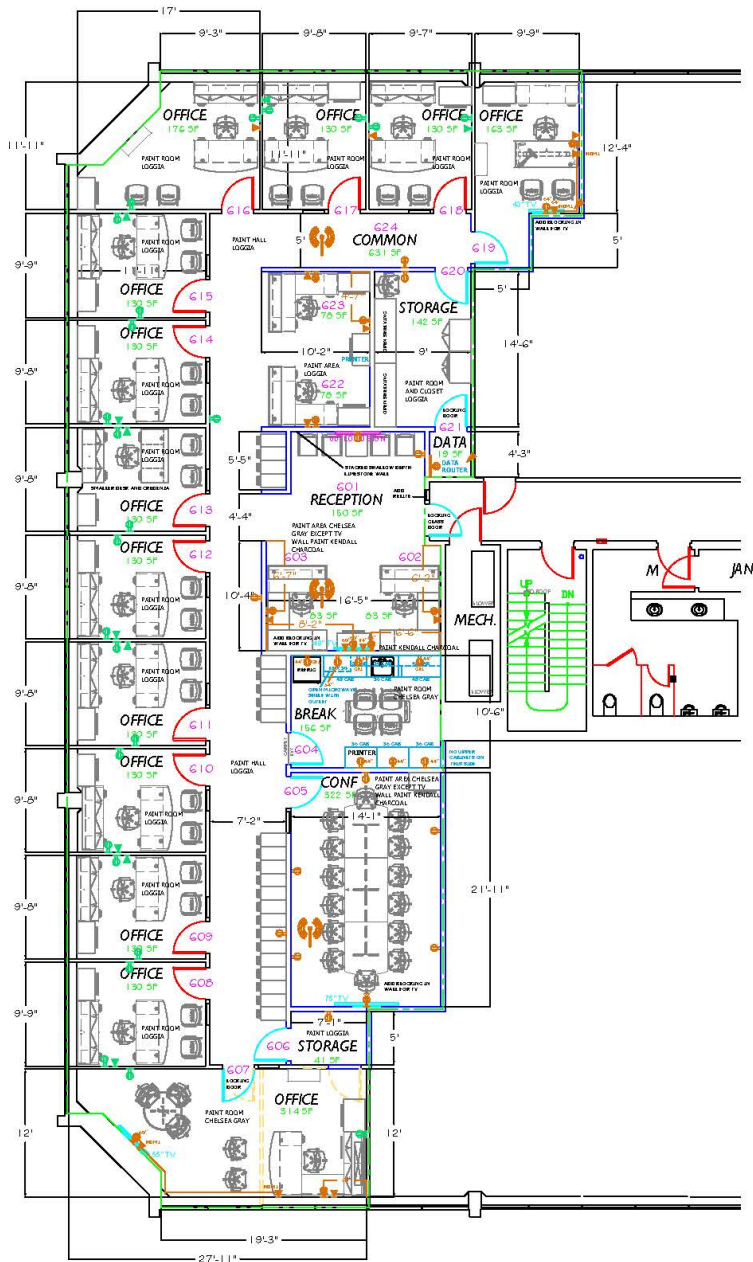

Presented by:

BOB SPOONER
COMMERCIAL & LEASING MANAGER
509.999.1959
BSPOONER@G-B.COM

DAVID PETERSON
EXECUTIVE V.P. & COO
509.459.6113
DPETERSON@G-B.COM



// RETAILER MAP



Presented by:

BOB SPOONER
COMMERCIAL & LEASING MANAGER
509.999.1959
BSPOONER@G-B.COM

DAVID PETERSON
EXECUTIVE V.P. & COO
509.459.6113
DPETERSON@G-B.COM

