



TARZANA OFFICE PLAZA





18757

*Reignite
Your Business*

CLASS A OFFICE BUILDING | **SPEC SUITES AVAILABLE**

18757 BURBANK BOULEVARD | TARZANA, CA

PROPERTY HIGHLIGHTS

-  Freeway-visible building top signage available*
-  Plentiful retail / amenities nearby
-  Subterranean parking
-  Offering excellent freeway access
-  Flexible layouts between 1,000 - 7,000 RSF
-  Window offices allow for plenty of natural light

*Building top signage is available on a long term lease over 6,500 RSF. Signage shall be at Tenant's expense and landlords review and approval.

*Premier Office Building
Located in the San Fernando Valley*

Availabilities

SUITE	RSF	AVAILABLE	DESCRIPTION	PRICE
104	1,332	NOW	2 LARGE WINDOW-LINE OFFICES, 1 INTERIOR OFFICE, KITCHENETTE WITH PLUMBING, OPEN BULLPEN	\$2.25 FSG
109	1,623	NOW	CONFERENCE ROOM OFF RECEPTION, 4 WINDOWED OFFICES, KITCHEN, SMALL RECEPTION AREA	\$2.25 FSG
114	3,169	NOW	MIX OF 9 WINDOWED AND INTERIOR OFFICES, CONFERENCE ROOM, KITCHEN, RECEPTION AREA, BULLPEN AREA	\$2.25 FSG
210	1,435	NOW	2 WINDOWED OFFICES, INTERIOR OFFICE, CONFERENCE ROOM, RECEPTION/BULLPEN AREA	\$2.25 FSG
212	2,433	NOW	4 LARGE WINDOW-LINE OFFICES, 1 INTERIOR OFFICE, 1 CONFERENCE ROOM, ENCLOSED KITCHEN AREA, RECEPTION BAY, BULLPEN, STORAGE/IT	\$2.25 FSG
302*	6,777	NOW	7 WINDOWED OFFICES, CONFERENCE ROOM, LARGE BULLPEN, KITCHEN	\$2.35 FSG
306*	1,463	NOW	3 WINDOWED OFFICES, INTERIOR OFFICE AND BULLPEN	TBD
307*	958	8/1/24	3 PRIVATE OFFICES, KITCHENETTE WITH SINK AND PLUMBING, SMALL OPEN AREA FOR WORKSTATIONS AND/OR RECEPTION	TBD

*SUITES 302, 306 & 307 ARE CONTIGUOUS AND CAN BE COMBINED FOR 9,198 RSF.

Term Negotiable

Rent \$2.25 FSG

Parking 3/1,000

Parking Rates

\$75 Single Unreserved,
\$65 Tandem Reserved
(Per Stall), \$150 Reserved

FLOOR PLAN

First Floor



SUITE RSF

■	104	1,332
■	109	1,623
■	114	3,169

FLOOR PLAN

Suite 104 - 1,332 RSF
As-Built

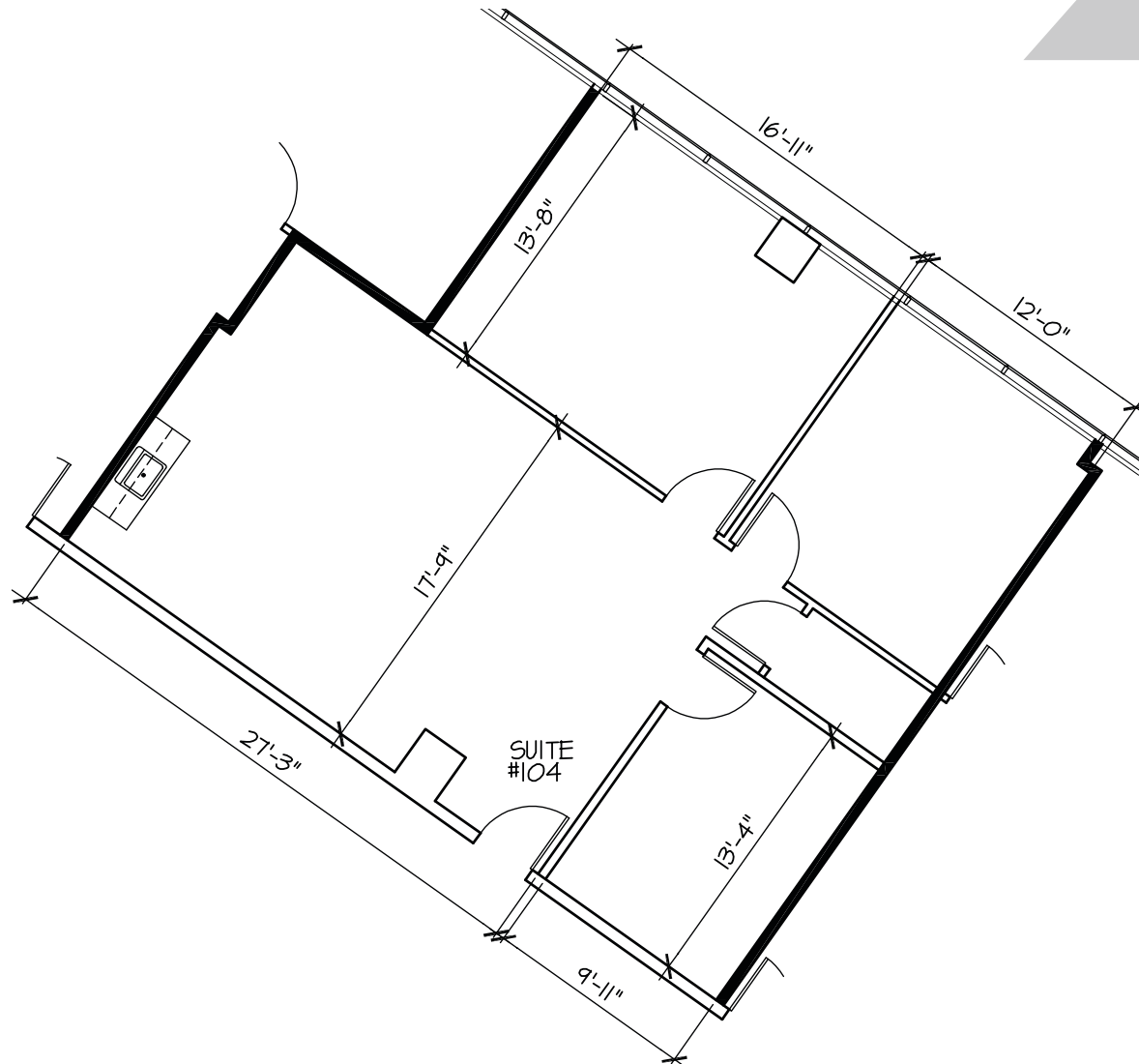

SUITE HIGHLIGHTS:

- Two (2) Large Window-Line Offices
- One (1) Interior Office
- Kitchenette with Plumbing
- Open Bullpen

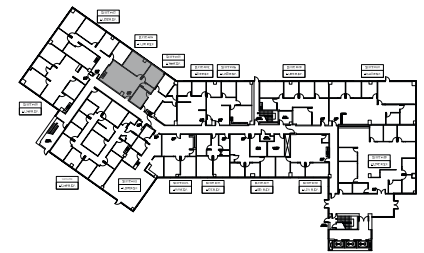

FLOOR PLAN

Suite 109 - 1,623 RSF

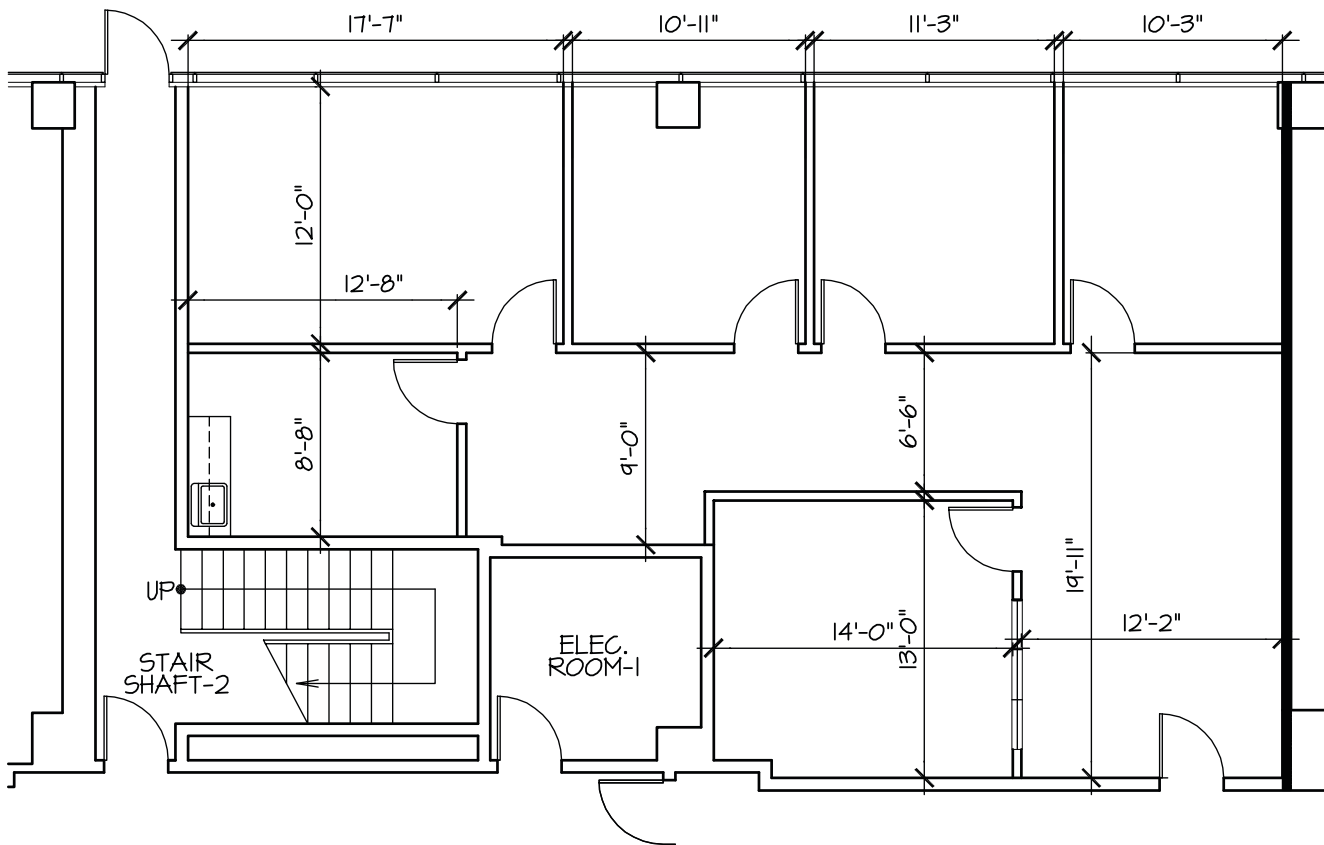

SUITE HIGHLIGHTS:

- Conference Room Off Reception
- Four (4) Windowed Offices
- Kitchen
- Small Reception Area

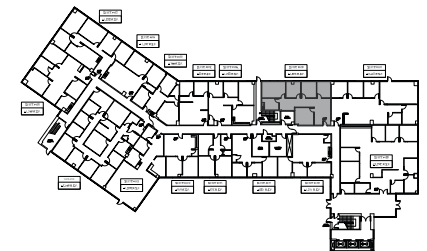

FLOOR PLAN

Suite 114 - 3,169 RSF

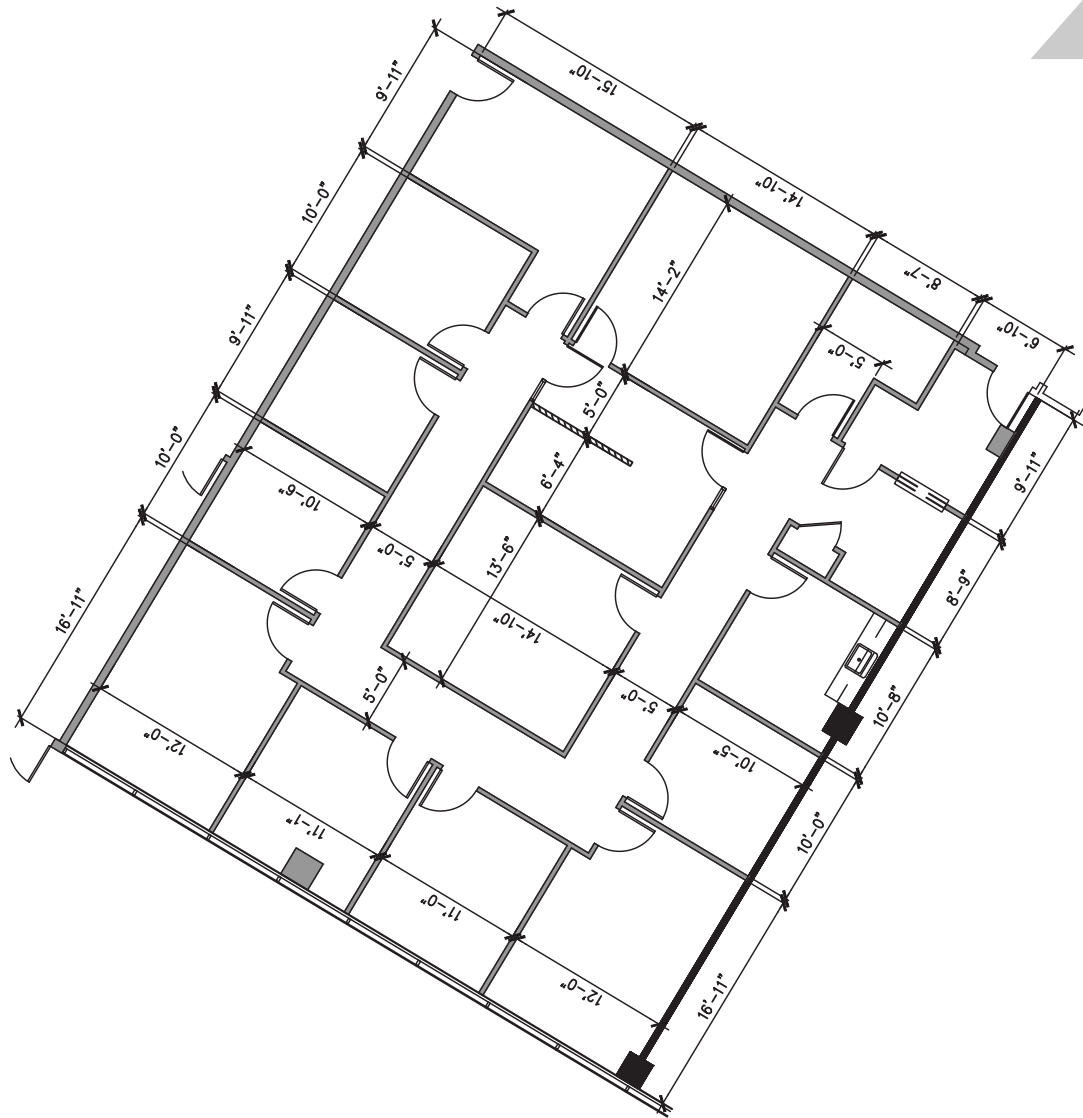

SUITE HIGHLIGHTS:

- Reception Area
- Perimeter Offices
- Kitchen
- Bullpen Area

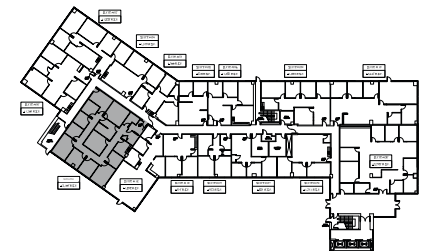

FLOOR PLAN

Second Floor

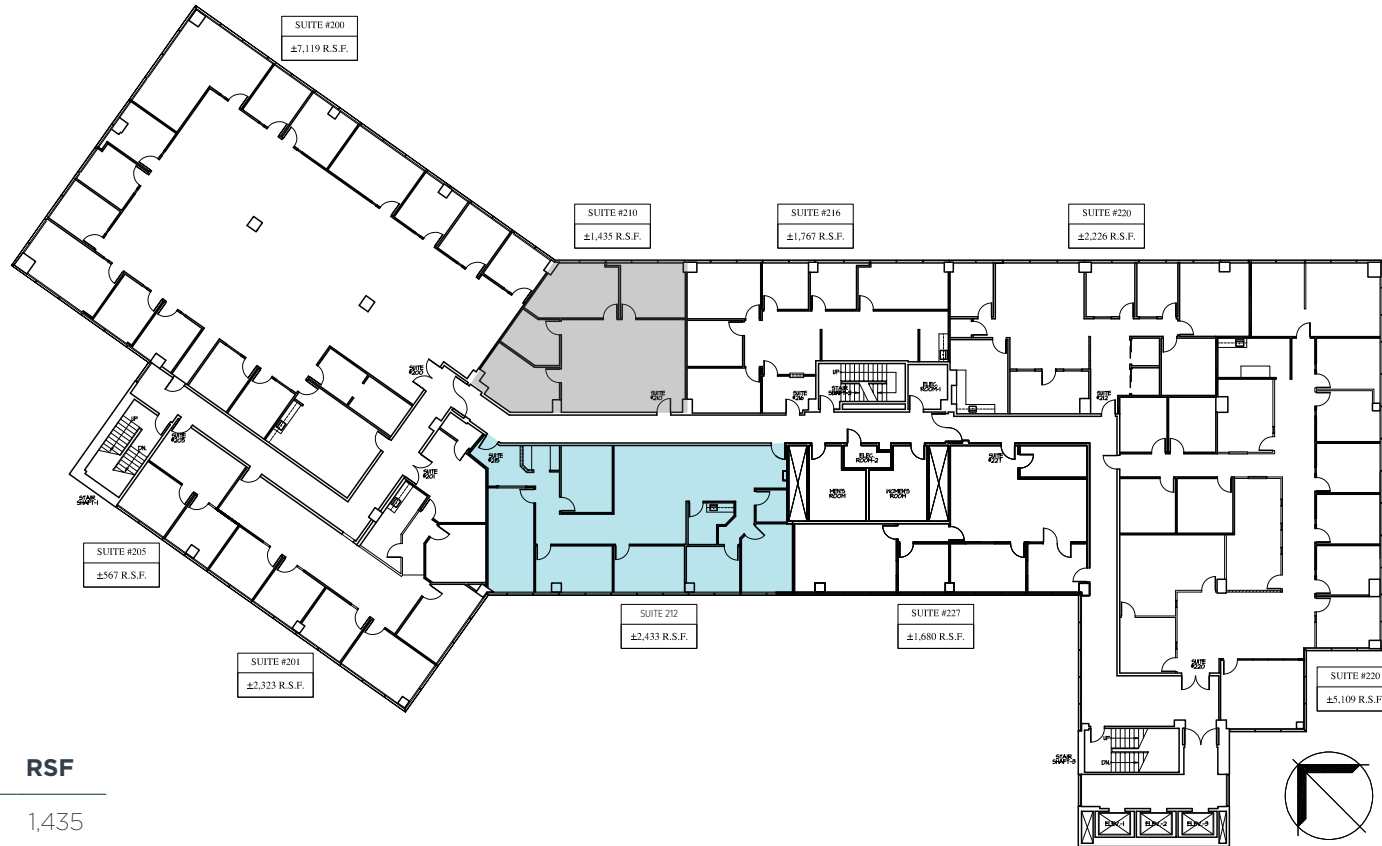

SUITE RSF

■	210	1,435
■	212	2,433

FLOOR PLAN

Suite 210 - 1,435 RSF

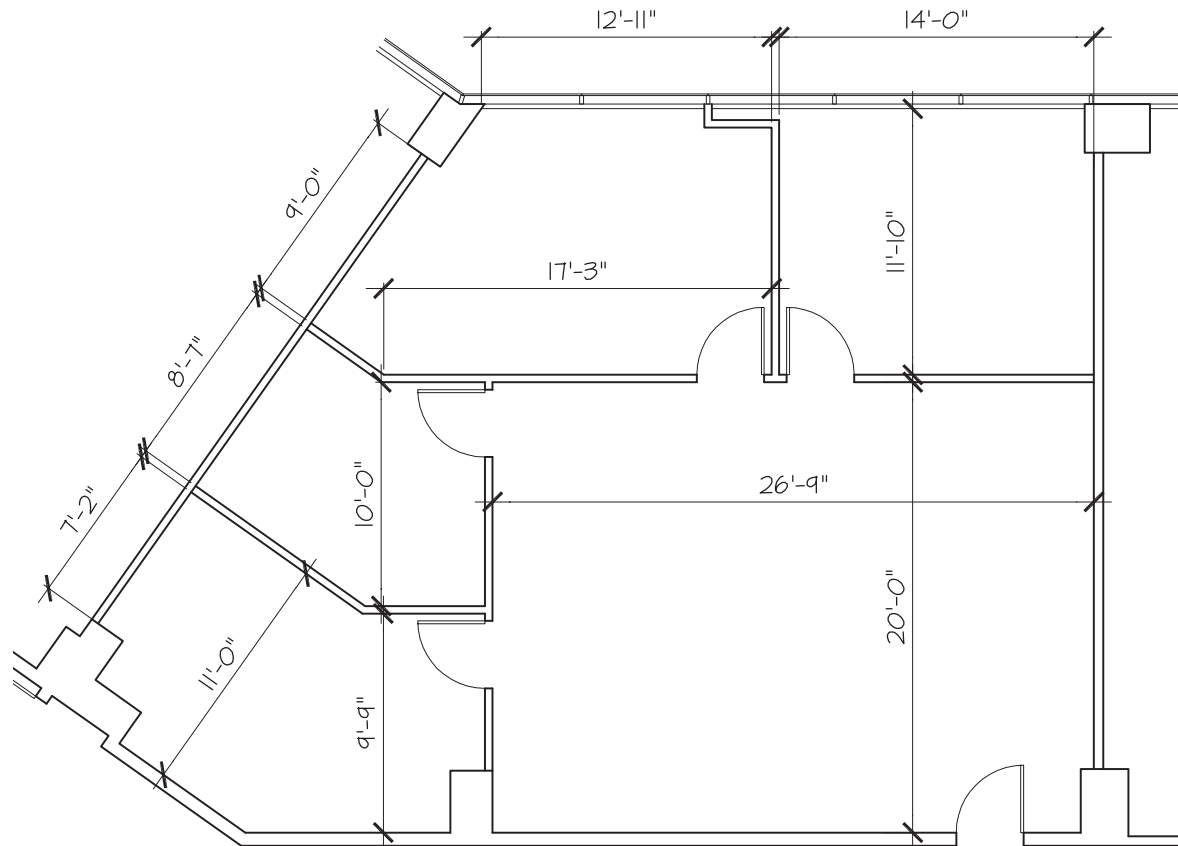

SUITE HIGHLIGHTS:

- Two (2) Windowed Offices
- Interior Storage
- Interior Office
- Bullpen/Reception Area

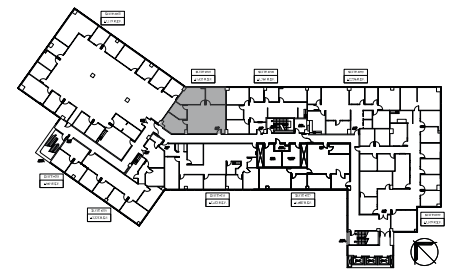

FLOOR PLAN

Suite 212 - 2,433 RSF

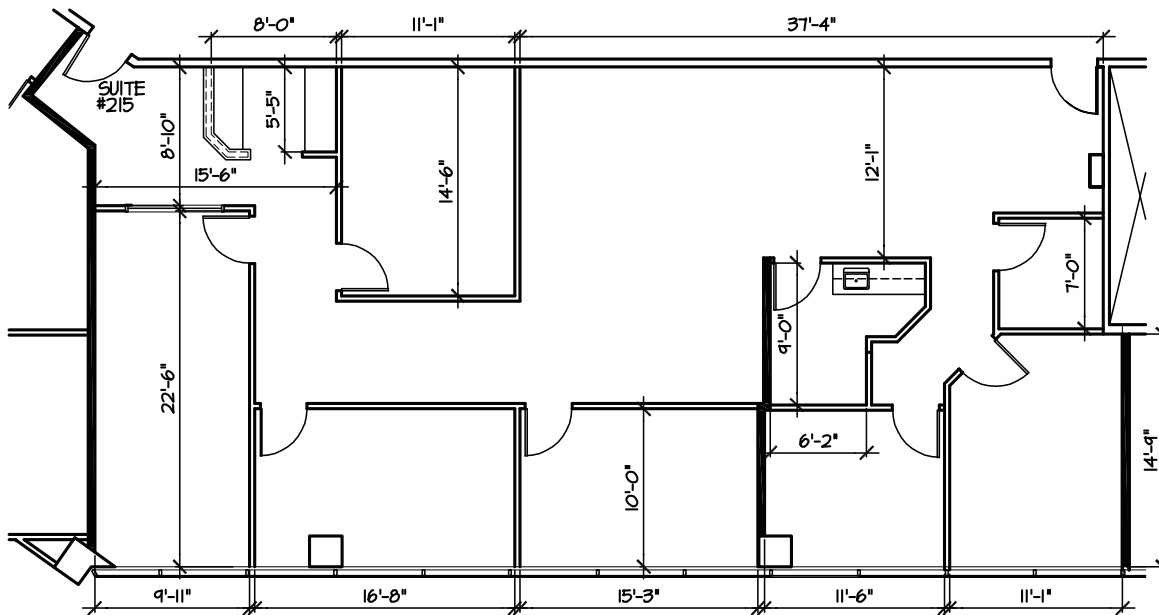

SUITE HIGHLIGHTS:

- Four (4) Large Window-Line Offices
- One (1) Interior Office
- One (1) Conference Room
- Enclosed Kitchen Area
- Reception Bay
- Bullpen
- Storage / IT

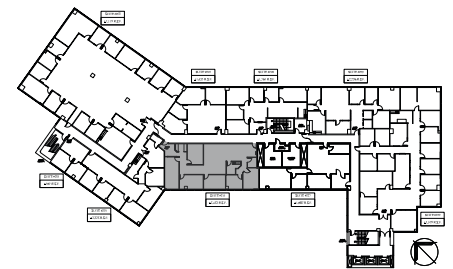

FLOOR PLAN

Third Floor



SUITE	RSF
302	6,777
306	1,463
307	958

*Suites 302, 306 & 307 can be combined for a contiguous 9,198 RSF

FLOOR PLAN

Suite 302 - 6,777 RSF

**Can be combined with Suite 306 for 8,240 RSF*

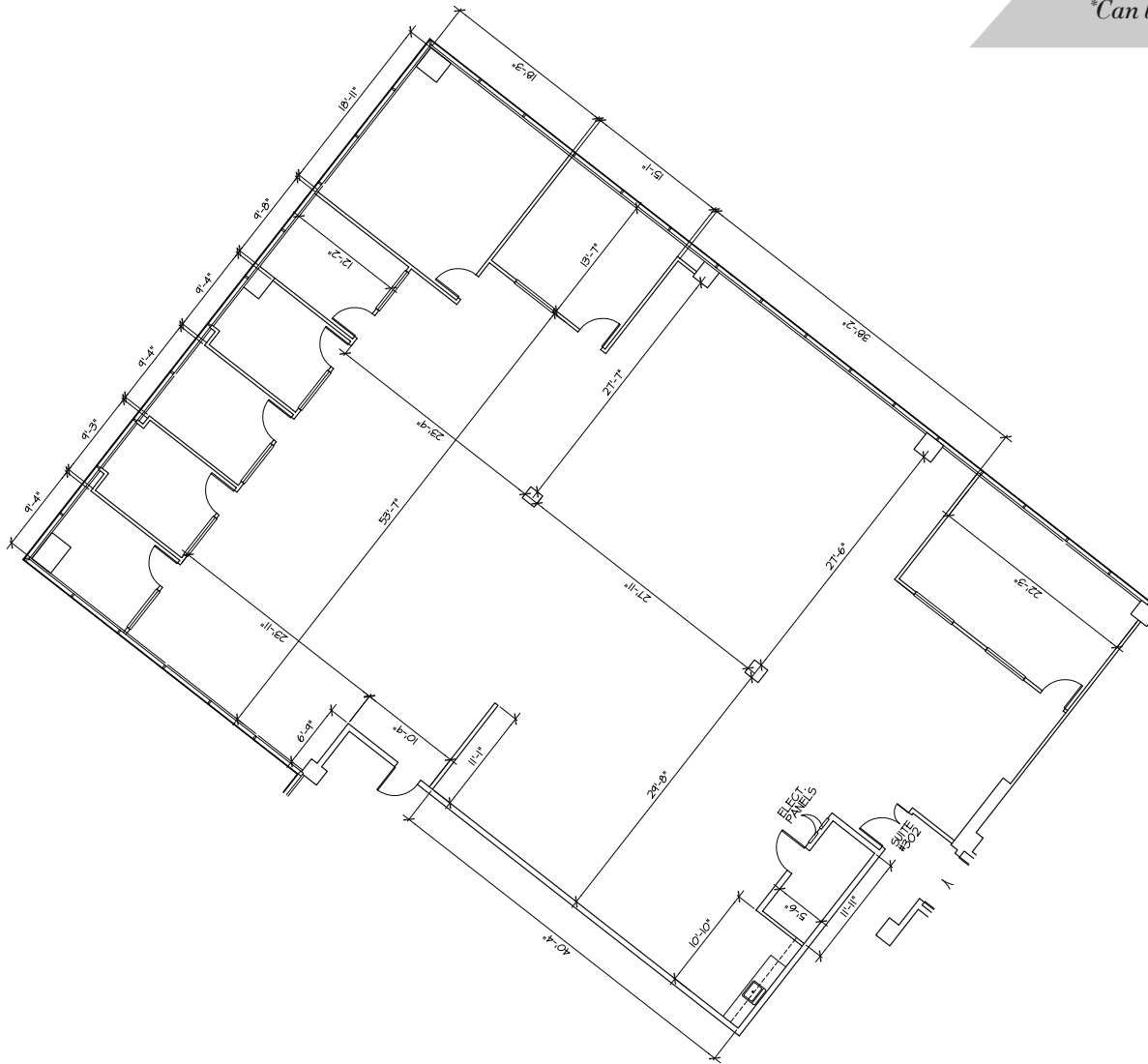

SUITE HIGHLIGHTS:

- Glass Conference Room Off Reception
- Six (6) Windowed Offices
- Large Corner Executive Office
- Ample Bullpen Space
- Open Kitchen Concept
- IT Room
- Creative Space w/ Above Standard Finishes

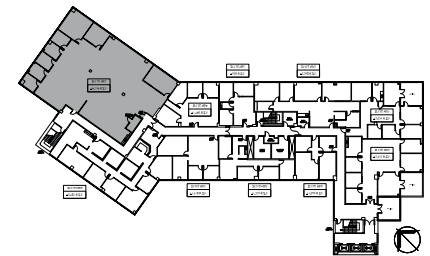

FLOOR PLAN

Suite 306 - 1,463 RSF

**Can be combined with Suite 302 for 8,240 RSF*

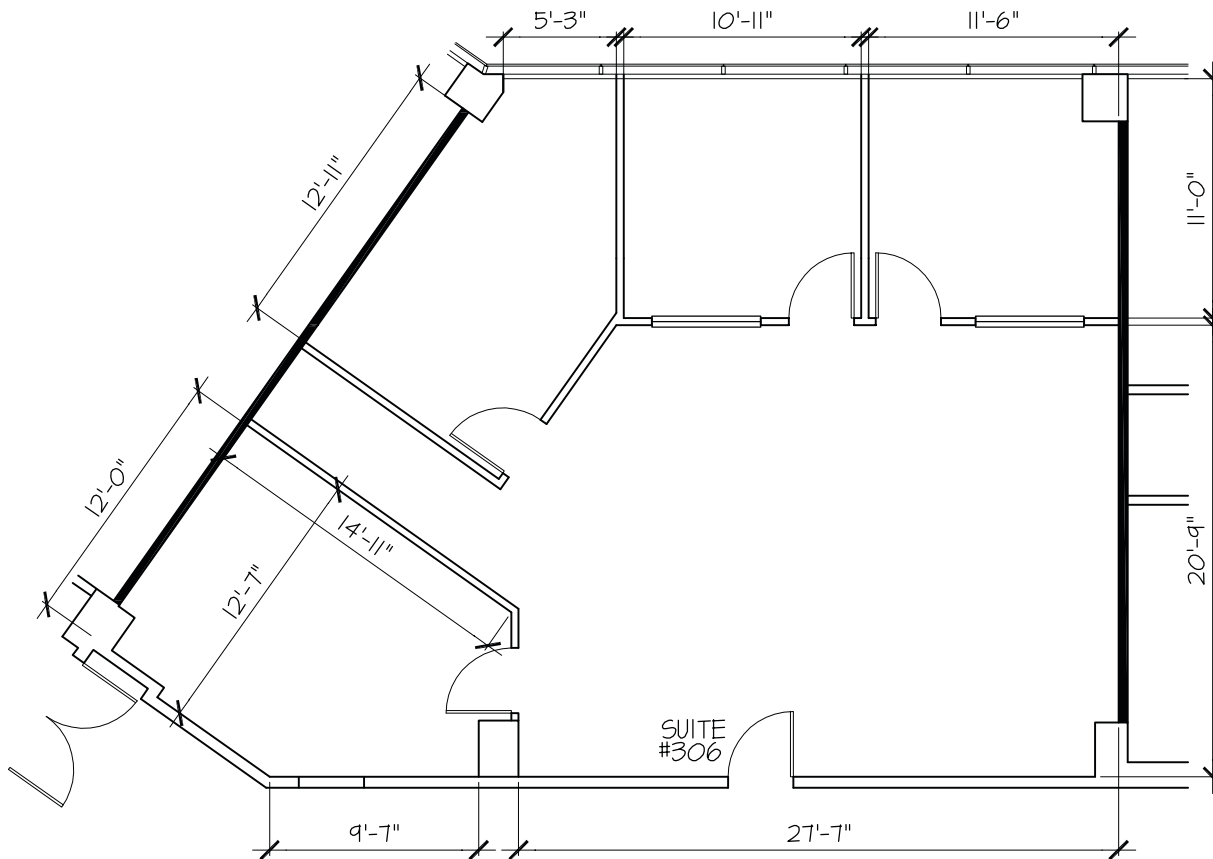

SUITE HIGHLIGHTS:

- Three (3) Windowed Offices
- Interior Room for Conference Area or Large Storage/Break Area
- Bullpen Space
- Small File/Printer Hallway

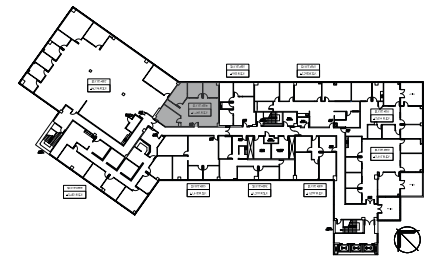

FLOOR PLAN

Suite 307 - 958 RSF

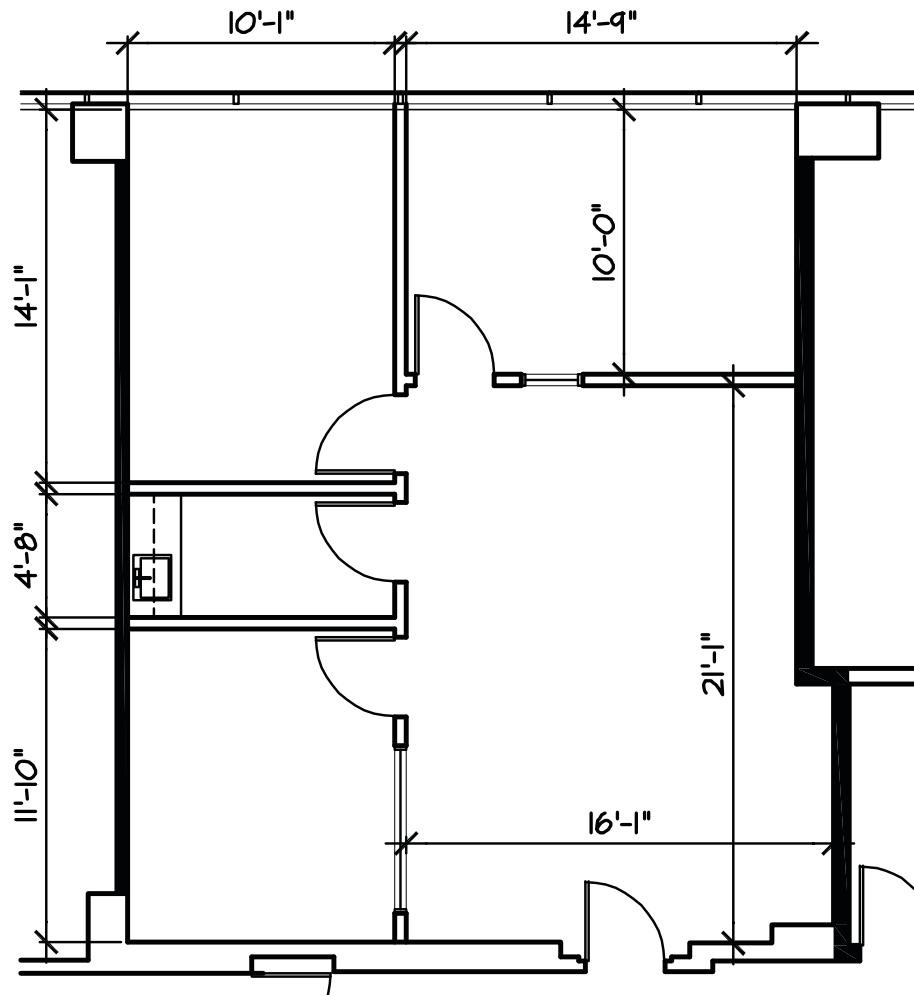

SUITE HIGHLIGHTS:

- Three (3) Private Offices
- Kitchenette with Sink and Plumbing
- Small Open Area for Workstations and/or Reception

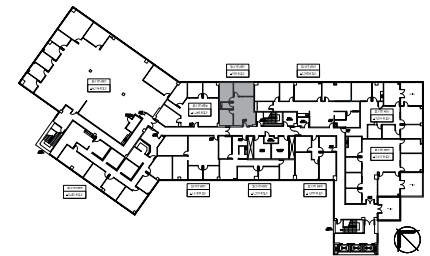



TARZANA OFFICE PLAZA

DALTON SABERHAGEN

Vice President
Lic. 01971713
+1 818 251 3613
dalton.saberhagen@cbre.com

BOB PEARSON

Senior Vice President
Lic. 01135353
+1 310 363 4675
bob.pearson@cbre.com

NICK MORAN

Associate
Lic. 02206836
+1 805 231 3449
nick.moran@cbre.com

© 2024 CBRE, Inc. All rights reserved. This information has been obtained from reliable sources but has not been verified for accuracy or completeness. CBRE, Inc. makes no guarantee, representation, or warranty and accepts no responsibility or liability for the accuracy, completeness, or reliability of the information contained herein. You should conduct a careful, independent investigation of the property and verify all information. Any reliance on this information is solely at your own risk. CBRE and the CBRE logo are service marks of CBRE, Inc. All other marks displayed on this document are the property of their respective owners, and the use of such marks does not imply any affiliation with or endorsement of CBRE. Photos herein are the property of their respective owners. Use of these images without the express written consent of the owner is prohibited.

CBRE

18757 BURBANK BOULEVARD | TARZANA, CA