

1st Floor

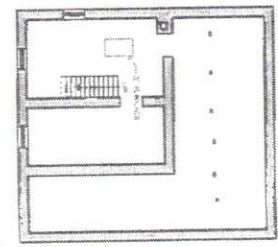
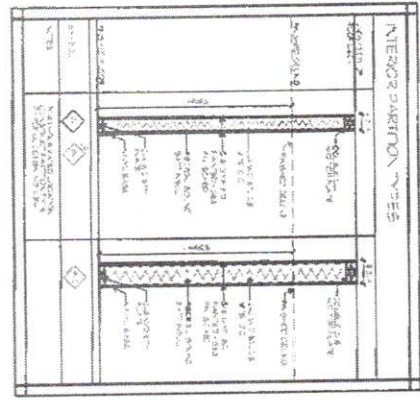
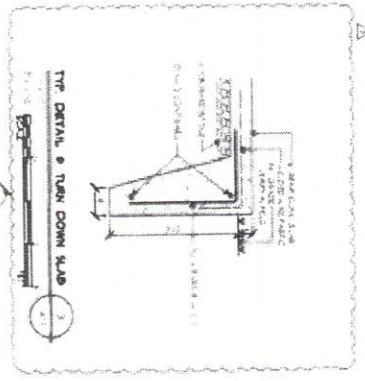
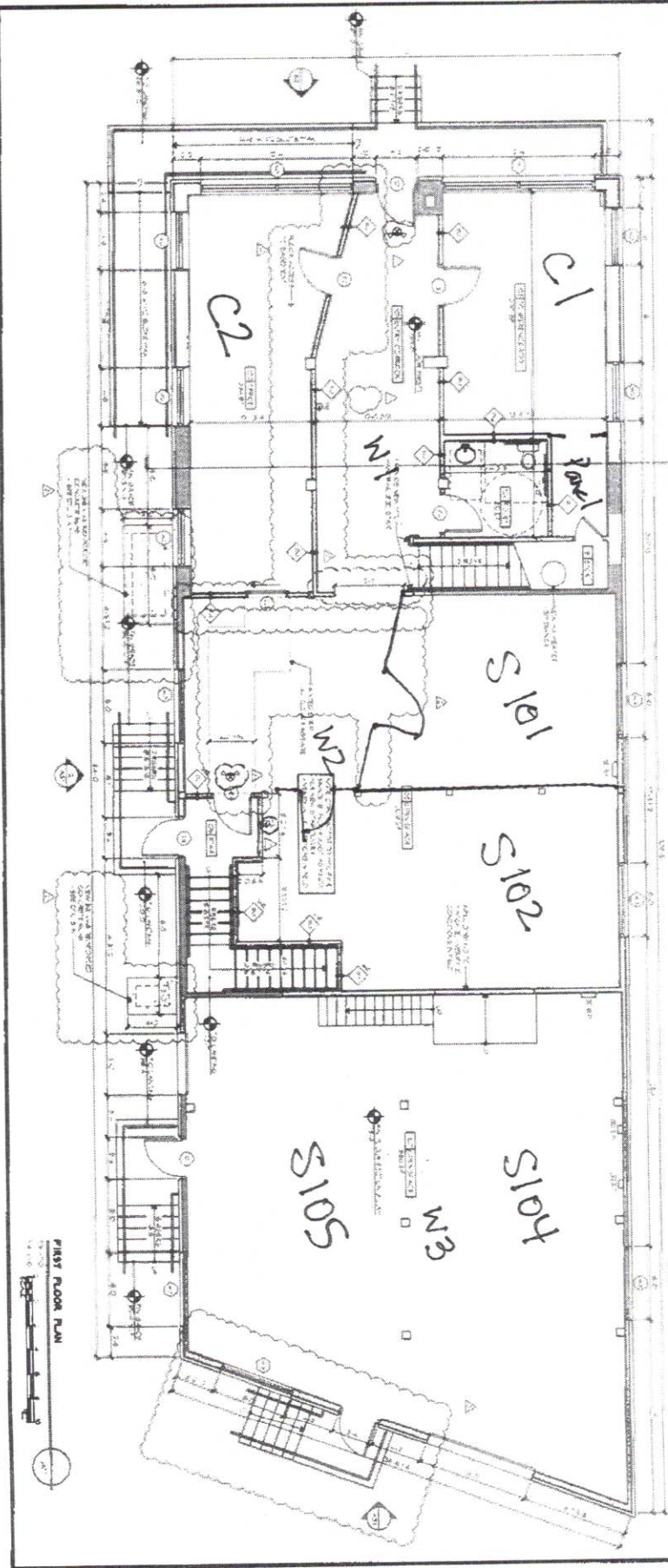

FIRST FLOOR PLAN

DASHBOARD PLAN

S101 - 284 SQ  
S102 - 466 SQ

Overall  
FIRST FLOOR  
A11  
OF SHEETS  
DATE: 02/20/12

**BFM** BUSHEY FEIGHT MORIN ARCHITECTS  
472 NORTH POTOMAC STREET, RAGERSTOWN, MD 20760  
BFMARCHITECTS.COM | 301-783-6500 | FAX 301-783-5812  
© 2012, BUSHEY FEIGHT MORIN ARCHITECTS, INC.

BFM# 22003 NASH HOMES  
OFFICE BUILDING RENOVATION



THIS DOCUMENT IS THE PROPERTY OF BUSHEY FEIGHT MORIN ARCHITECTS, INC. IT IS TO BE USED ONLY FOR THE PROJECT AND SITE SPECIFICALLY IDENTIFIED HEREIN. IT IS NOT TO BE REPRODUCED, COPIED, OR TRANSMITTED IN ANY FORM OR BY ANY MEANS, ELECTRONIC OR MECHANICAL, INCLUDING PHOTOCOPYING, RECORDING, OR BY ANY INFORMATION STORAGE AND RETRIEVAL SYSTEM, WITHOUT THE WRITTEN PERMISSION OF BUSHEY FEIGHT MORIN ARCHITECTS, INC.

THIS DOCUMENT IS THE PROPERTY OF BUSHEY FEIGHT MORIN ARCHITECTS, INC. IT IS TO BE USED ONLY FOR THE PROJECT AND SITE SPECIFICALLY IDENTIFIED HEREIN. IT IS NOT TO BE REPRODUCED, COPIED, OR TRANSMITTED IN ANY FORM OR BY ANY MEANS, ELECTRONIC OR MECHANICAL, INCLUDING PHOTOCOPYING, RECORDING, OR BY ANY INFORMATION STORAGE AND RETRIEVAL SYSTEM, WITHOUT THE WRITTEN PERMISSION OF BUSHEY FEIGHT MORIN ARCHITECTS, INC.

THIS DOCUMENT IS THE PROPERTY OF BUSHEY FEIGHT MORIN ARCHITECTS, INC. IT IS TO BE USED ONLY FOR THE PROJECT AND SITE SPECIFICALLY IDENTIFIED HEREIN. IT IS NOT TO BE REPRODUCED, COPIED, OR TRANSMITTED IN ANY FORM OR BY ANY MEANS, ELECTRONIC OR MECHANICAL, INCLUDING PHOTOCOPYING, RECORDING, OR BY ANY INFORMATION STORAGE AND RETRIEVAL SYSTEM, WITHOUT THE WRITTEN PERMISSION OF BUSHEY FEIGHT MORIN ARCHITECTS, INC.

2nd Floor

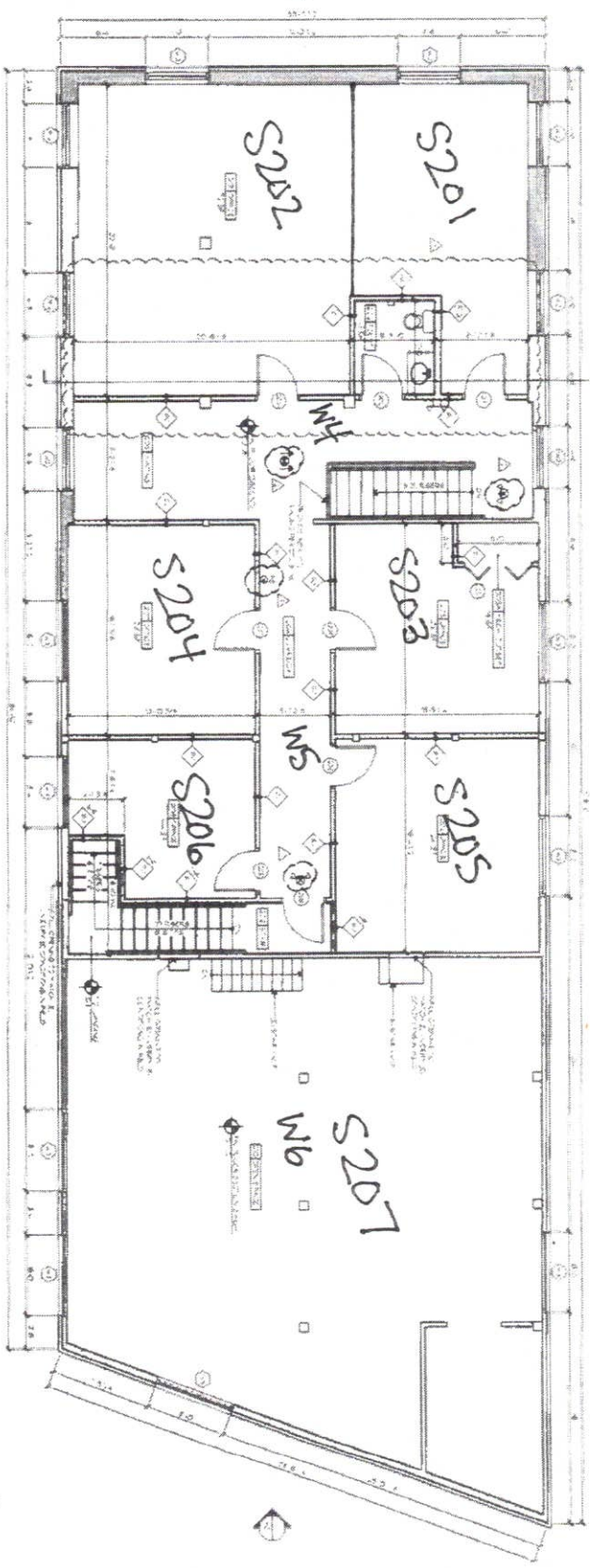

- S 201 - 310 SQ
- S 202 - 429 SQ
- S 203 - 236 SQ
- S 204 - 211 SQ
- S 205 - 233 SQ
- S 206 - 171 SQ



SECOND FLOOR PLAN  
DATE: 03/24/22

OVERALL  
SECOND FLOOR  
A1.2  
DATE: 03/24/22

**BFM** BUSHEY FEIGHT MORIN ARCHITECTS  
478 NORTH POTOMAC STREET, HAGERSTOWN, MD 21740  
BFMARCHITECTS.COM • 301-733-6800 • FAX 301-733-6812  
© 2022, BUSHEY FEIGHT MORIN ARCHITECTS, INC.

BFM# 22003 NASH HOMES OFFICE BUILDING RENOVATION



1. ALL WORK SHALL BE IN ACCORDANCE WITH THE LATEST EDITIONS OF THE BUILDING CODES AND REGULATIONS OF THE STATE OF MARYLAND AND THE DISTRICT OF COLUMBIA.

2. THE ARCHITECT SHALL BE RESPONSIBLE FOR OBTAINING ALL NECESSARY PERMITS AND APPROVALS FROM THE APPROPRIATE AGENCIES.

3. THE CONTRACTOR SHALL BE RESPONSIBLE FOR OBTAINING ALL NECESSARY PERMITS AND APPROVALS FROM THE APPROPRIATE AGENCIES.

4. THE CONTRACTOR SHALL BE RESPONSIBLE FOR OBTAINING ALL NECESSARY PERMITS AND APPROVALS FROM THE APPROPRIATE AGENCIES.

5. THE CONTRACTOR SHALL BE RESPONSIBLE FOR OBTAINING ALL NECESSARY PERMITS AND APPROVALS FROM THE APPROPRIATE AGENCIES.

6. THE CONTRACTOR SHALL BE RESPONSIBLE FOR OBTAINING ALL NECESSARY PERMITS AND APPROVALS FROM THE APPROPRIATE AGENCIES.

7. THE CONTRACTOR SHALL BE RESPONSIBLE FOR OBTAINING ALL NECESSARY PERMITS AND APPROVALS FROM THE APPROPRIATE AGENCIES.

8. THE CONTRACTOR SHALL BE RESPONSIBLE FOR OBTAINING ALL NECESSARY PERMITS AND APPROVALS FROM THE APPROPRIATE AGENCIES.

9. THE CONTRACTOR SHALL BE RESPONSIBLE FOR OBTAINING ALL NECESSARY PERMITS AND APPROVALS FROM THE APPROPRIATE AGENCIES.

10. THE CONTRACTOR SHALL BE RESPONSIBLE FOR OBTAINING ALL NECESSARY PERMITS AND APPROVALS FROM THE APPROPRIATE AGENCIES.

11. THE CONTRACTOR SHALL BE RESPONSIBLE FOR OBTAINING ALL NECESSARY PERMITS AND APPROVALS FROM THE APPROPRIATE AGENCIES.

12. THE CONTRACTOR SHALL BE RESPONSIBLE FOR OBTAINING ALL NECESSARY PERMITS AND APPROVALS FROM THE APPROPRIATE AGENCIES.

13. THE CONTRACTOR SHALL BE RESPONSIBLE FOR OBTAINING ALL NECESSARY PERMITS AND APPROVALS FROM THE APPROPRIATE AGENCIES.

14. THE CONTRACTOR SHALL BE RESPONSIBLE FOR OBTAINING ALL NECESSARY PERMITS AND APPROVALS FROM THE APPROPRIATE AGENCIES.

15. THE CONTRACTOR SHALL BE RESPONSIBLE FOR OBTAINING ALL NECESSARY PERMITS AND APPROVALS FROM THE APPROPRIATE AGENCIES.