



**COLDWELL BANKER
COMMERCIAL**
DEVONSHIRE
REALTY

FLEX BUILDING FOR LEASE

\$9.50 / SF / GROSS

FOR LEASE



307 S Locust St.

Champaign, IL 61820

3,600 SF

RETAIL

BUILDING SIZE

3,600 SF

AVAILABLE SPACE

3,600 SF

TAX PIN

42-20-12-494-006

PARKING SPACES

3+ Street Parking

TRAFFIC COUNTS

Locust St– 500 AADT

ZONING

CB1- Central Business
Urban Fringe

PROPERTY DESCRIPTION

307 S Locust Street offers approximately 3,600 square feet of versatile space, ideal for a variety of uses. The property features a bright and welcoming front showroom measuring approximately 41' x 17'-7", with large windows and heating and cooling for year-round comfort. Behind the showroom is a spacious, heated production area suitable for manufacturing, assembly, or other operational needs. Additional amenities include a kitchenette, a single restroom, and an approximately 650-square-foot warehouse with a 9'-9" wide x 12'-4" high overhead door for convenient loading and unloading. The building also includes a significant amount of second-floor storage space, which is not included in the rentable square footage or tenant charges, providing added value for tenants.

AREA DESCRIPTION

The property boasts a central location at the corner of Locust Street and Willow Street, just one block west of 1st Street and two blocks north of Springfield Avenue. Its location offers easy access to Champaign, Urbana, and the University of Illinois, making it an ideal location for businesses serving the local community and campus. The surrounding area is a diverse mix of retail, warehouse, and residential properties, creating an environment with a variety of nearby amenities and opportunities.



JOSH MARKIEWICZ

217-403-3424

joshm@cbcdr.com

cbcdr.com



**COLDWELL BANKER COMMERCIAL
DEVONSHIRE REALTY**

201 W Springfield Ave. 11th Floor
Champaign, IL 61820
217-352-7712

©2023 Coldwell Banker. All Rights Reserved. Coldwell Banker Commercial® and the Coldwell Banker Commercial logos are trademarks of Coldwell Banker Real Estate LLC. The Coldwell Banker® System is comprised of company owned offices which are owned by a subsidiary of Anywhere Advisors LLC and franchised offices which are independently owned and operated. The Coldwell Banker System fully supports the principles of the Equal Opportunity Act.



FLOOR PLAN

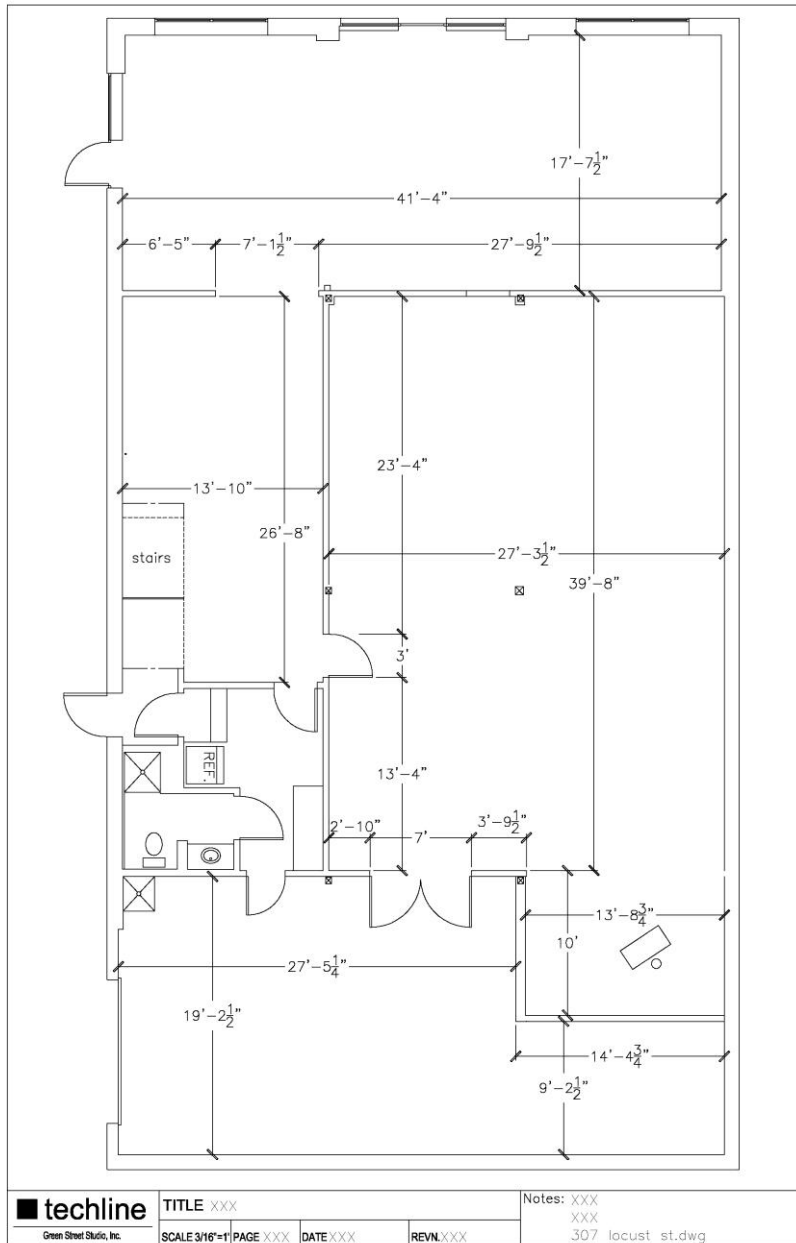

JOSH MARKIEWICZ
217-403-3424
joshm@cbcdr.com
cbcdr.com

