



**PRIME RETAIL FOR LEASE**

# CAROLINE RALSTON CREEK

Kipling St. and 58th Ave.  
Arvada, CO 80002

**NAI** Shames Makovsky

**RETAIL LEASING:**

**Robert A. Hudgins**  
303 565 3033

**Cory Dulberg**  
303 565 3039  
[cdulberg@shamesmakovsky.com](mailto:cdulberg@shamesmakovsky.com)

[rhudgins@shamesmakovsky.com](mailto:rhudgins@shamesmakovsky.com)

DEVELOPMENT  
BY





# CAROLINE RALSTON CREEK

New to market retail in vibrant Arvada submarket

- Retail Suites ranging from 1,006 to 6,154 SF
- Dedicated retail surface parking
- Strong visibility on 58th Avenue
- Street level retail in new residential multifamily community

## Project Overview

<b>Retail Leasable Area</b>	<b>10,000 SF</b>
<b>Land Area</b>	<b>8.4 AC</b>
<b>Construction Start</b>	<b>Under Construction</b>
<b>Residential Units</b>	<b>328</b>
<b>Residential First Occupancy</b>	<b>June 2024</b>









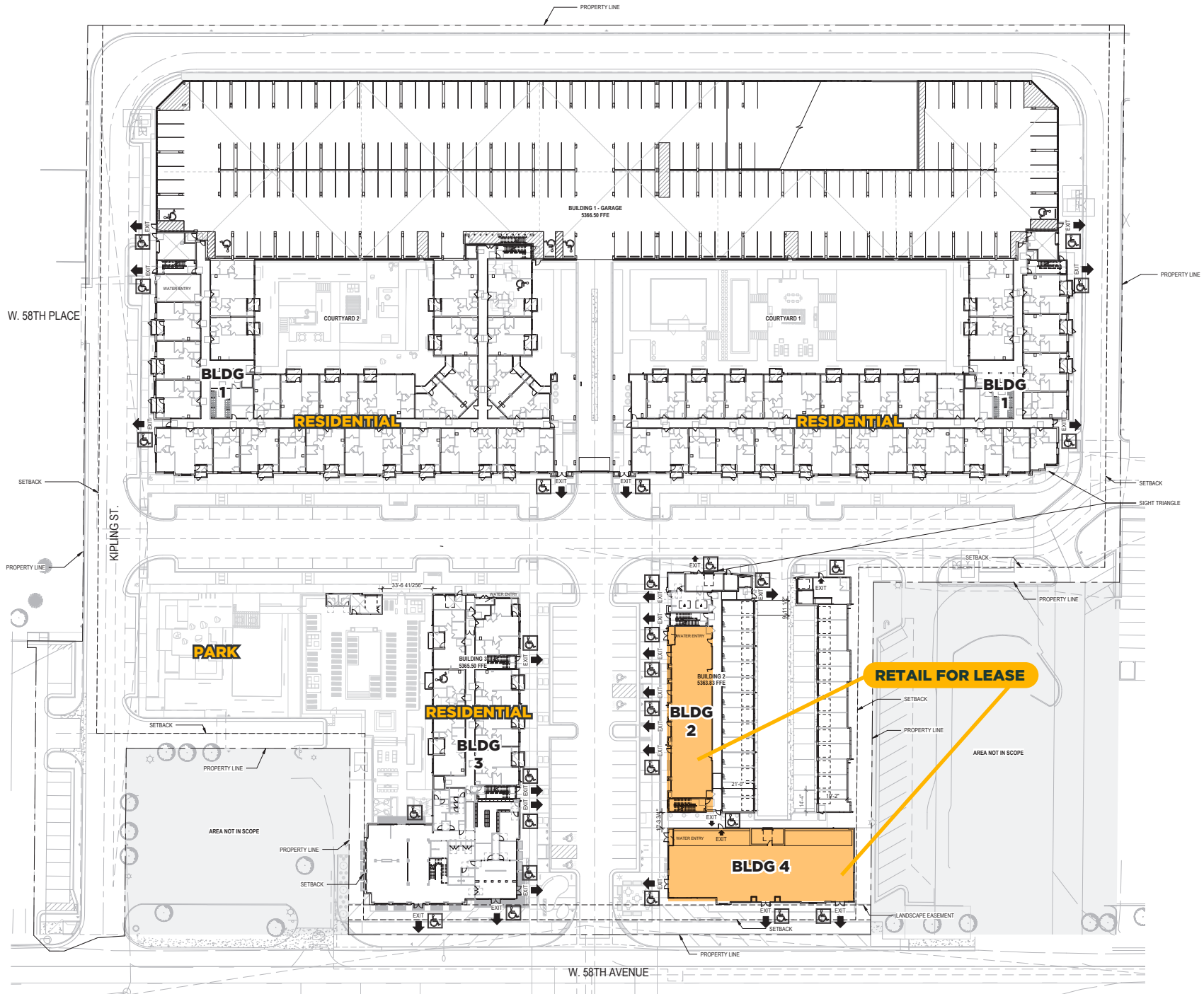

W. 58TH PLACE

SETBACK

PROPERTY LINE

KIPLING ST.

PARK

BLDG 1

RESIDENTIAL

COURTYARD 2

BUILDING 1 - GARAGE  
5386.50 FFE

BLDG 1

RESIDENTIAL

COURTYARD 1

BLDG 1

PROPERTY LINE

SETBACK

SIGHT TRIANGLE

RESIDENTIAL

BLDG 3

BUILDING 3  
5385.50 FFE

AREA NOT IN SCOPE

PROPERTY LINE

SETBACK

BLDG 2

BUILDING 2  
5385.50 FFE

RETAIL FOR LEASE

SETBACK

PROPERTY LINE

AREA NOT IN SCOPE

BLDG 4

LANDSCAPE EASEMENT

W. 58TH AVENUE

PROPERTY LINE

SETBACK



# RETAIL FOR LEASE CAROLINE RALSTON CREEK



**BUILDING 2**

**BUILDING 4**

**58TH AVENUE (21,939 VPD)**





# BUILDING 2 RETAIL

## TWO TENANT OPTION

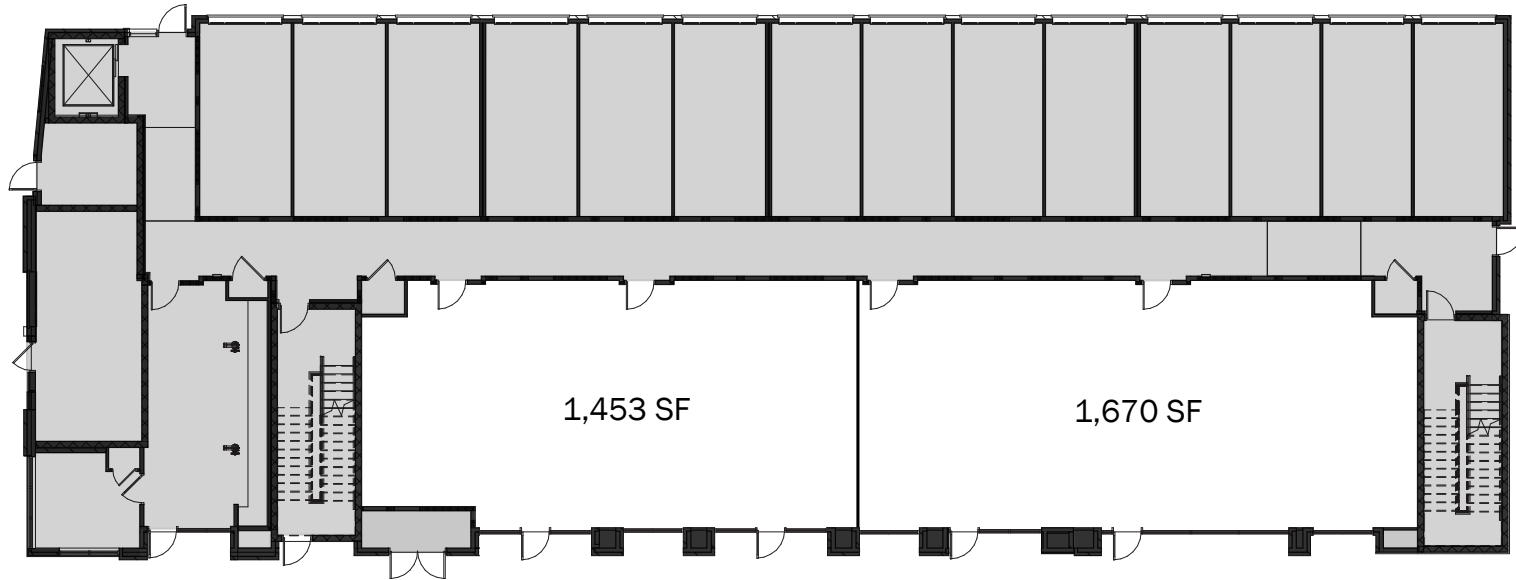

## THREE TENANT OPTION

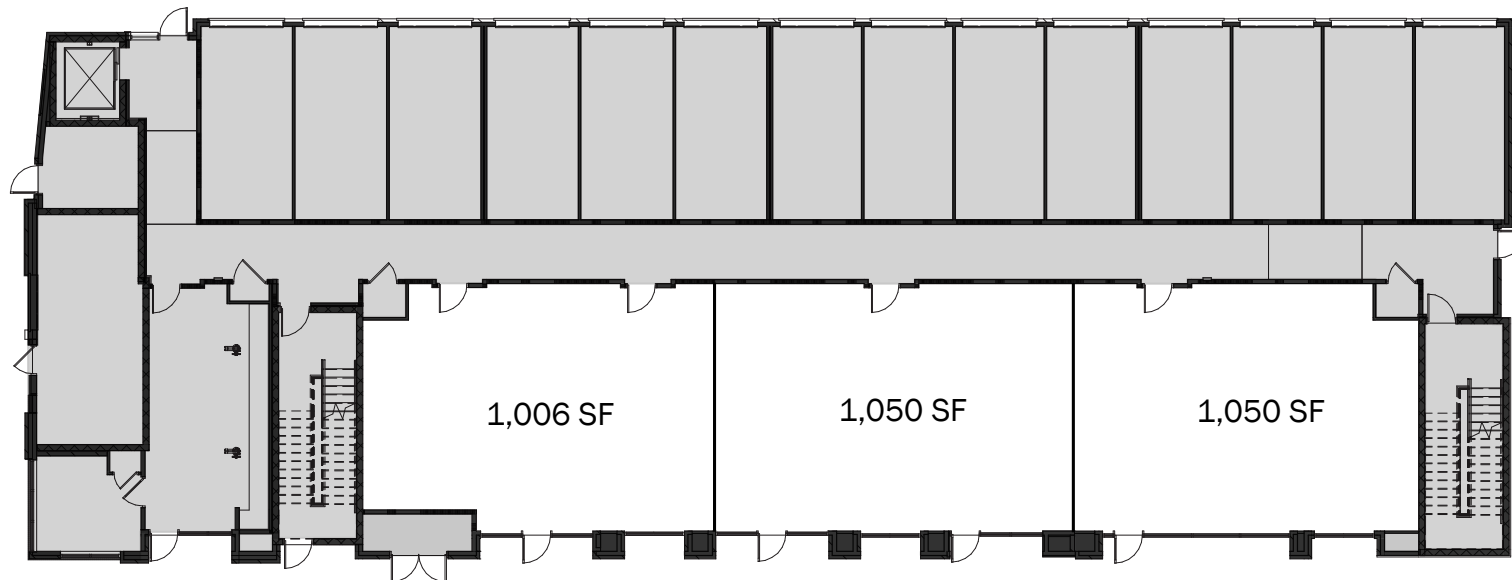



# BUILDING 4 RETAIL

## TWO TENANT OPTION



## SINGLE TENANT OPTION

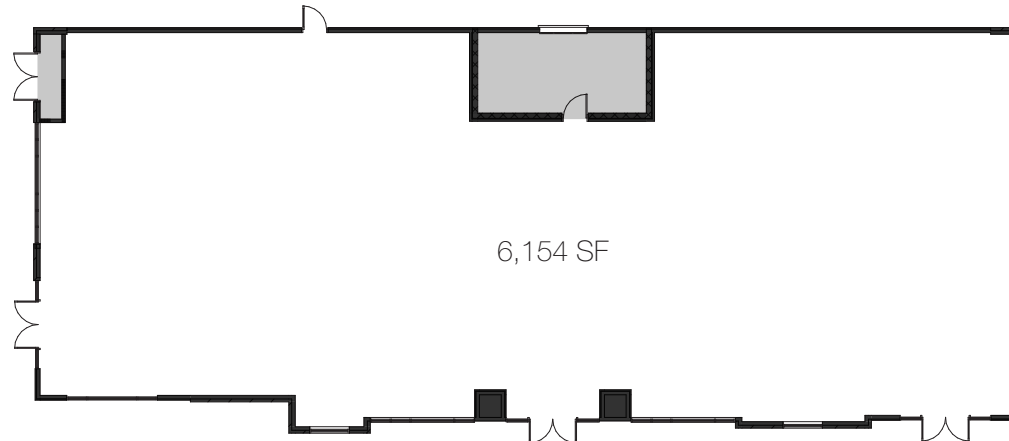



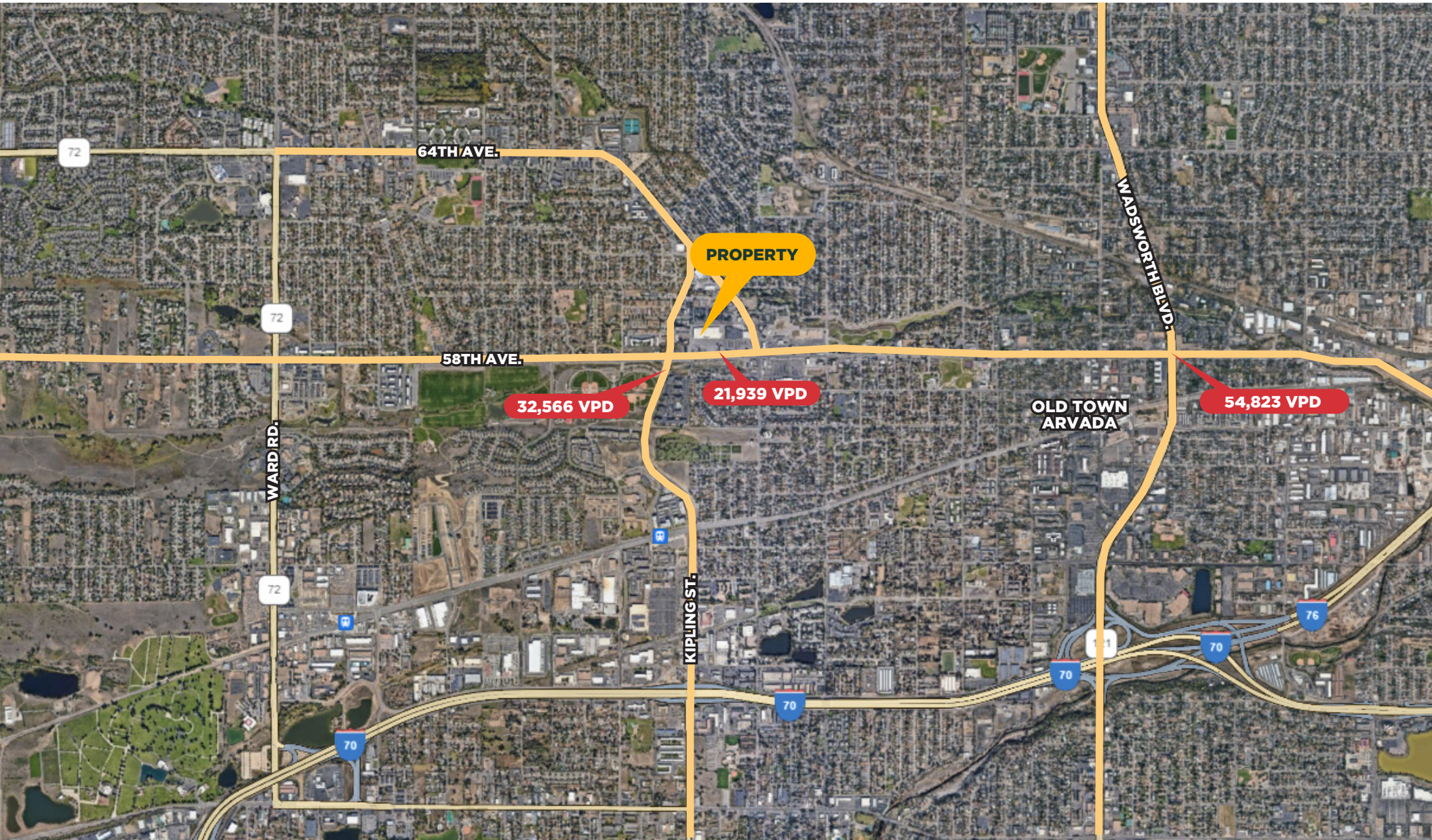



# NEARBY DEVELOPMENT



NEARBY DEVELOPMENT



**RALSTON CREEK TOWNHOMES**

- 47 for sale townhomes
- Completed by 2025
- Estimated cost \$15,000,000



**RALSTON COMMONS**

- 185 apartments
- 27 for sale townhomes
- 5,500 SF of retail
- Completed by 2027
- Estimated cost \$73,500,000



**RALSTON GARDENS**

- 102 affordable units
- Completed by 2024
- Estimated cost \$38,000,000

# ARVADA, CO

Nearby Olde Town Arvada (1 Mile to the East) is the heart and soul of the City.

Downtown Arvada is where historic roots intermingle with new and fresh ideas providing a one of a kind authentic experience in a relaxed atmosphere. With a diverse array of shops, boutiques, galleries, events, restaurants, breweries and a winery, Olde Town has all of the amenities of a thriving urban hub set within a turn-of-the-century Main Street Americana ambiance.



## AREA DEMOGRAPHICS

	1 MI	3 MI	5 MI
<b>DAYTIME POPULATION</b>	<b>15,342</b>	<b>102,873</b>	<b>294,297</b>
<b>POPULATION</b>	<b>18,460</b>	<b>106,788</b>	<b>289,496</b>
<b>MEDIAN HOUSEHOLD INCOME</b>	<b>\$69,955</b>	<b>\$92,158</b>	<b>\$96,138</b>
<b>TRAFFIC</b>	<b>Kipling Street at 58th: 24,741 VPD</b> <b>58th Ave. at Kipling Street: 20,996 VPD</b>		





# CAROLINE RALSTON CREEK

Kipling St. and 58th Ave.  
Arvada, CO 80002

**NAI** Shames Makovsky

**Cory Dulberg**  
303 565 3039

[cdulberg@shamesmakovsky.com](mailto:cdulberg@shamesmakovsky.com)

**Robert A. Hudgins**  
303 565 3033

[rhudgins@shamesmakovsky.com](mailto:rhudgins@shamesmakovsky.com)

DEVELOPMENT  
BY

