

# 1111 TOUHY AVENUE

**LA** LEE & ASSOCIATES  
COMMERCIAL REAL ESTATE SERVICES



Property Management  
Service Provided by:

**LA** LEE & ASSOCIATES  
ASSET MANAGEMENT

1111 TOUHY AVENUE | DES PLAINES | ILLINOIS

# 1111 TOUHY HIGHLIGHTS

- FIVE STORY, 148,000 SF MULTI-TENANT OFFICE BUILDING OFFERING VIEWS OF CHICAGO O'HARE INTERNATIONAL AIRPORT & LAKE OPEKA
- GORGEOUS NATURAL SUNLIT, TWO-STORY ATRIUM WITH TERRAZZO FLOORING
- GROUND FLOOR DELI AND CAFE SEATING
- ON CAMPUS FITNESS CENTER AVAILABLE
- FULLY CUSTOMIZABLE OFFICE SPACES
- MINUTES FROM I-90 & I-294
- LOCATED IN CLOSE PROXIMITY TO NUMEROUS DINING & HOTEL OPTIONS, FASHION OUTLETS OF CHICAGO, RIVERS CASINO, MULTIPLE THEATERS, O'HARE INTERNATIONAL AIRPORT AND MORE!
- REPRESENTING 450,000 OF SQUARE FEET OF OFFICE SPACE, O'HARE OFFICES PROFESSIONAL, ON-SITE MANAGEMENT TEAM ANTICIPATES AND ADAPTS TO THE BUSINESS NEEDS OF ITS TENANTS, PROVIDING THOSE WITH AN O'HARE OFFICES ADDRESS THE HIGHEST LEVEL OF SERVICE AND VALUE.



# AVAILABLE SUITES

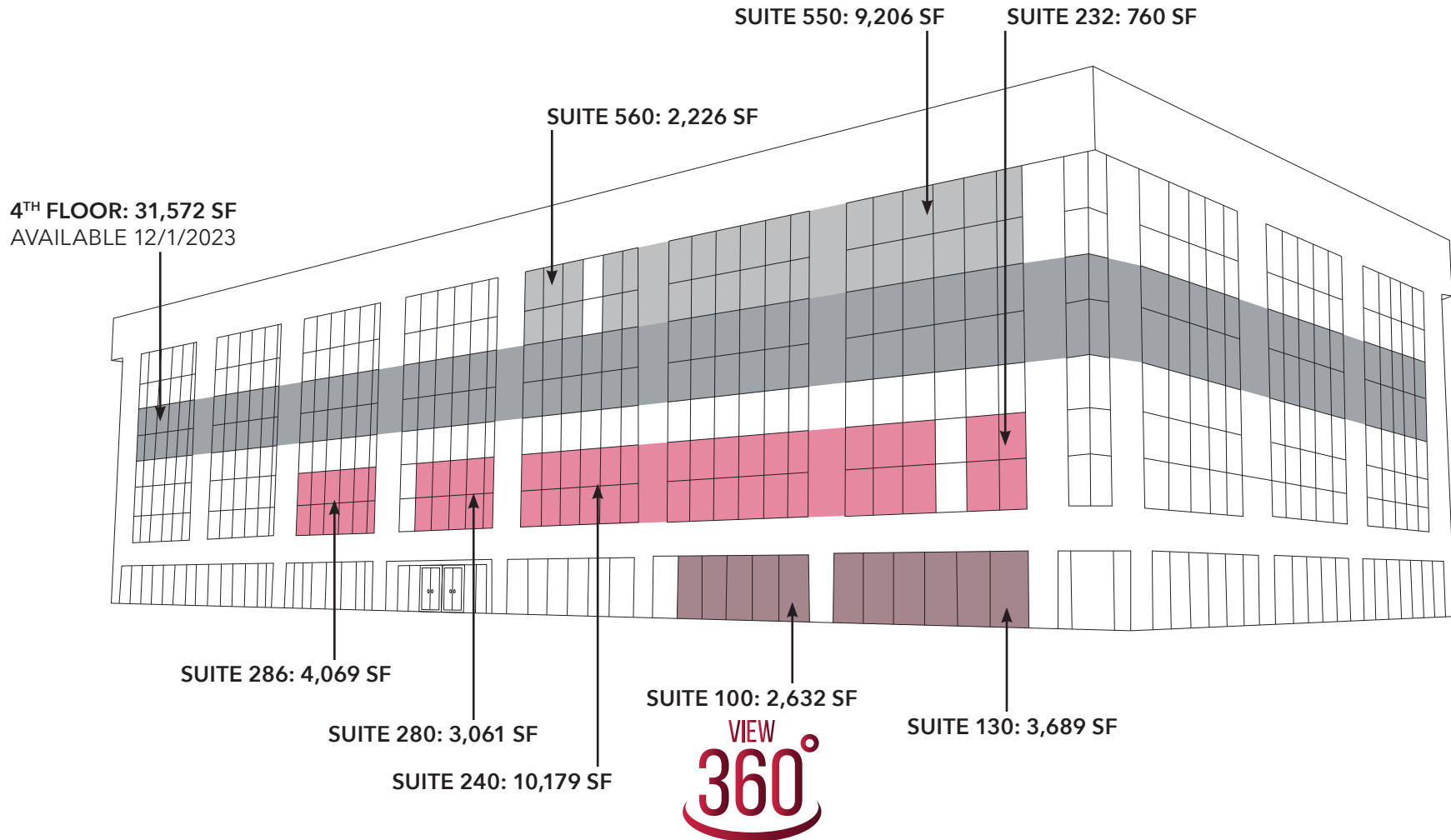

LEASE RATE FOR ALL AVAILABLE SUITES: \$23.50 PSF MG

# FIRST FLOOR

**SUITE 100** VIEW **360°**  
2,632 SF AVAILABLE

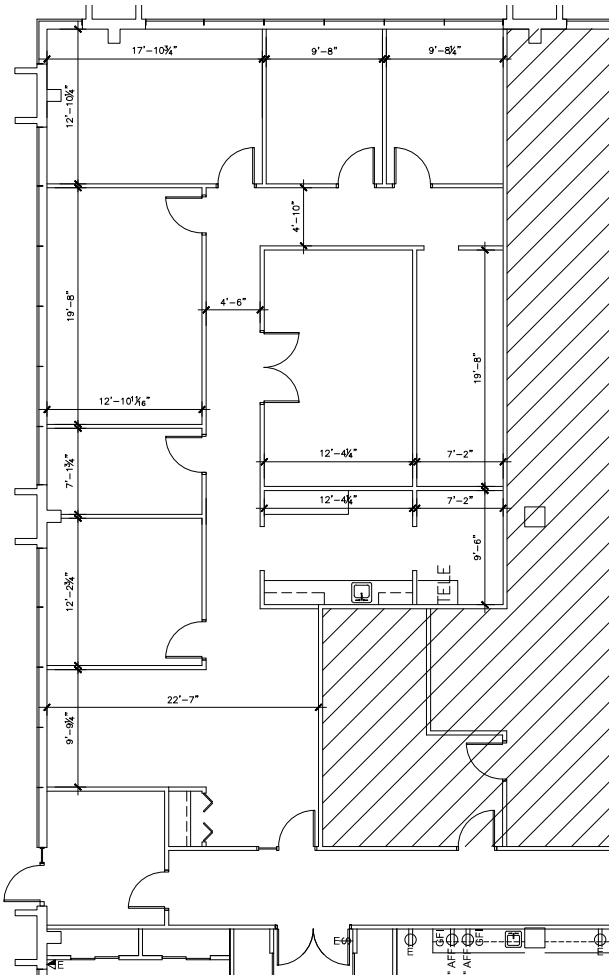

**SUITE 130**  
3,689 SF AVAILABLE

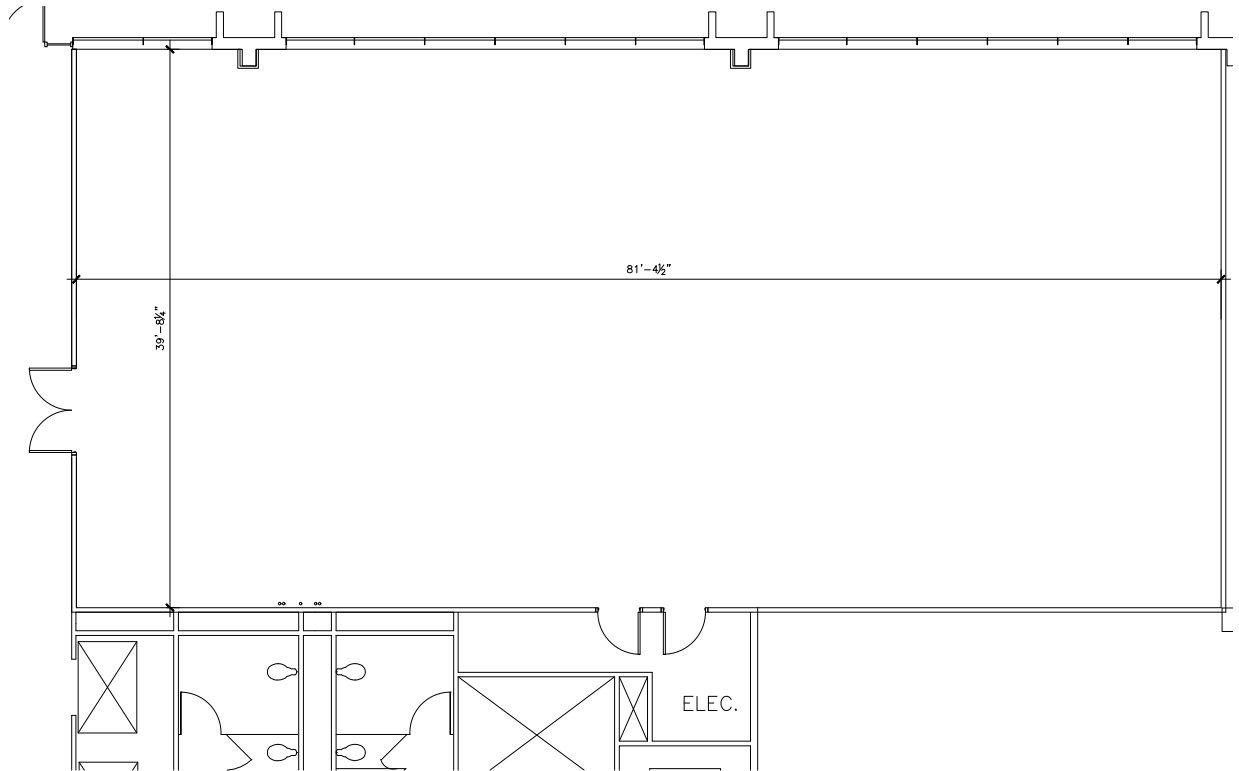

# SECOND FLOOR

**SUITE 232**  
760 SF AVAILABLE

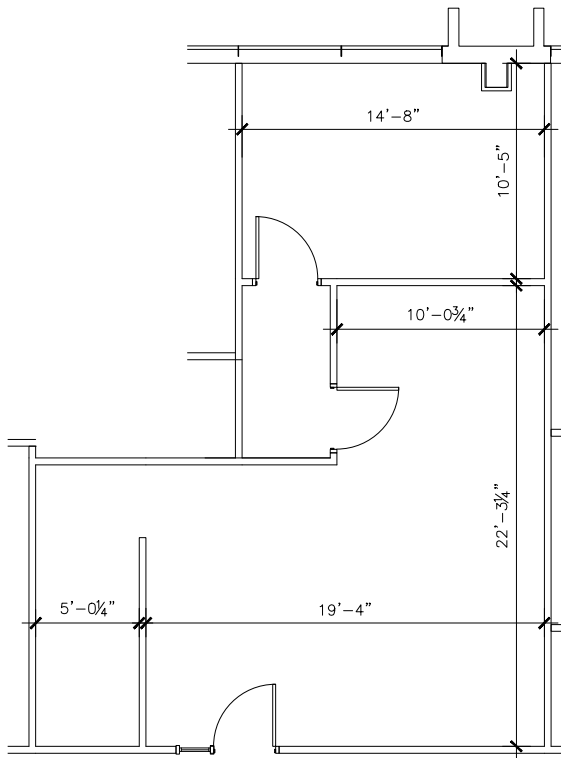

**SUITE 240**  
10,179 SF AVAILABLE

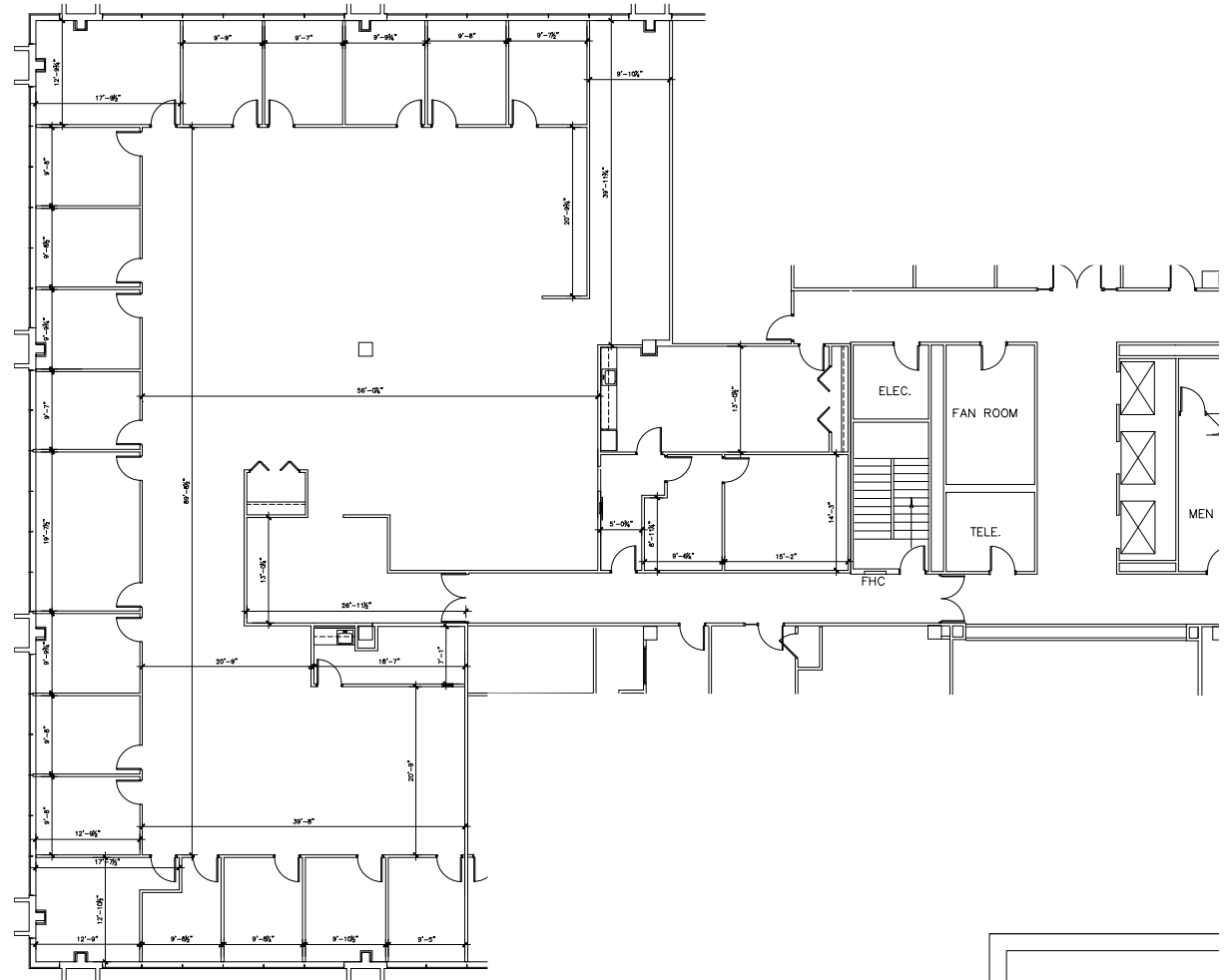

# SECOND FLOOR

## SUITE 286

4,069 SF AVAILABLE

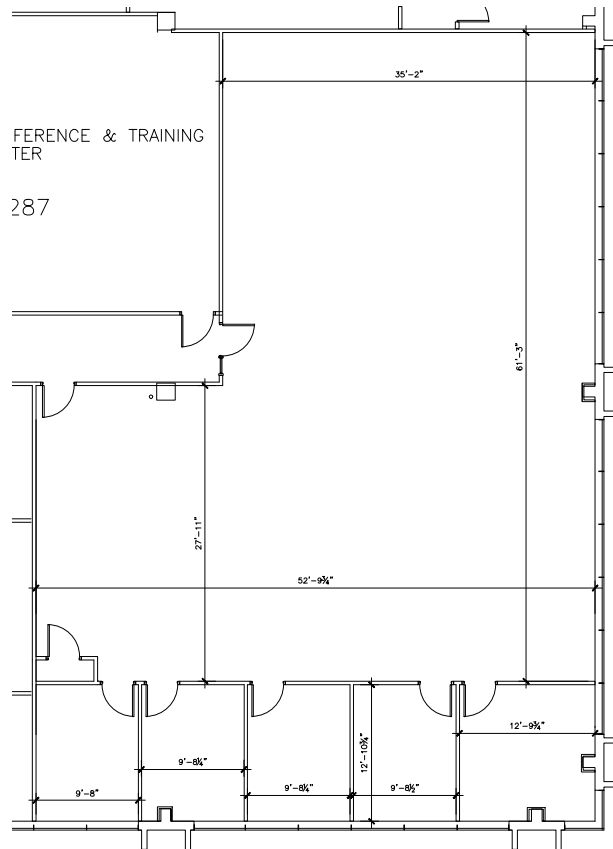

## SUITE 280

3,061 SF AVAILABLE

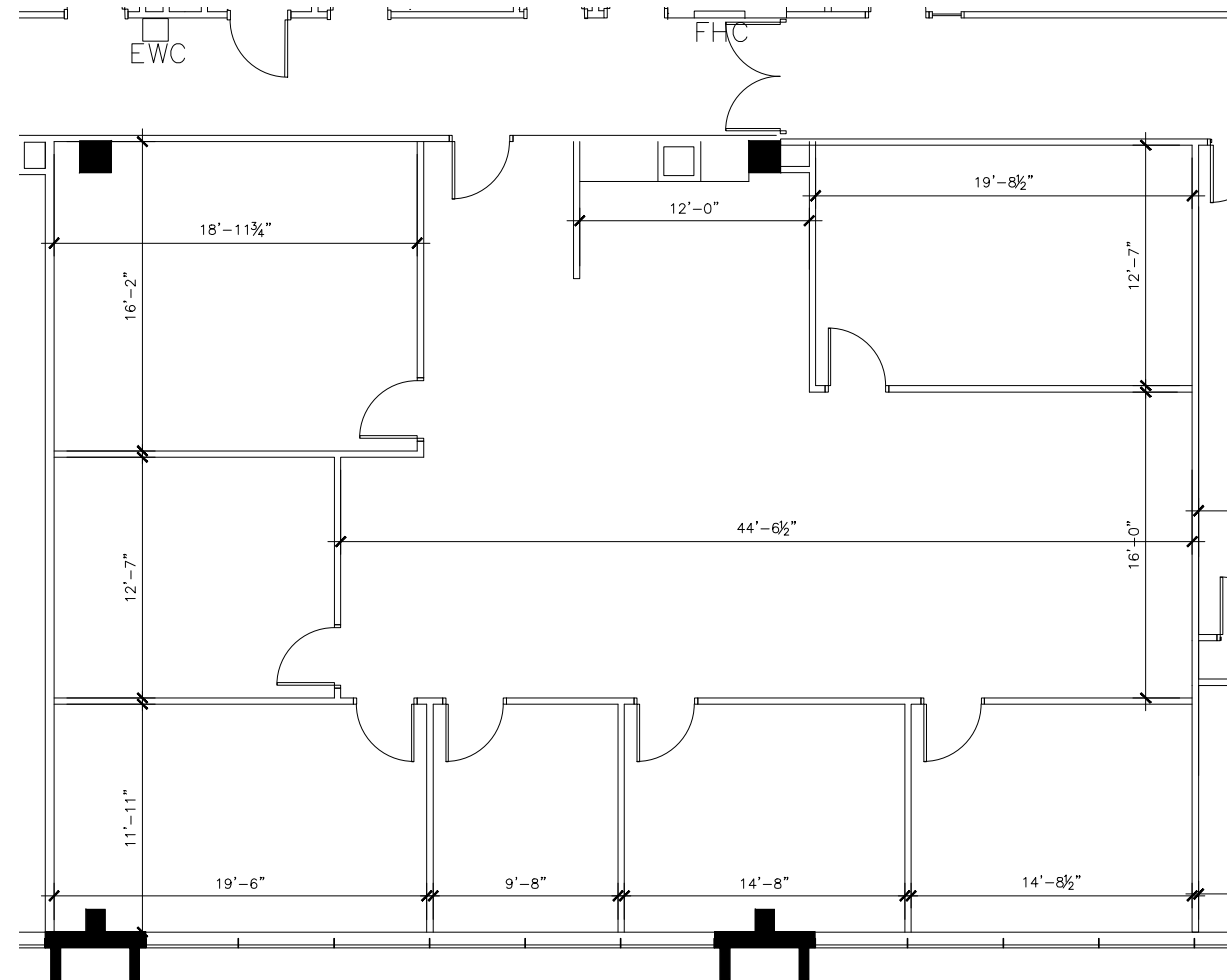

# FOURTH FLOOR

## ENTIRE FLOOR

31,572 SF AVAILABLE 12/1/2023

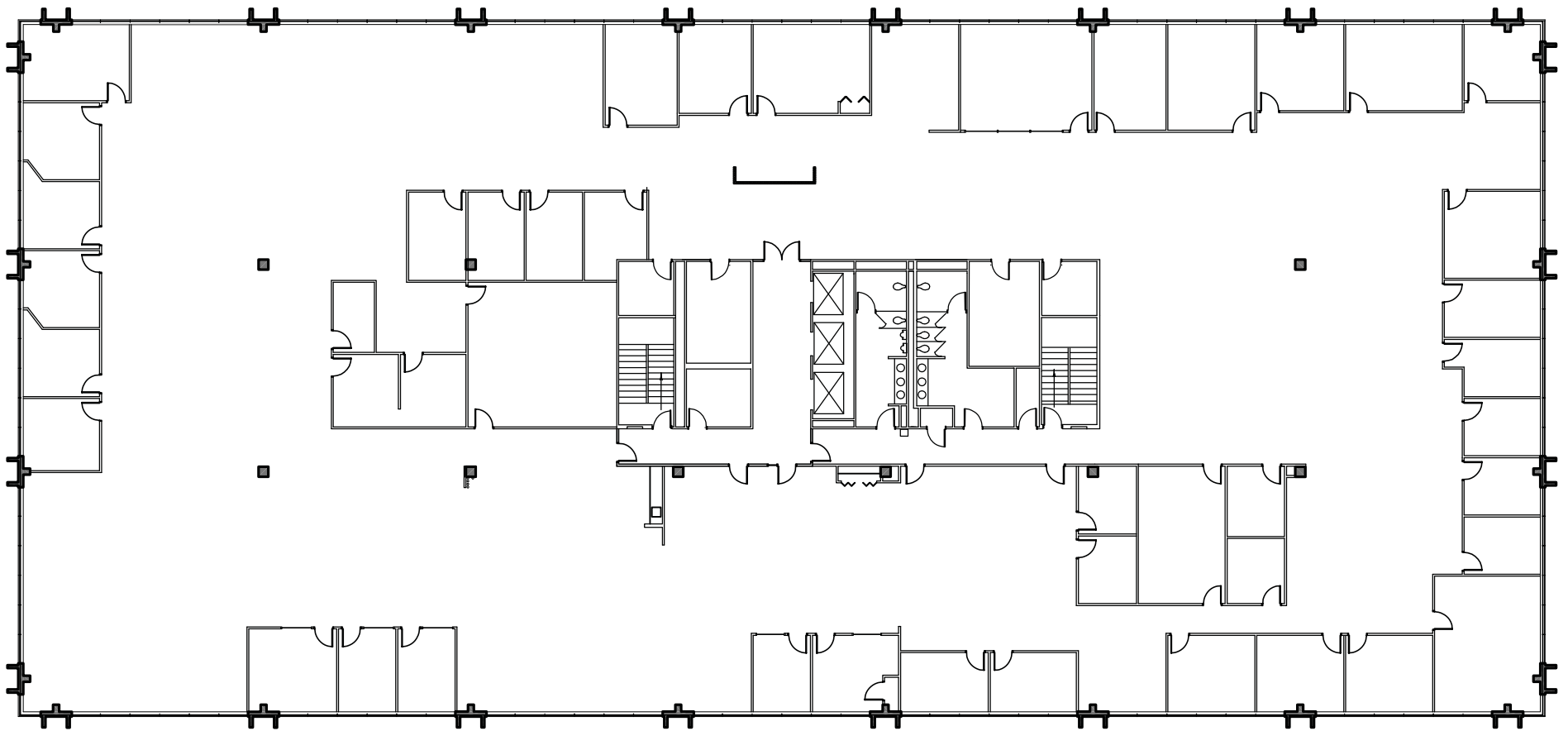

# FIFTH FLOOR

## SUITE 550

9,206 SF AVAILABLE

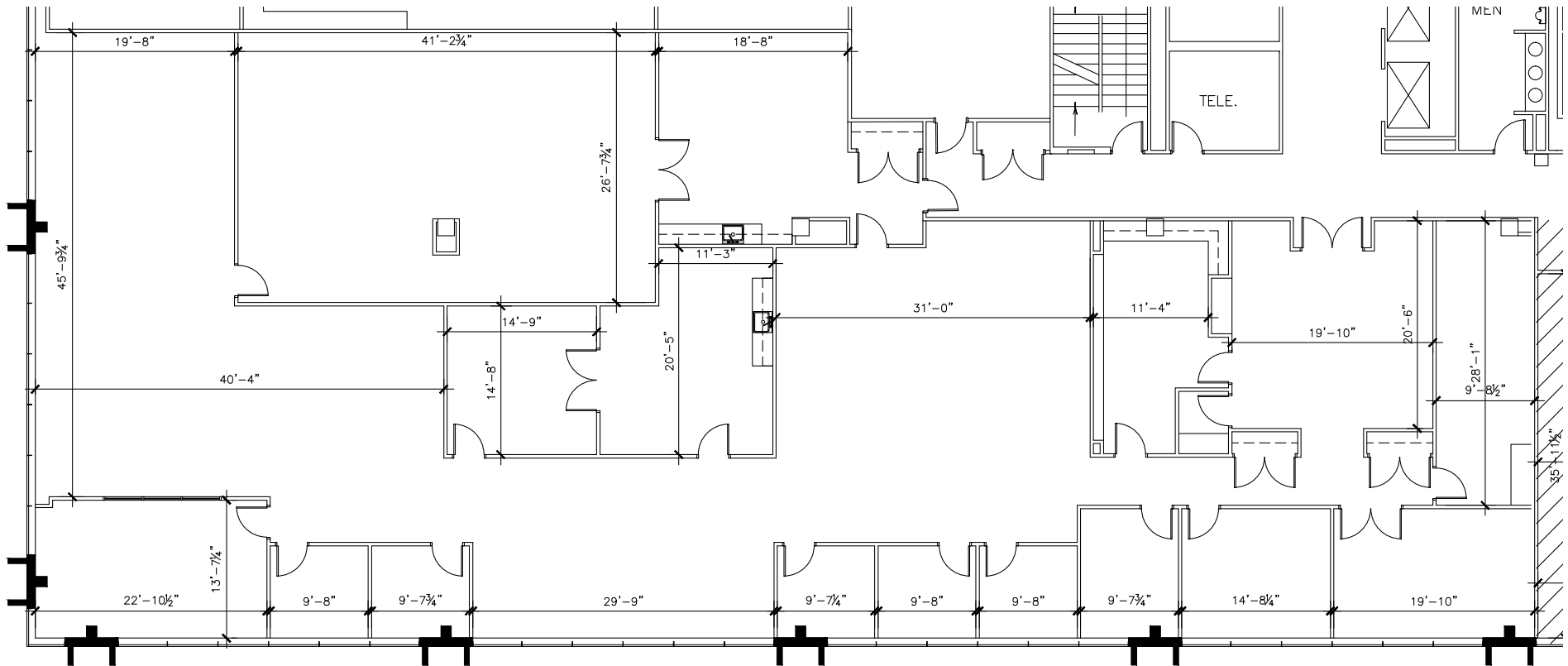



# FIFTH FLOOR

## SUITE 560

2,226 SF AVAILABLE

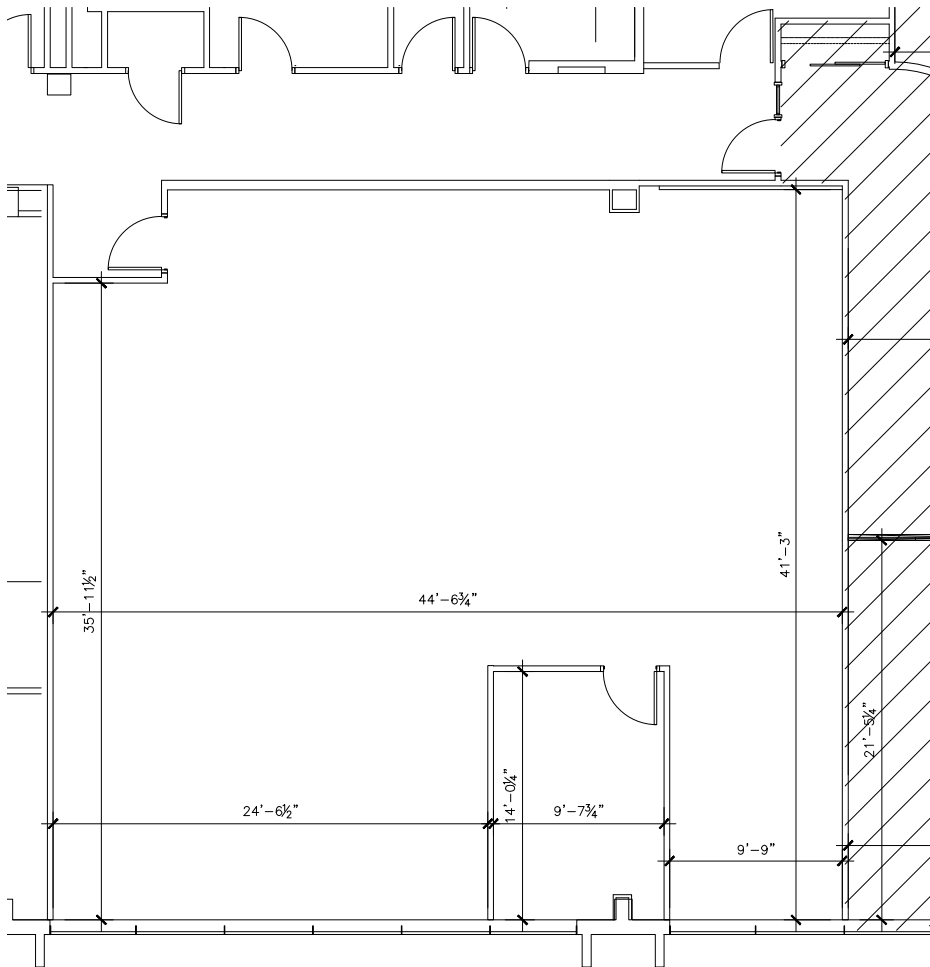





*For more information, please contact:*

**TONY RUSSO**

Senior Vice President

630.728.1179

[trusso@lee-associates.com](mailto:trusso@lee-associates.com)

**GRANT BOLLMAN**

Vice President

708.420.9996

[gbollman@lee-associates.com](mailto:gbollman@lee-associates.com)



9450 W. Bryn Mawr Ave.  
Suite 550 | Rosemont, IL 60018  
[www.lee-associates.com](http://www.lee-associates.com)