

ALL WORK TO CONFORM WITH THE 2021 IBC CODE

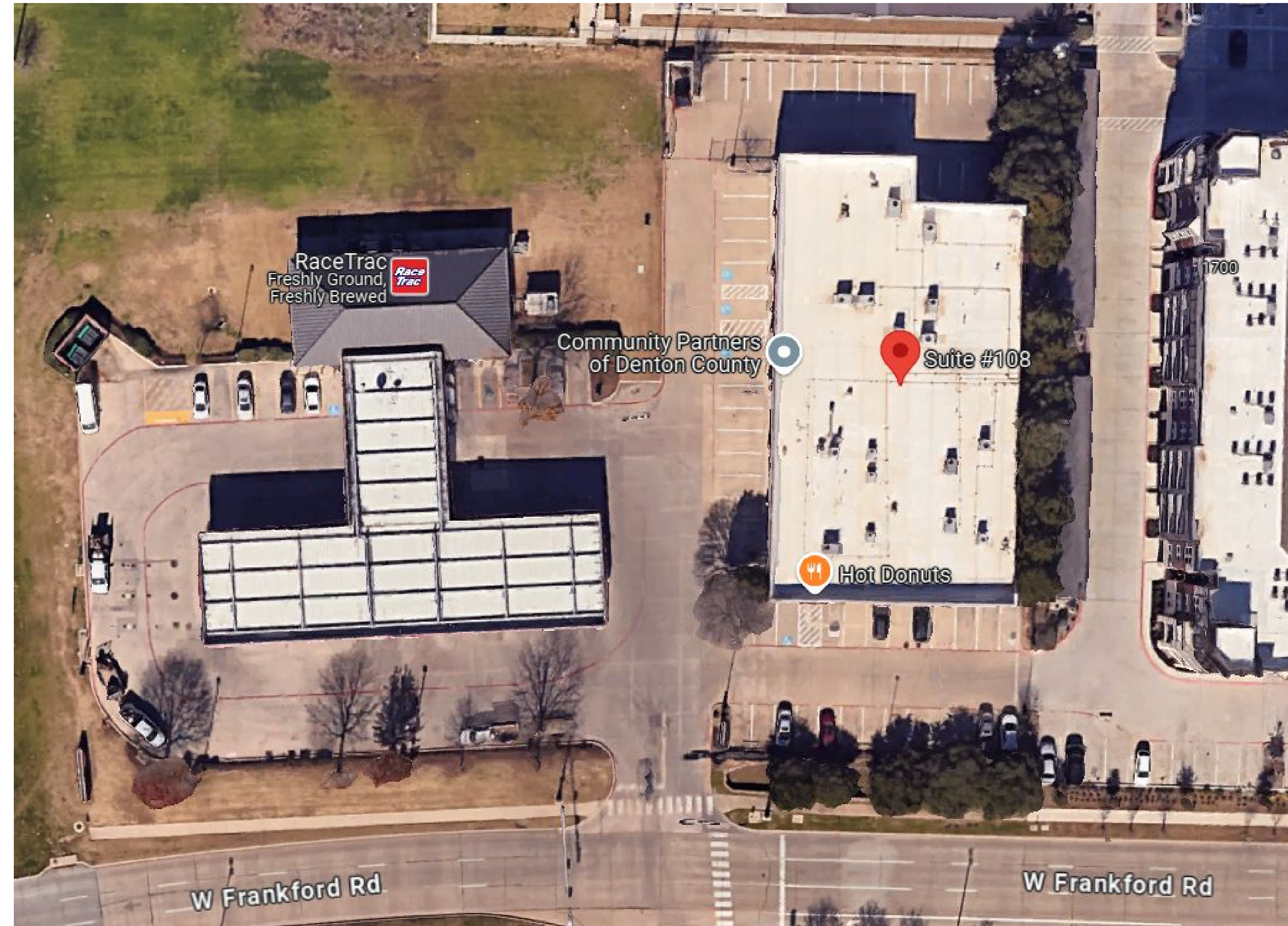

LEASE FINISHOUT	
LEGAL DESCRIPTION	EMPTY SPEC SPACE
ADDRESS	1712 W. FRANKFORD ROAD SUITE 108-A CARROLLTON, TEXAS 75007
DESIGN CRITERIA	2021 ICC CODE STANDARDS, 2020 NEC, IBC, IECC, IMC, IPC, IFGC AND IFC WITH AMENDMENTS
CODE ANALYSIS	OCCUPANCY: TO BE DETERMINED SPRINKLER EXISTING IN PLACE CONSTRUCTION TYPE: V-B ALLOWABLE AREA: M: 1,805 SF
PROPOSED AREA:	M: 1,805 SF
CONSTRUCTION TYPE:	V-B (COMBUSTABLE CONSTRUCTION, UNPROTECTED)
OCCUPANCY LOAD:	RETAIL - 1 PER 60 SF GROSS FLOOR AREA TO BE DETERMINED
EXIT ACCESS:	PER SECTION 1017 IS EXIT ACCESS DISTANCE, 200' IS MAX ALLOWABLE FOR SPRINKLERED OCCUPANCY TWO EXIT DOORS PER UNIT, 36" ENTRY DOORS
ADA / TLDR REVIEW:	TABS 2023025360

Texas Mart Associates, LLC	
1712 W. Frankford Road Suite 108-A Carrollton, Texas 75007	
Jim Hill Designs	
2909 E. Arkansas Lane Suite C-558 Arlington, Texas 76010 (214) 973-0186 Cell JIMHILLDESIGNS@GMAIL	
SCALE: 3/16" = 1'-0" U.O.N.	
PAGE:	DATE: 9/04/2024
FILE NAME: 1712 SUITES-1AEC	

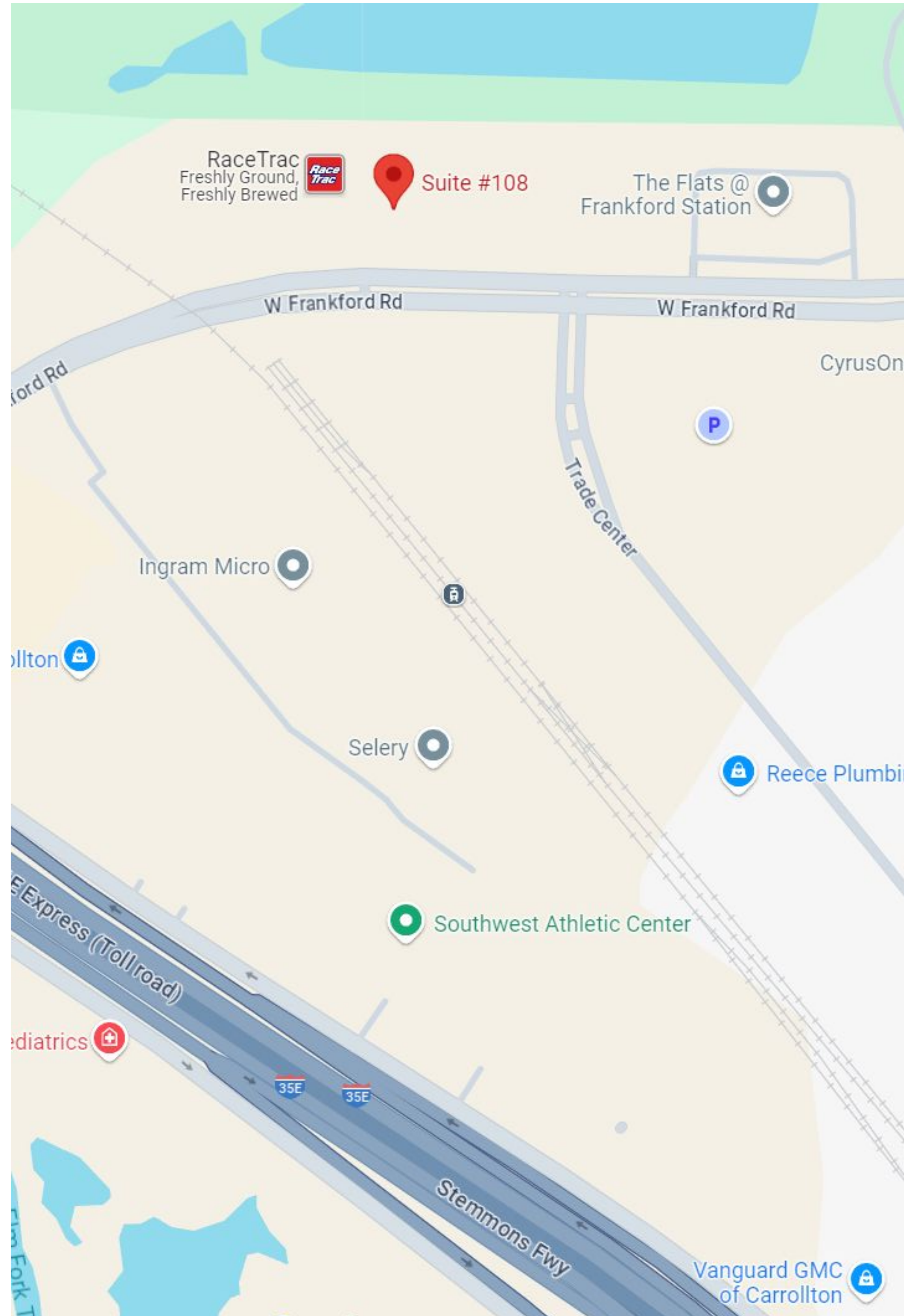
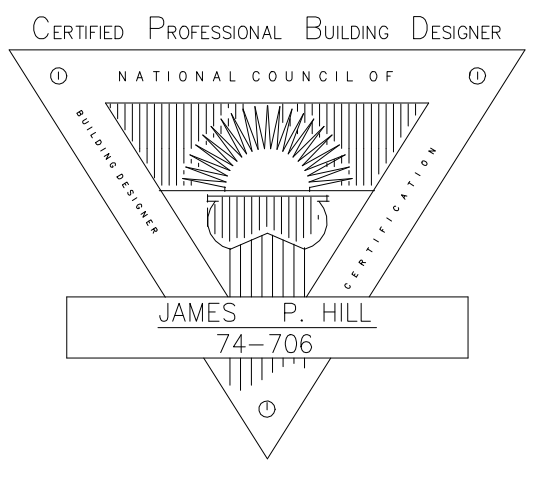
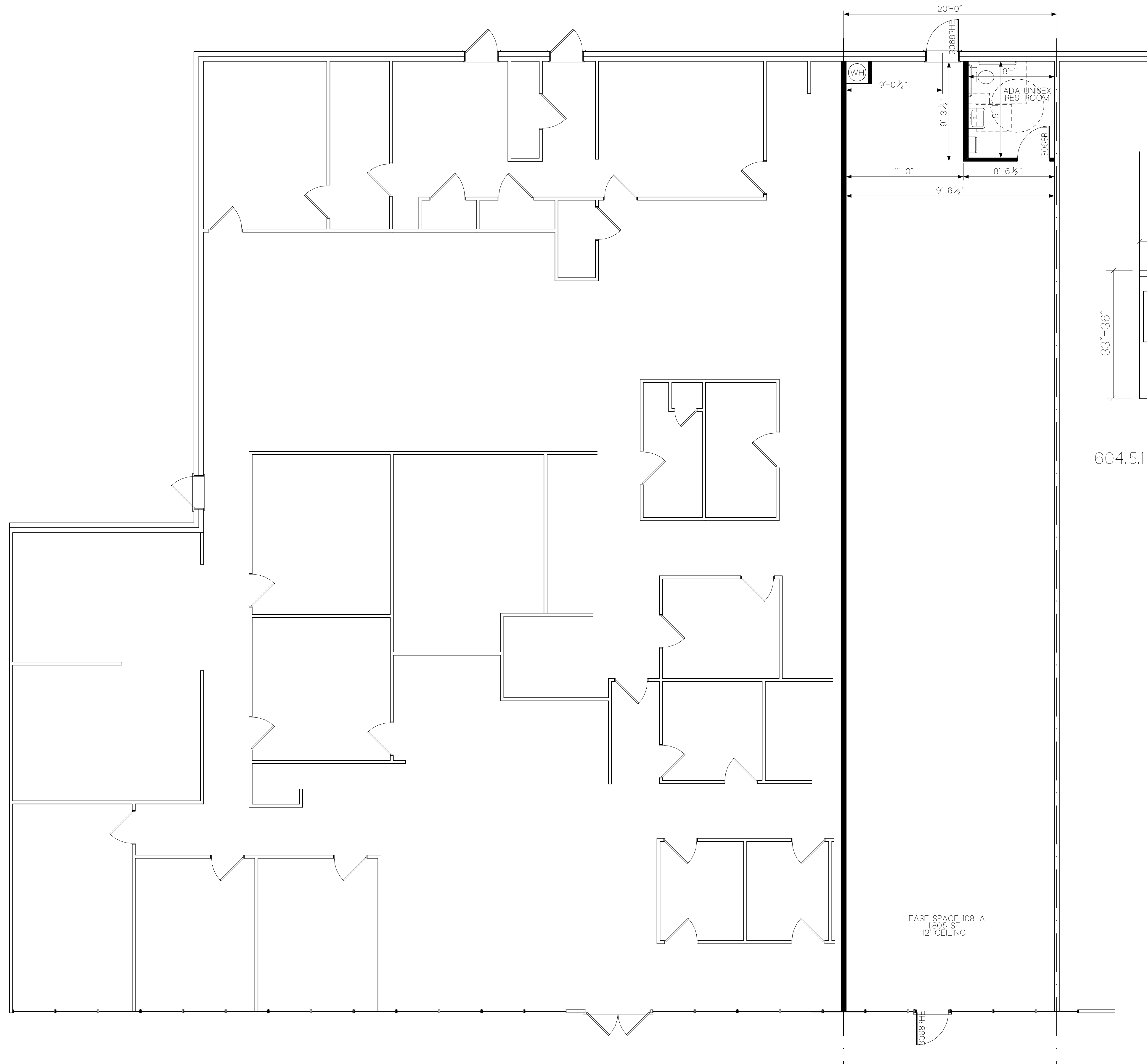
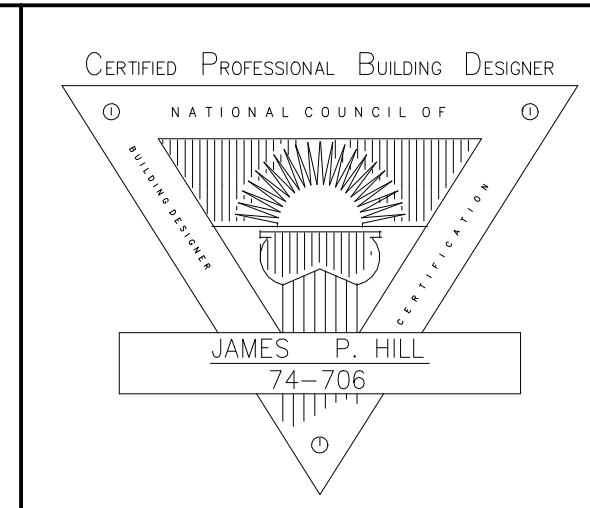

NEW PLAN

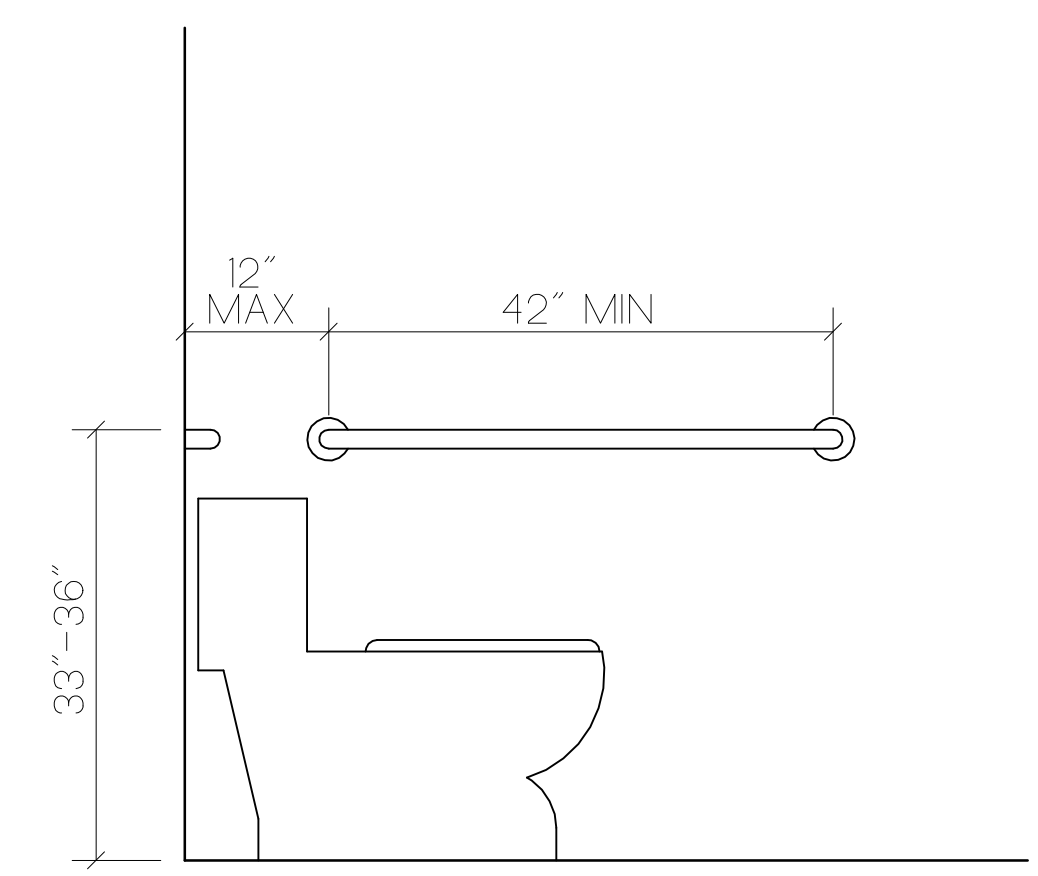

604.5.1 Side Wall Grab Bar at Water Closets

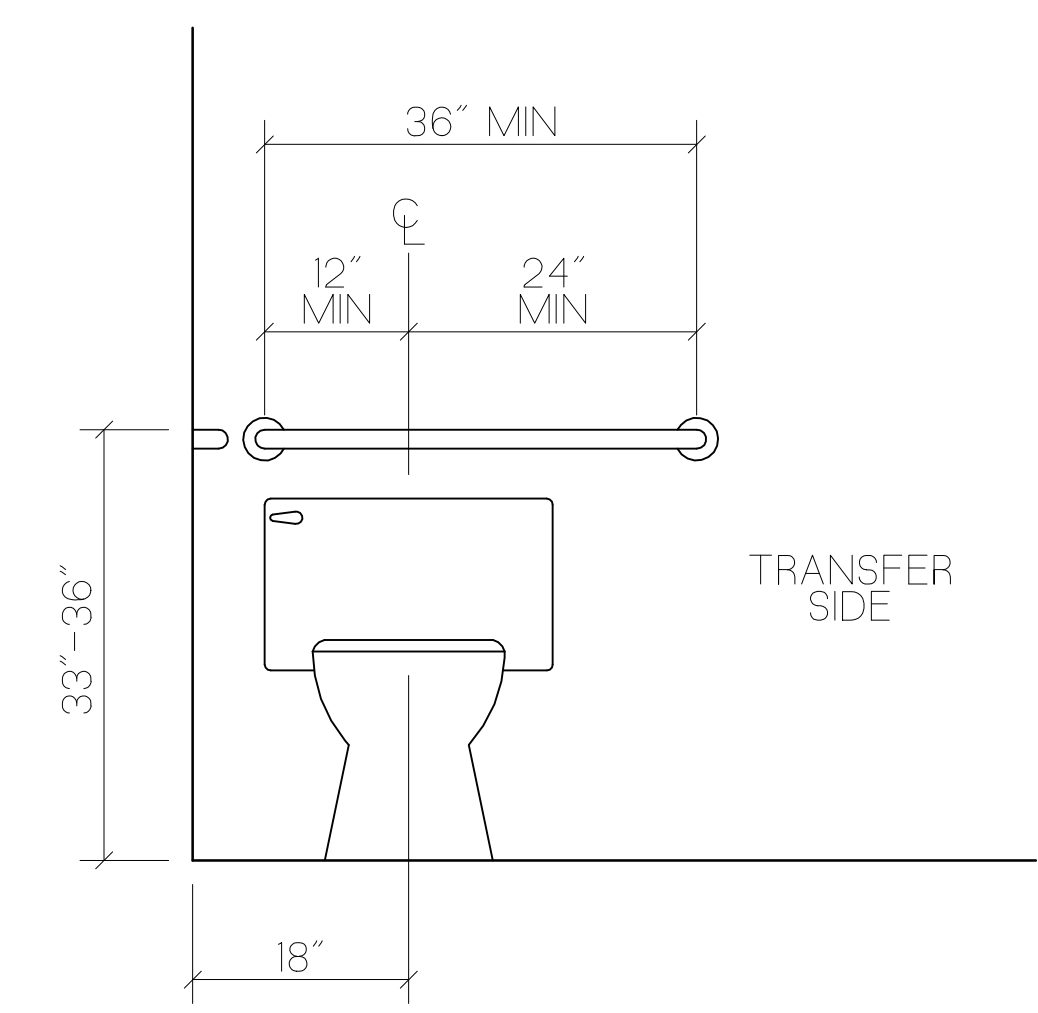

604.5.2 Rear Wall Grab Bar at Water Closets

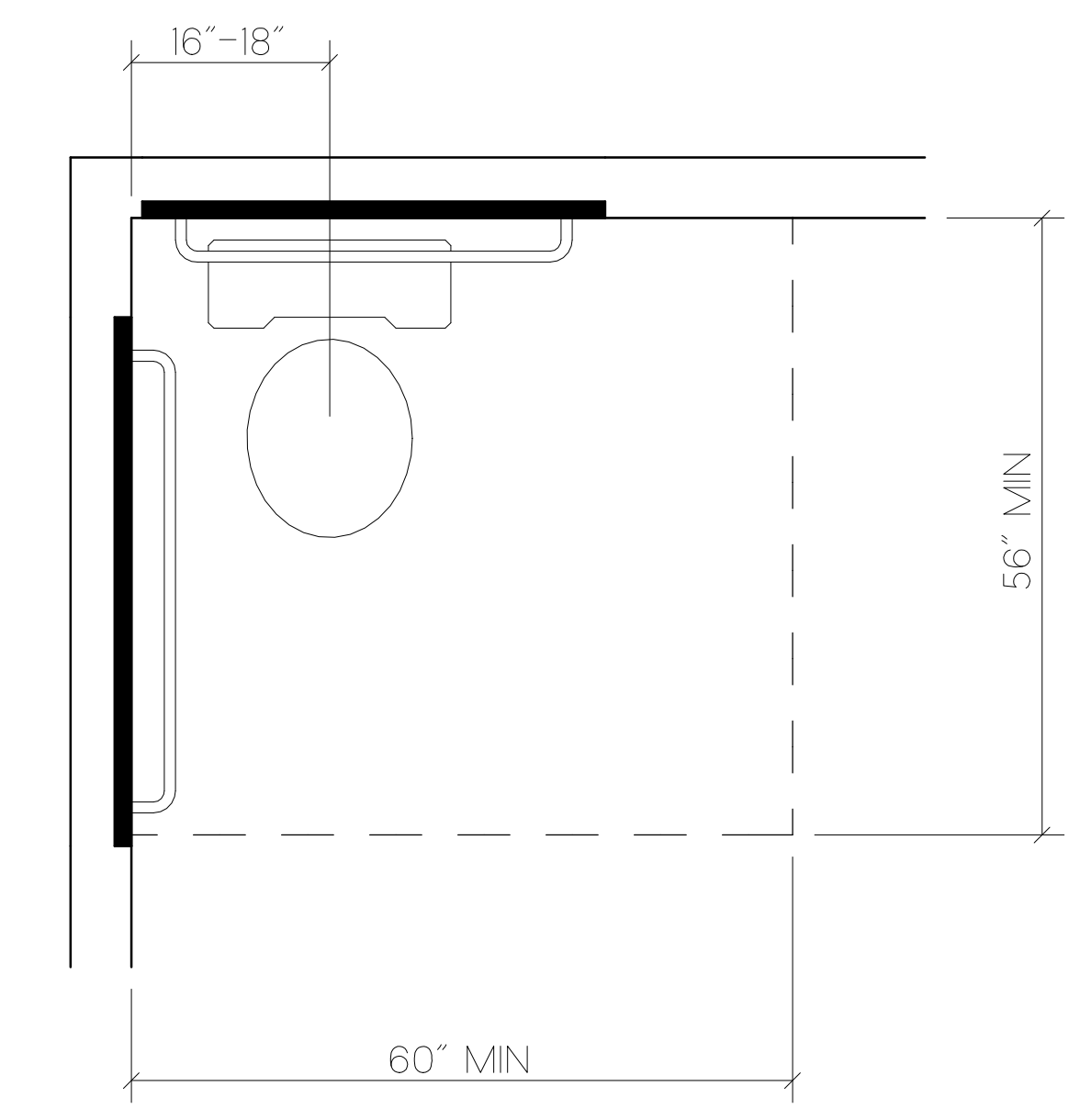

604.3.1 Side of Clearance at Water Closets

Texas Mart Associates, LLC
 1712 W. Frankford Road
 Suite 108-A
 Carrollton, Texas 75007

Jim Hill Designs
 2909 E. Arkansas Lane
 Suite C-558
 Arlington, Texas 76010
 (214) 973-0186 Cell
 JIMHILLDESIGNS@GMAIL

SCALE:
 3/16" = 1'-0" U.O.N.

PAGE: DATE:
 9/04/2024

FILE NAME:
 1712 SUITES-IAEC

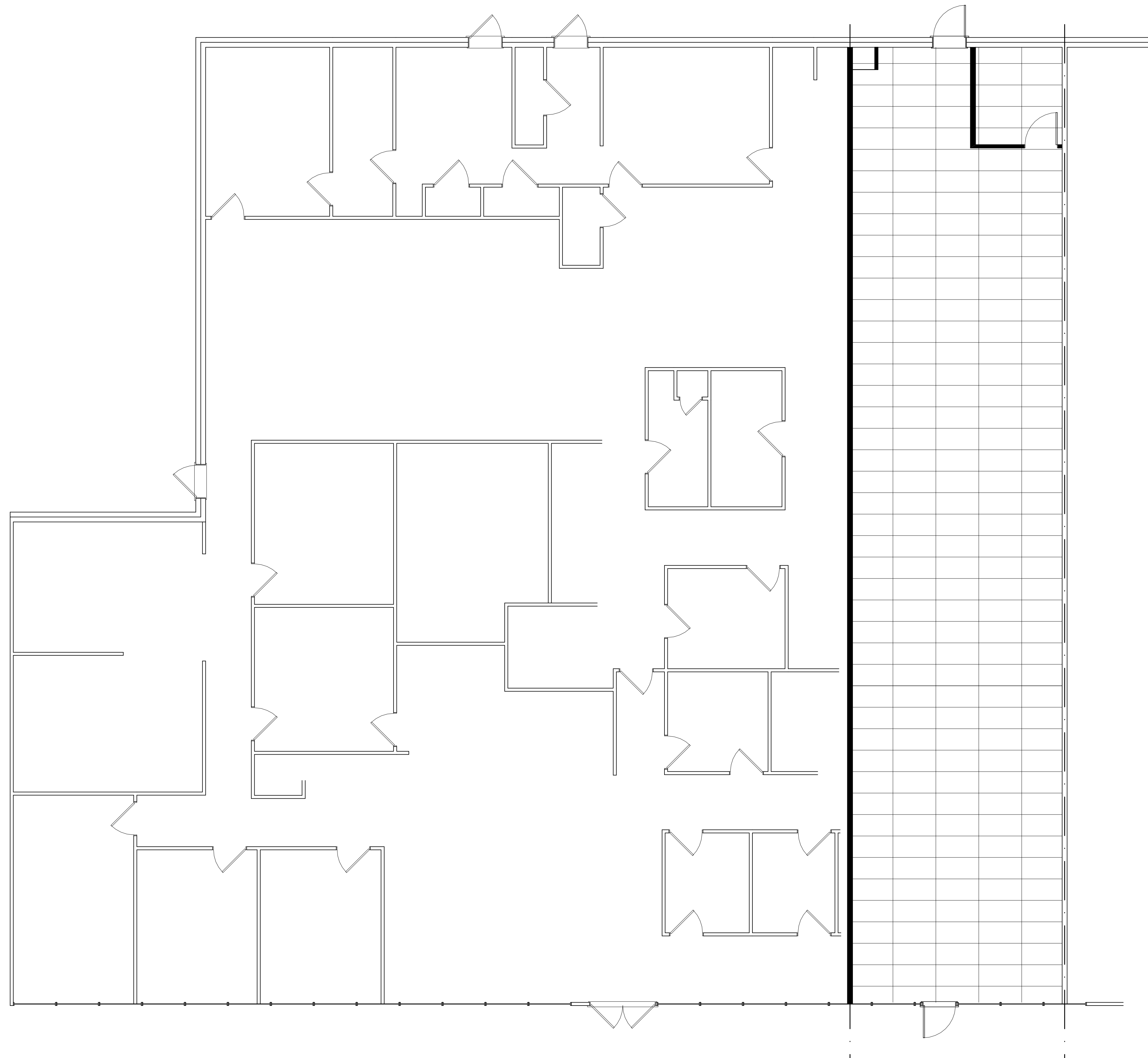
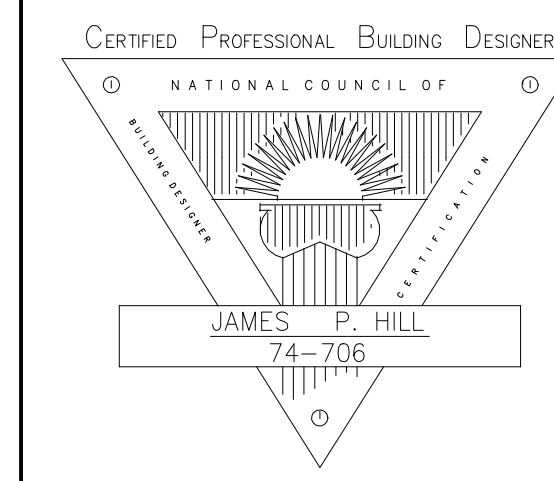

REFLECTIVE CEILING PLAN

Texas Mart Associates, LLC 1712 W. Frankford Road Suite 108-A Carrollton, Texas 75007	
Jim Hill Designs 2909 E. Arkansas Lane Suite C-558 Arlington, Texas 76010 (214) 973-0186 Cell JIMHILLDESIGNS@GMAIL	
SCALE: 3/16" = 1'-0" U.O.N.	
PAGE:	DATE: 9/04/2024
FILE NAME: 1712 SUITES-IAEC	

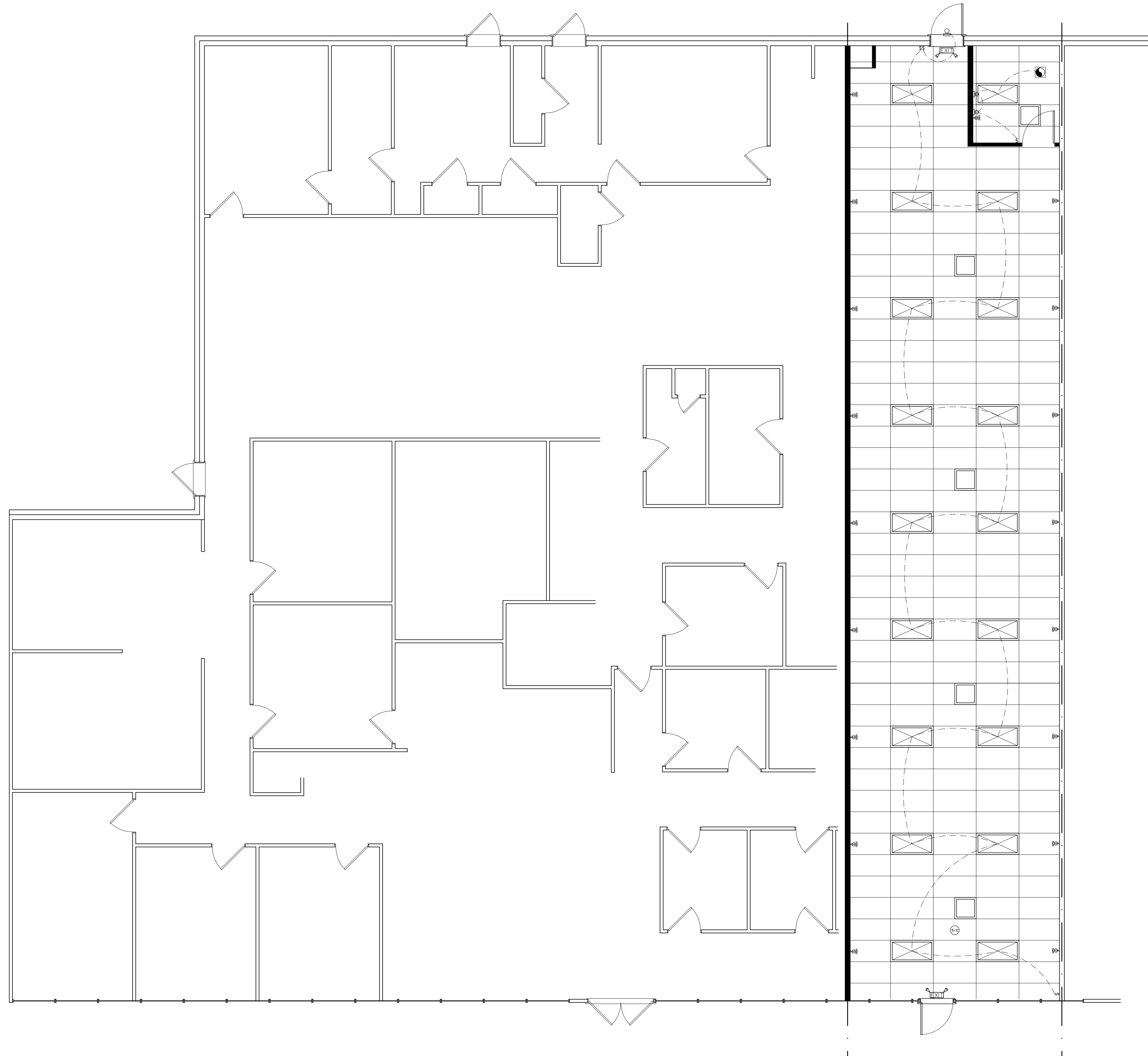
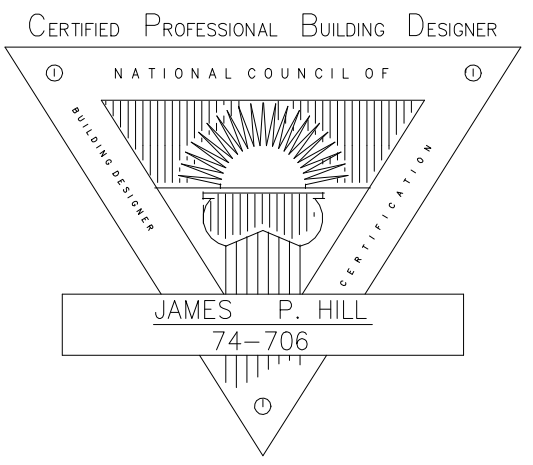

LIGHTING / ELECTRICAL PLAN

Texas Mart Associates, LLC
1712 W. Frankford Road
Suite 108-A
Carrollton, Texas 75007

Jim Hill Designs
2909 E. Arkansas Lane
Suite C-558
Arlington, Texas 76010
(214) 973-0186 Cell
JIMHILLDESIGNS@GMAIL

SCALE:
3/16" = 1'-0" U.O.N.

PAGE: DATE:
 9/04/2024

FILE NAME:
1712 SUITES-1AEC

ALL WORK TO CONFORM WITH THE 2021 IBC CODE

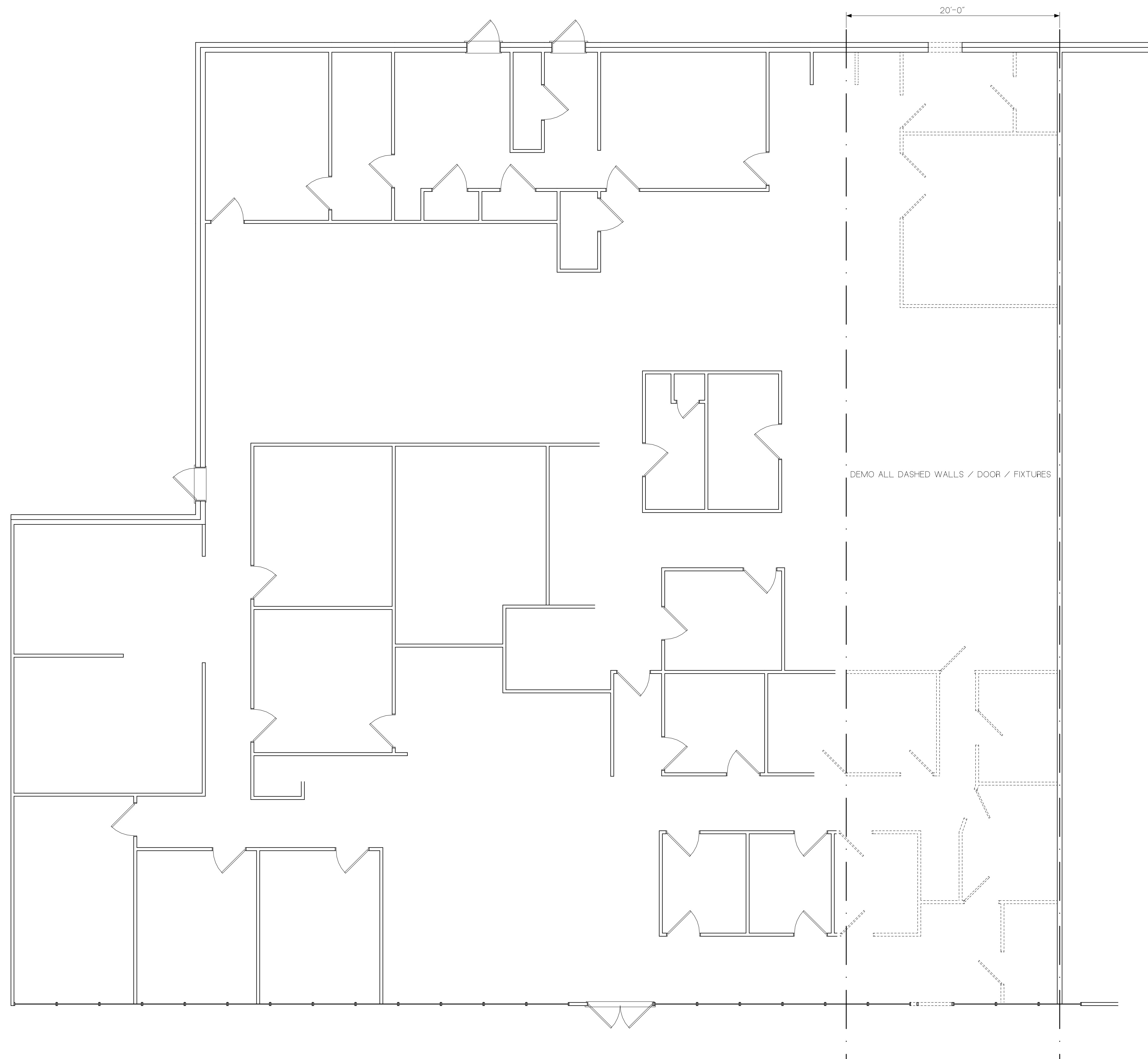
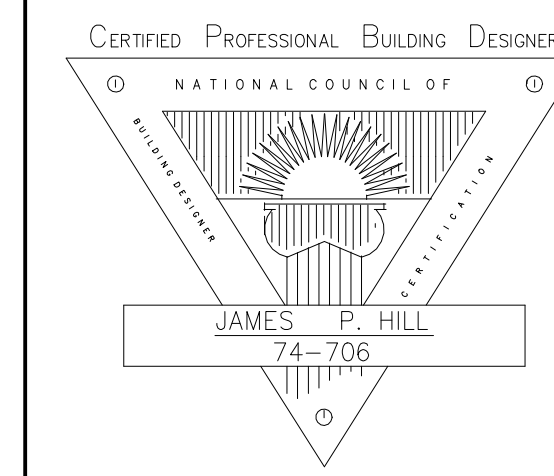

DEMO PLAN

Texas Mart Associates, LLC
1712 W. Frankford Road
Suite 108-A
Carrollton, Texas 75007

Jim Hill Designs
2909 E. Arkansas Lane
Suite C-558
Arlington, Texas 76010
(214) 973-0186 Cell
JIMHILLDESIGNS@GMAIL

SCALE:
3/16" = 1'-0" U.O.N.

PAGE:	DATE:
	9/04/2024

FILE NAME:
1712 SUITES-1AEC