

215 INTERNATIONAL DRIVE

CONCORD, NC



PROPERTY HIGHLIGHTS

- » Prime accessibility and visibility at signalized interchange of Poplar Tent Road and International Drive
- » Immediate Access from I-85 via Poplar Tent Road (Exit 52), Highway 73 (Exit 55) or George Liles Parkway (Exit 54)
- » Adjacent to International Business Park with respected and established corporations, including Sysco Foods, FedEx, Celgard and Legrand.

CONTACT

Terry Brennan | 704.575.2497 | tjb@trinity-partners.com

Bill Wood | 704.906.2763 | wpw@trinity-partners.com

OWNED BY

INDUS
INDUS REALTY TRUST

LEASED BY

TRINITY
PARTNERS

BUILDING DATA

CONSTRUCTION TYPE:	Tilt Wall
DEPTH:	240'
COLUMN SPACING:	45' x 50'
STAGING BAY:	50' x 60'
CLEAR HEIGHT:	32'
SPRINKLER SYSTEM:	ESFR
DOCK DOORS:	27 (capacity for additional)
DRIVE-IN DOORS:	1
TRUCK COURT:	130'
VEHICULAR PARKING:	172
ROOF SYSTEM:	TPO 45 mil Roof
TRUCK COURT:	130' Fenced and Gated

AVAILABILITY

TOTAL BUILDING SF:	277,253 SF
AVAILABLE SPACE:	277,253 SF (Divisible)
OFFICE SPACE:	7,335 SF in 3 Pods

FEATURES

- » Immediately adjacent to International Business Park
- » Double diverging diamond intersections at Poplar Tent Road/I-85 exit and Hwy 73/I-85 exit
- » T5 lighting in warehouse
- » Two (2) 100 KV substations serving area and another 100 KV substation 5 miles away
- » Three separate office pods in place

UTILITIES AVAILABLE

ELECTRIC:	City of Concord Electric
GAS:	PSNC Energy
WATER AND SEWER:	City of Concord



CONTACT

Terry Brennan | 704.575.2497 | tjb@trinity-partners.com
Bill Wood | 704.906.2763 | wpw@trinity-partners.com

OWNED BY

INDUS
INDUS REALTY TRUST

LEASED BY

TRINITY
PARTNERS

215 INTERNATIONAL DRIVE | CONCORD, NC



CONTACT

Terry Brennan | 704.575.2497 | tjb@trinity-partners.com

Bill Wood | 704.906.2763 | wpm@trinity-partners.com

OWNED BY

INDUS
INDUS REALTY TRUST

LEASED BY

TRINITY
PARTNERS

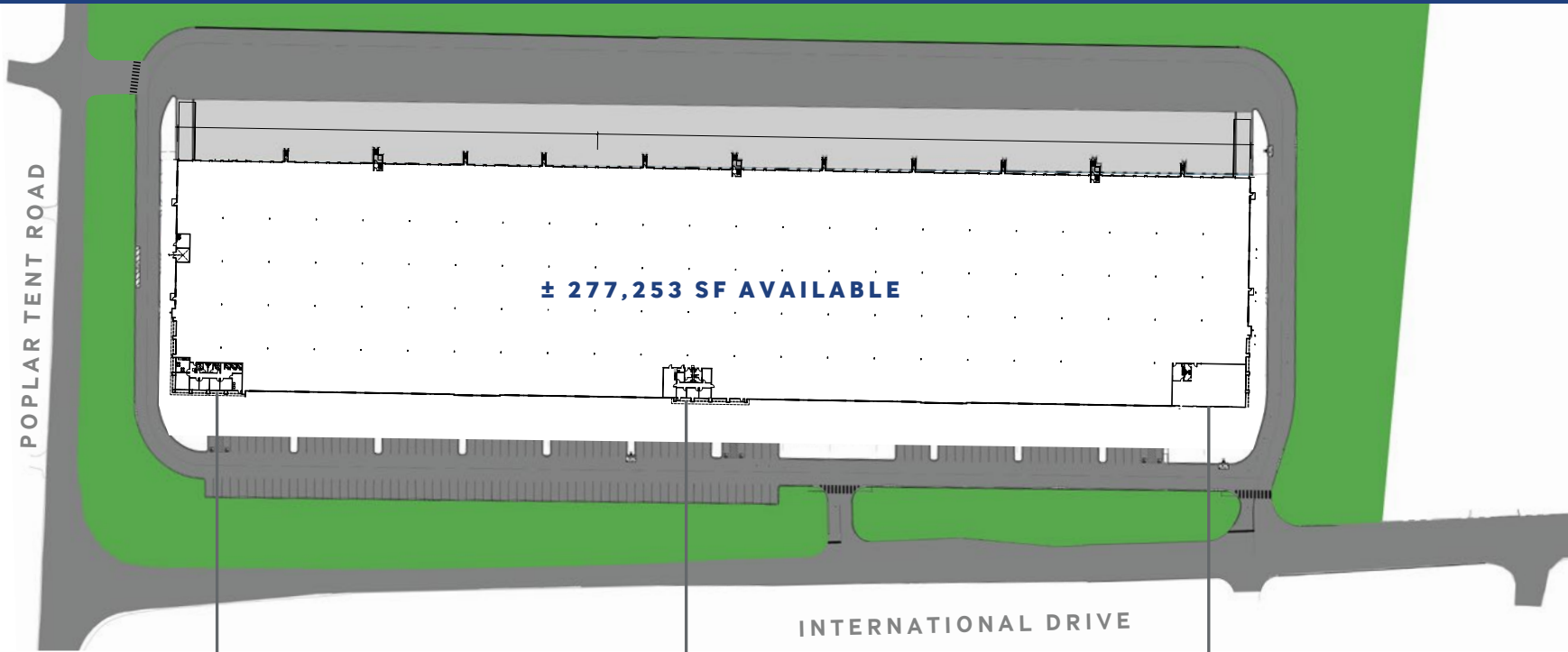

IN-PLACE OFFICE BUILDOUTS

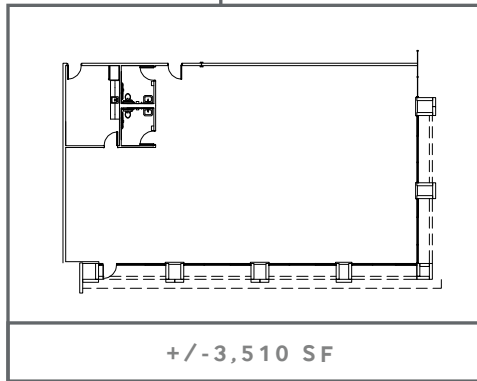
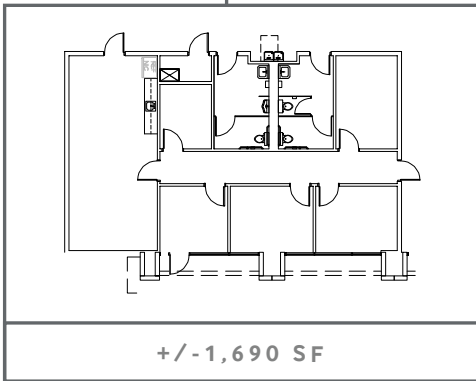
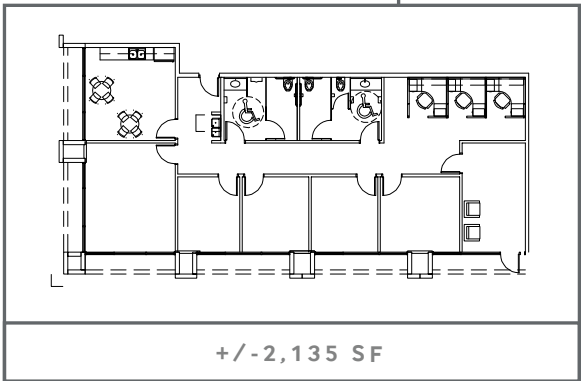

CONTACT

Terry Brennan | 704.575.2497 | tjb@trinity-partners.com
Bill Wood | 704.906.2763 | wpw@trinity-partners.com

OWNED BY
INDUS
INDUS REALTY TRUST

LEASED BY
TRINITY
PARTNERS