



Sterling Business Center

Emily Bynum

Direct 318.698.1106
Mobile 318.272.4026
EmilyB@Sealynet.com

Joe Fleming, LA & TX Licensed Broker Agent

Direct 318.698.1108
Mobile 318.465.0930
JoeF@Sealynet.com

Sealy Real Estate Services

333 Texas Street, Suite 1050
Shreveport, LA 71101

318.222.8700
www.sealynet.com



Property Highlights

- Ideally Located with Close Proximity to I-49, I-20, I-220, and Shreveport Regional Airport
- Situated Within South Shreveport's Medical District
- Highly Visible Signage and Easy Business Center Access
- Ample Parking
- Suites Individually Climate Controlled
- Local Professional Management
- Flexible Suite Configurations

Property Overview

Sterling Business Center is the premier commercial property in southwest Shreveport offering professional management, excellent signage, a variety of space sizes, ample parking, easy access, and competitive lease terms. Taxes, insurance and CAM are budgeted to be \$5.51 SF/yr. Electricity is separately metered.

Sealy Real Estate Services
333 Texas Street, Suite 1050
Shreveport, LA 71101
318.222.8700
www.sealynet.com

Emily Bynum
Direct 318.698.1106
Mobile 318.272.4026
EmilyB@Sealynet.com

Joe Fleming, LA & TX Licensed Broker Agent
Direct 318.698.1108
Mobile 318.465.0930
JoeF@Sealynet.com

All information set forth in this brochure has been obtained from the owner, personal observation, or other reliable sources. Sealy Real Estate Services, LLC does not guarantee the accuracy of this information and makes no representations or warranties, expressed or implied, in this brochure. Information contained herein is subject to change without notice.

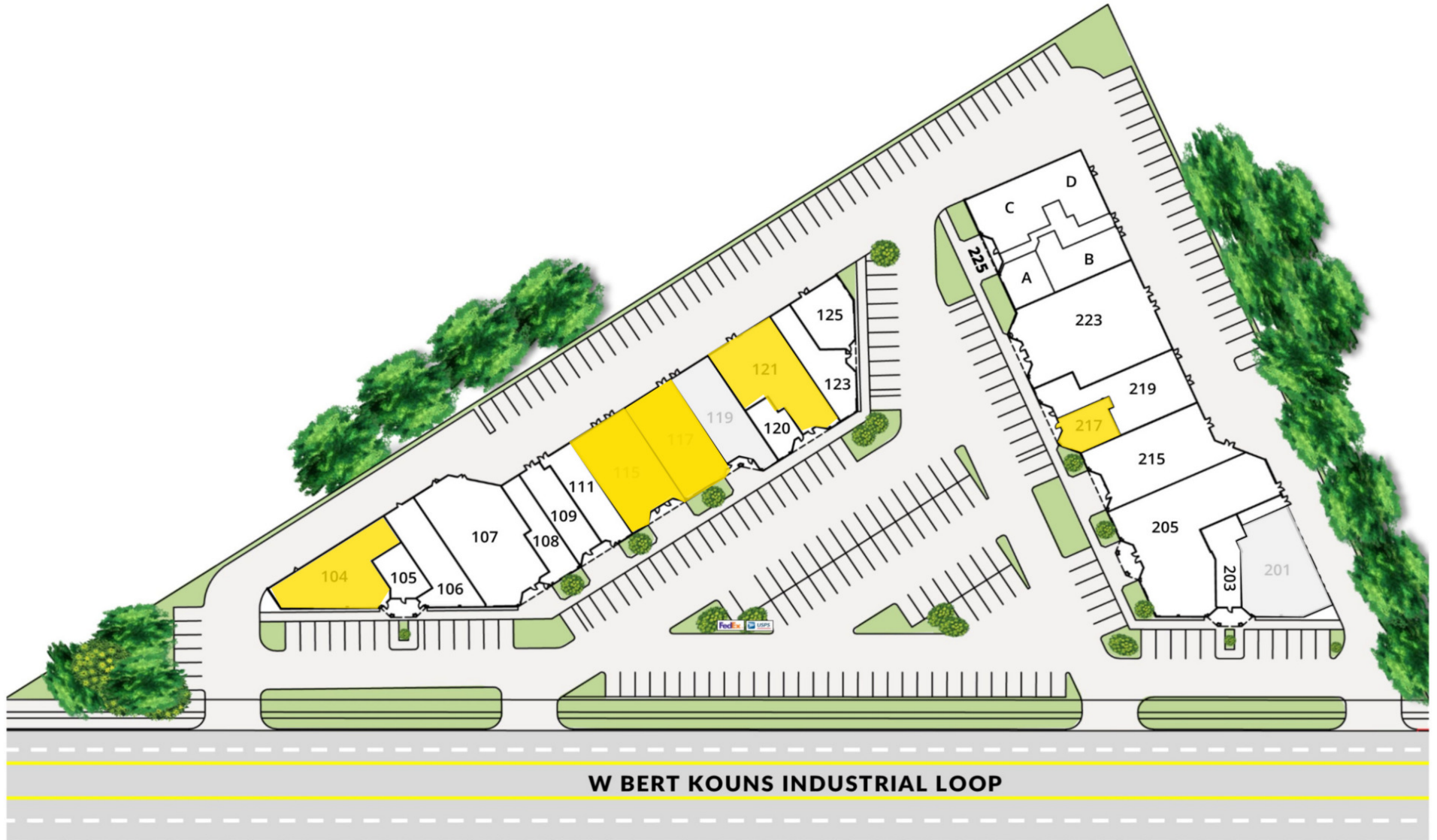

Sealy Real Estate Services
333 Texas Street, Suite 1050
Shreveport, LA 71101
318.222.8700
www.sealynet.com

Emily Bynum
Direct 318.698.1106
Mobile 318.272.4026
EmilyB@Sealynet.com

Joe Fleming, LA & TX Licensed Broker Agent
Direct 318.698.1108
Mobile 318.465.0930
JoeF@Sealynet.com

All information set forth in this brochure has been obtained from the owner, personal observation, or other reliable sources. Sealy Real Estate Services, LLC does not guarantee the accuracy of this information and makes no representations or warranties, expressed or implied, in this brochure. Information contained herein is subject to change without notice.

Lease Information

Lease Type:	NNN	Lease Term:	Negotiable
Total Space:	14,884 SF	Lease Rate:	\$13.50 - \$15.50 SF/yr

Available Spaces

	Suite	Size	Type	Rate
■	104	2,587 SF	NNN	\$13.50 SF/yr
■	115	2,869 SF	NNN	\$13.50 SF/yr
■	115 -117	891 - 5,326 SF	NNN	\$14.25 SF/yr
■	117	2,457 SF	NNN	\$15.50 SF/yr
■	121	2,925 SF	NNN	\$13.50 SF/yr
■	217	891 SF	NNN	\$15.50 SF/yr

2533 BERT KOUNS, SUITE 104
2,587 SQUARE FEET
FOR LEASE

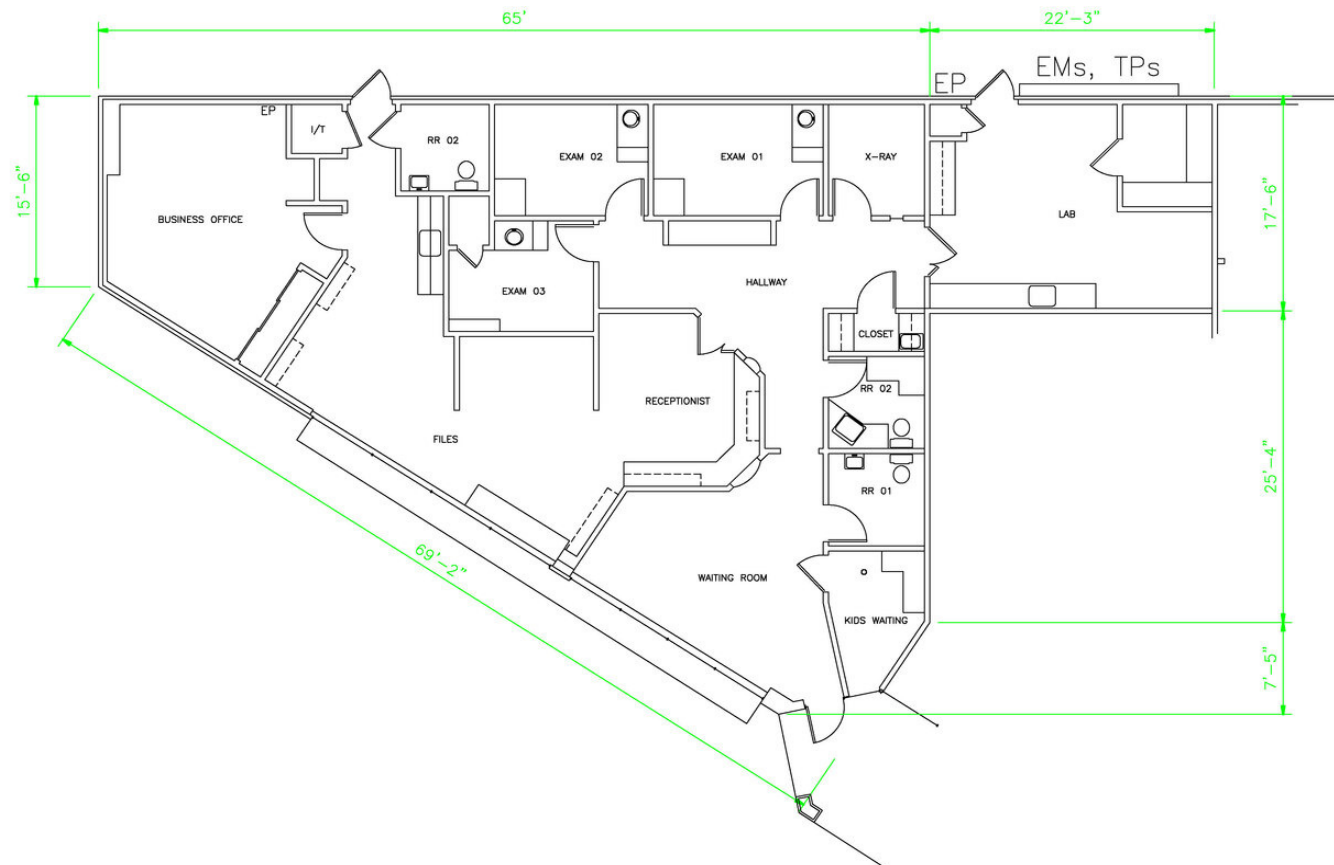

**Suite 115
2,869 SF**

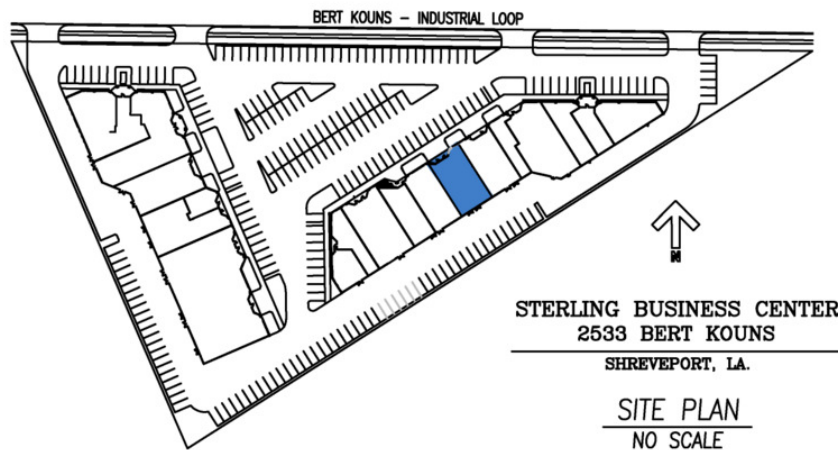

ALL INFORMATION IS SUBJECT TO CHANGE.

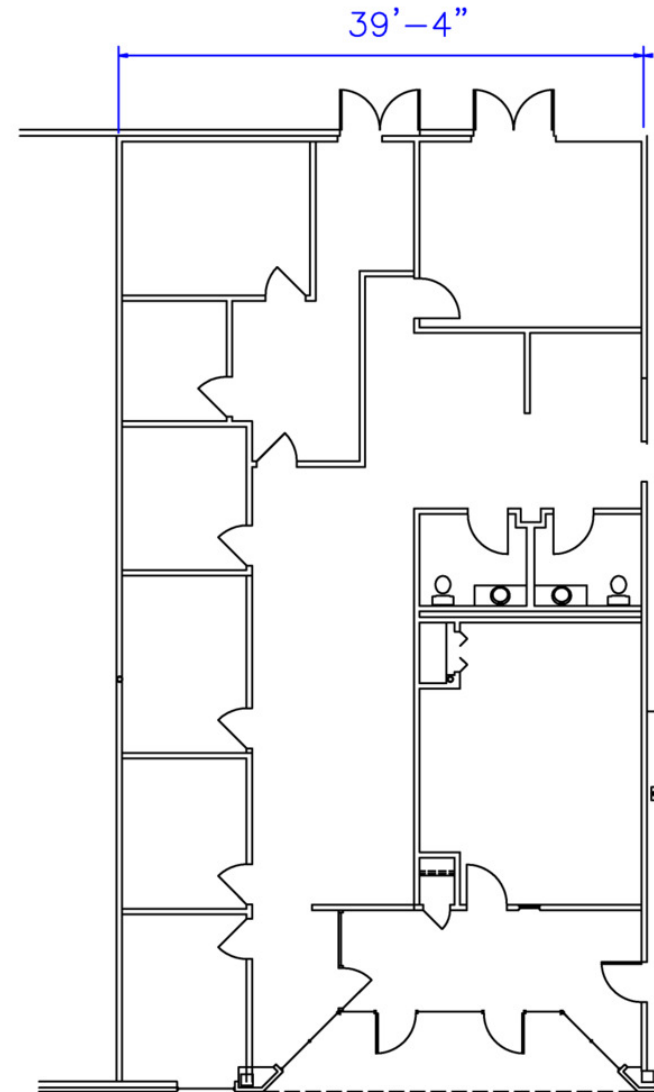

**Suite 117
2,457 SF**

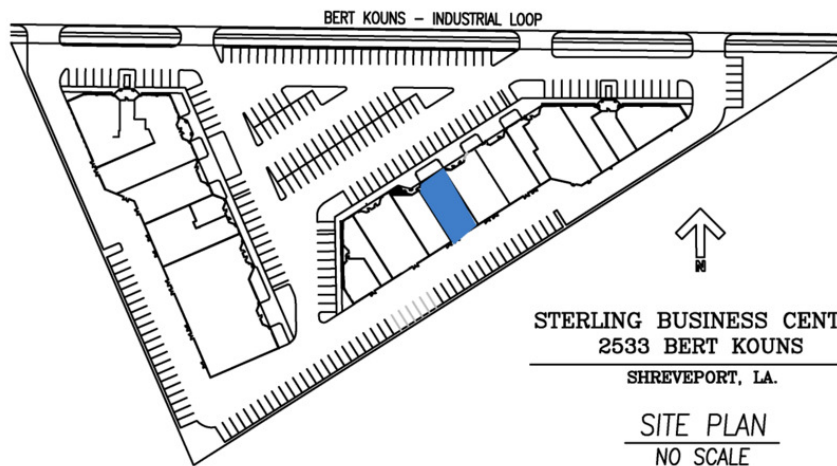

ALL INFORMATION IS SUBJECT TO CHANGE.

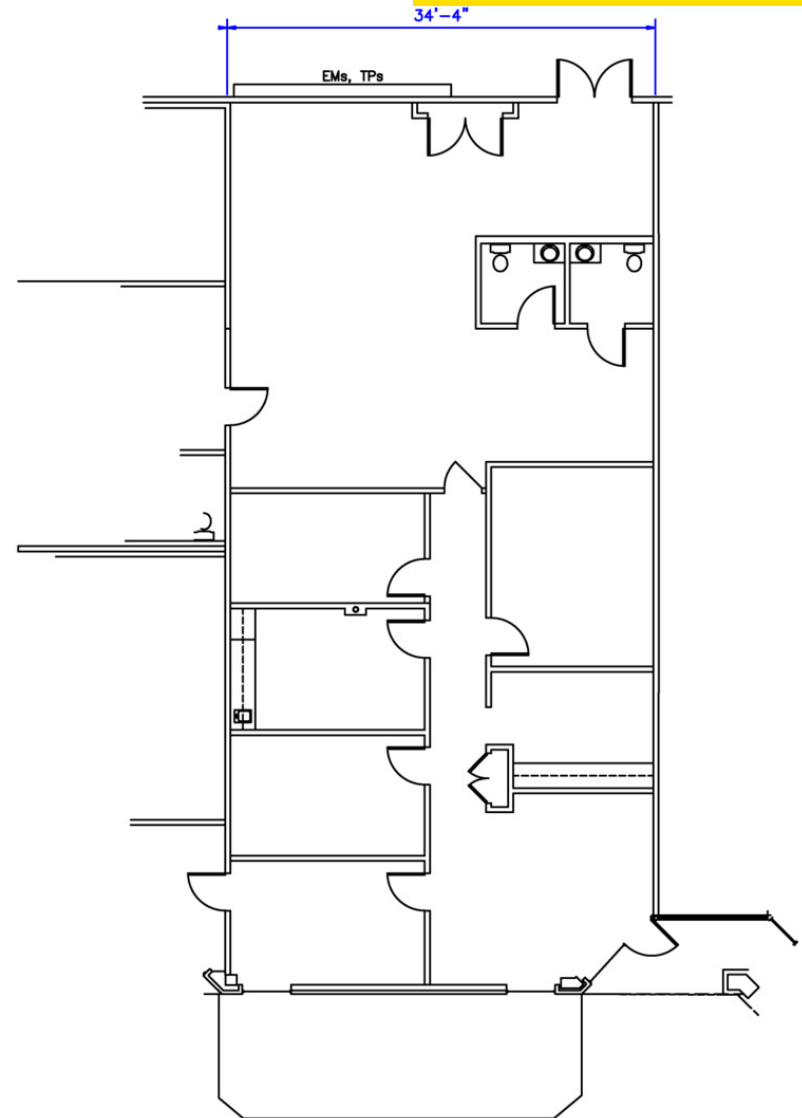

**Suite 121
2,925 SF**

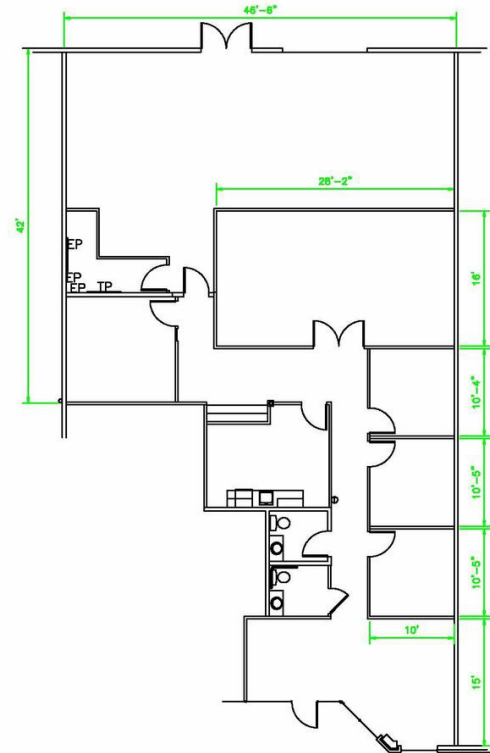

SPACE PLAN
1/16" = 1'-0"

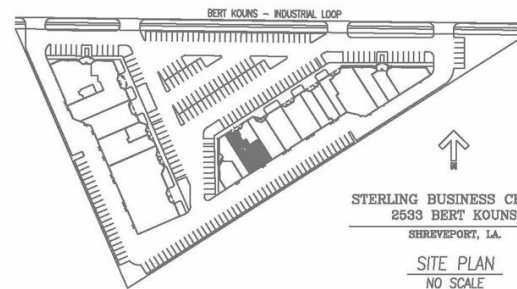

Sealy Real Estate Services
333 Texas Street, Suite 1050
Shreveport, LA 71101
318.222.8700
www.sealynet.com

Emily Bynum
Direct 318.698.1106
Mobile 318.272.4026
EmilyB@Sealynet.com

Joe Fleming, LA & TX Licensed Broker Agent
Direct 318.698.1108
Mobile 318.465.0930
JoeF@Sealynet.com

All information set forth in this brochure has been obtained from the owner, personal observation, or other reliable sources. Sealy Real Estate Services, LLC does not guarantee the accuracy of this information and makes no representations or warranties, expressed or implied, in this brochure. Information contained herein is subject to change without notice.

Suite 217

891 SF

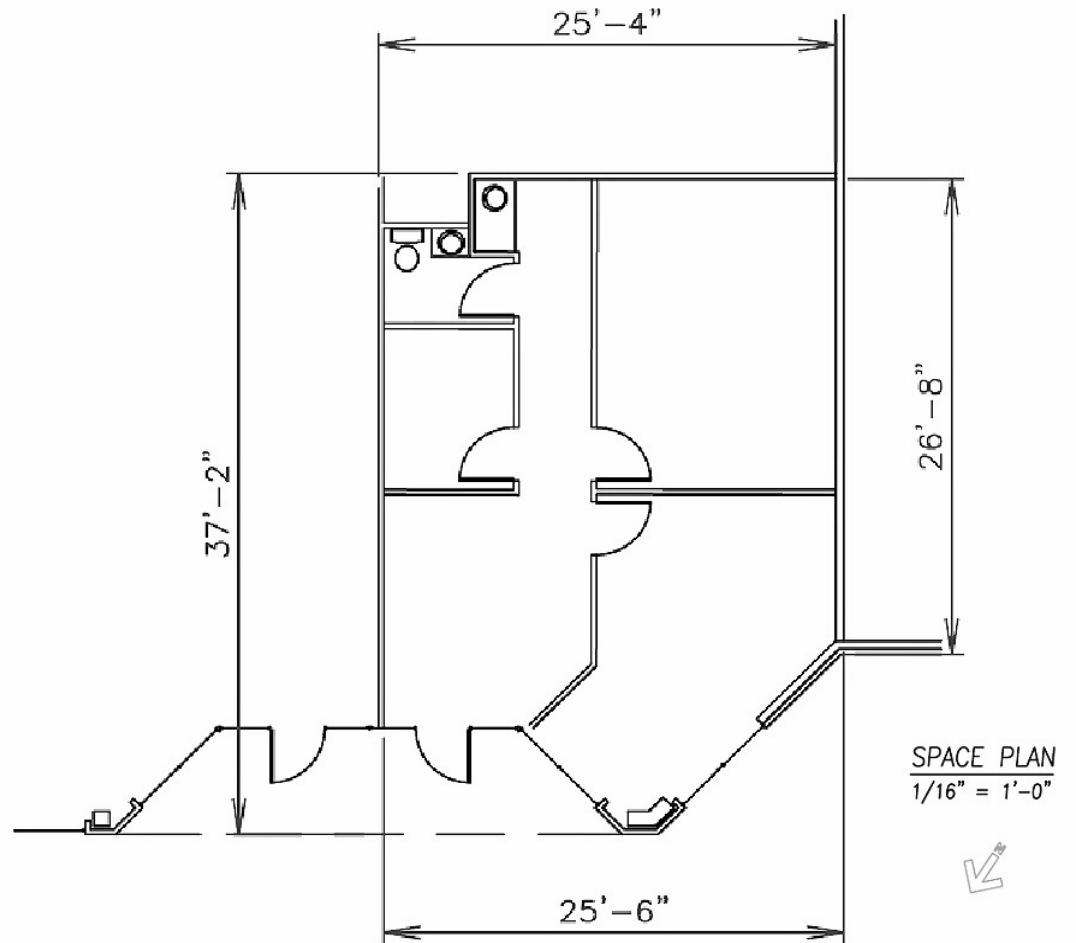
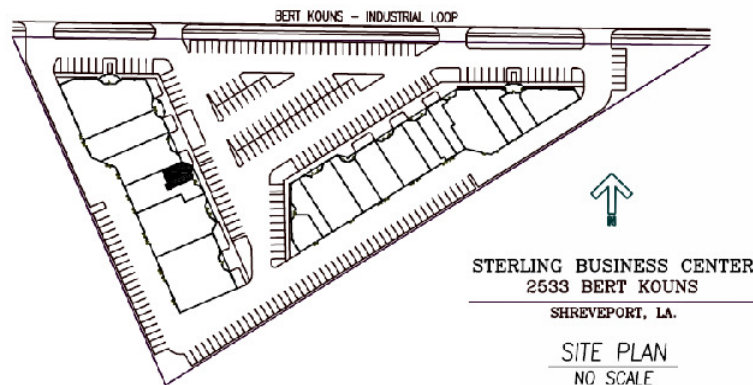



Sealy Real Estate Services
333 Texas Street, Suite 1050
Shreveport, LA 71101
318.222.8700
www.sealynet.com

Emily Bynum
Direct 318.698.1106
Mobile 318.272.4026
EmilyB@Sealynet.com

Joe Fleming, LA & TX Licensed Broker Agent
Direct 318.698.1108
Mobile 318.465.0930
JoeF@Sealynet.com

All information set forth in this brochure has been obtained from the owner, personal observation, or other reliable sources. Sealy Real Estate Services, LLC does not guarantee the accuracy of this information and makes no representations or warranties, expressed or implied, in this brochure. Information contained herein is subject to change without notice.