

For Lease

Colliers

Durham Business Park

Durham Park Boulevard
Pooler, Georgia

Sebastian Findlay, SIOR

Principal
+1 912 483 6160
sebastian.findlay@colliers.com





Property Highlights

- New construction office building available now
- 19,819 SF divisible to 1,776 SF
- Central Pooler location
- Less than a 5 minute drive from major restaurants and retailers
- 3/1,000 SF parking ratio
- Units delivered in white box condition Tenant build out negotiable

Lease Rate

Contact listing agent.

Availability

UNIT	SIZE (SF)
101	LEASED
102	1,784
103	1,783
104	1,836
105	1,835
106	1,783
107	1,784
108	1,835
109	1,836
110	1,784
111	1,783
112	1,776
TOTAL	19,819 SF

Site Plan



The Shops
@ POOLER PARKWAY

PAPAYA
Thai

SLAPFISH

Floor Plan

±1,776 - 19,819 SF
(Units can be combined)

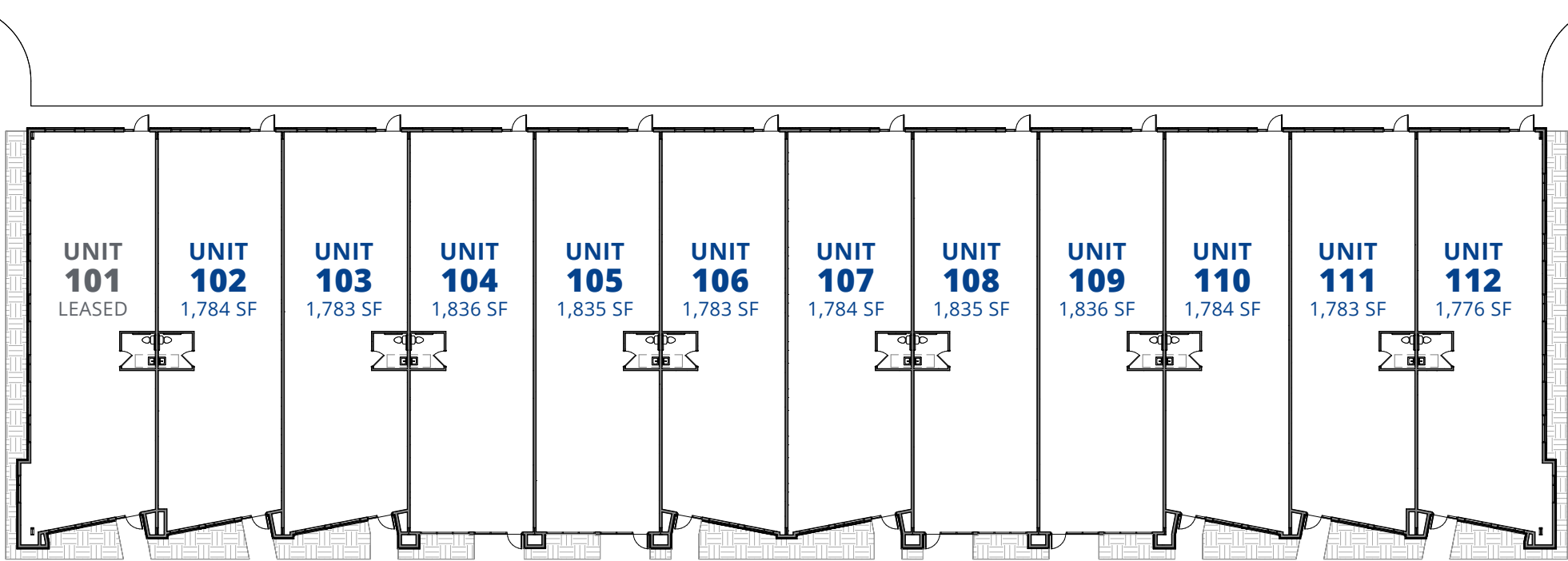

Surrounding Area



Distances

Interstate-95	1.8 Miles
Savannah Airport	3.5 Miles
Interstate-16	3.6 Miles
Downtown Savannah	16 Miles



For Lease

Durham Business Park

Durham Park Boulevard
Pooler, Georgia

Sebastian Findlay, SIOR

Principal
+1 912 483 6160
sebastian.findlay@colliers.com



Colliers | Savannah
545 E York Street
Savannah, GA 31401
Main: +1 912 233 7111
colliers.com/savannah



This document has been prepared by Colliers International for advertising and general information only. Colliers International makes no guarantees, representations or warranties of any kind, expressed or implied, regarding the information including, but not limited to, warranties of content, accuracy and reliability. Any interested party should undertake their own inquiries as to the accuracy of the information. Colliers International excludes unequivocally all inferred or implied terms, conditions and warranties arising out of this document and excludes all liability for loss and damages arising there from. This publication is the copyrighted property of Colliers International and/or its licensor(s).

©2024. All rights reserved.