

Development Land FOR SALE

**2007 S US HWY 59
Shenandoah, IA 51601**

Property Highlights

- \$795,000
- 3.75 AC / 163,350 SF
- 6 Unit Motel – 4,112 SF
- Concrete Parking– 13,350 SF
- Excellent Highway Visibility
- Highway Signage
- Lighted Intersection
- Cross Roads of HWY 59 & Airport Road/Nishna Road

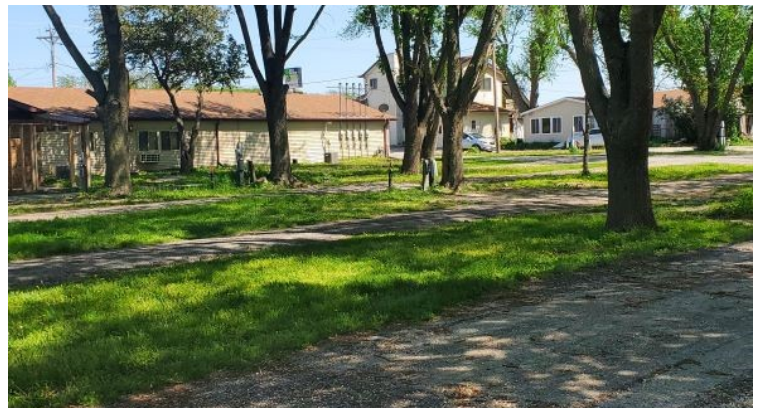

Offering Summary

Available SF:	4,112 SF
Sale Price	\$795,000
Year Built	1940
Year Renovated	1980
Lot Size	3.75
Zoning	C– Commercial
Traffic Count	2,684

Listed By:

Mike Blackmon

Cell: (402) 981-7337

Mike.Blackmon@bhhsambcommercial.com

This information has been secured from the property owner or sources we believe to be reliable, but we make no representations or warranties, expressed or implied, as to the accuracy or completeness of the confidential information. Returns are not guaranteed and cash flow may be interrupted in part or in whole due to market, economic, environmental or other conditions. References to square footage or age are approximate. Measurements for any property plans are approximate and not to scale. Some graphics might be representations. Buyer must verify the information prior to purchase or lease and bears all risk for any inaccuracies. All marks displayed on this document are the property of their respective owners. Photos herein are the property of their respective owners and use of these images without the express written consent of the owner is prohibited. ©2019 BHH Affiliates, LLC. An independently owned and operated franchise of BHH Affiliates, LLC. Berkshire Hathaway HomeServices and the Berkshire Hathaway HomeServices symbol are registered service marks of HomeServices of America, Inc. © Equal Housing Opportunity.

PROPERTY DETAILS

For Sale: \$795,000

2007 S US HWY 59

Shenandoah, IA 51601

Property Details

Property Type	Land
Zoning	C- Commercial
Lot Size	3.75 AC
Traffic Count	2,684
Cross Streets	Fremont St & US 59
Property Taxes	\$2,222.00

Parking & Transportation

Parking Type	Surface
Parking Spaces	15

Utilities & Amenities

Central HVAC	Yes
Restrooms	8 / 2 Sink Kitchens

Location Information

Building Name	59er Motel & Campground
Street Address	2007 S US HWY 59
City, State, Zip	Shenandoah, IA 51601
County/Township	Fremont

Building Information

Building Size	4,112 SF
Building Class	C
Number of Floors	1
Year Built	1940
Year Renovated	1980

Camp Ground

25 Spaces
City Sewer
Electric to Each Space
Cable Available From Media Comm
Zoning and Code Jurisdiction: Fremont Country Iowa
No License Required

Demographics

Proximity:	1 Mile	3 Miles	5 Miles
Total Population:	2,454	5,057	5,356
Households	1,106	2,258	2,383
HH Income	\$60,973	\$62,317	\$63,260

Listed By:

Mike Blackmon

Cell: (402) 981-7337

Mike.Blackmon@bhhsambcommercial.com

This information has been secured from the property owner or sources we believe to be reliable, but we make no representations or warranties, expressed or implied, as to the accuracy or completeness of the confidential information. Returns are not guaranteed and cash flow may be interrupted in part or in whole due to market, economic, environmental or other conditions. References to square footage or age are approximate. Measurements for any property plans are approximate and not to scale. Some graphics might be representations. Buyer must verify the information prior to purchase or lease and bears all risk for any inaccuracies. All marks displayed on this document are the property of their respective owners. Photos herein are the property of their respective owners and use of these images without the express written consent of the owner is prohibited. ©2019 BHH Affiliates, LLC. An independently owned and operated franchise of BHH Affiliates, LLC. Berkshire Hathaway HomeServices and the Berkshire Hathaway HomeServices symbol are registered service marks of HomeServices of America, Inc. © Equal Housing Opportunity.

Berkshire Hathaway HS | Ambassador Real Estate Commercial Division
331 Village Pointe Plaza
Omaha, NE 68118
402-547-5062

**BERKSHIRE
HATHAWAY** | Ambassador
HomeServices Real Estate

COMMERCIAL DIVISION

BUILDING LAYOUT

For Sale: \$795,000

2007 S US HWY 59

Shenandoah, IA 51601

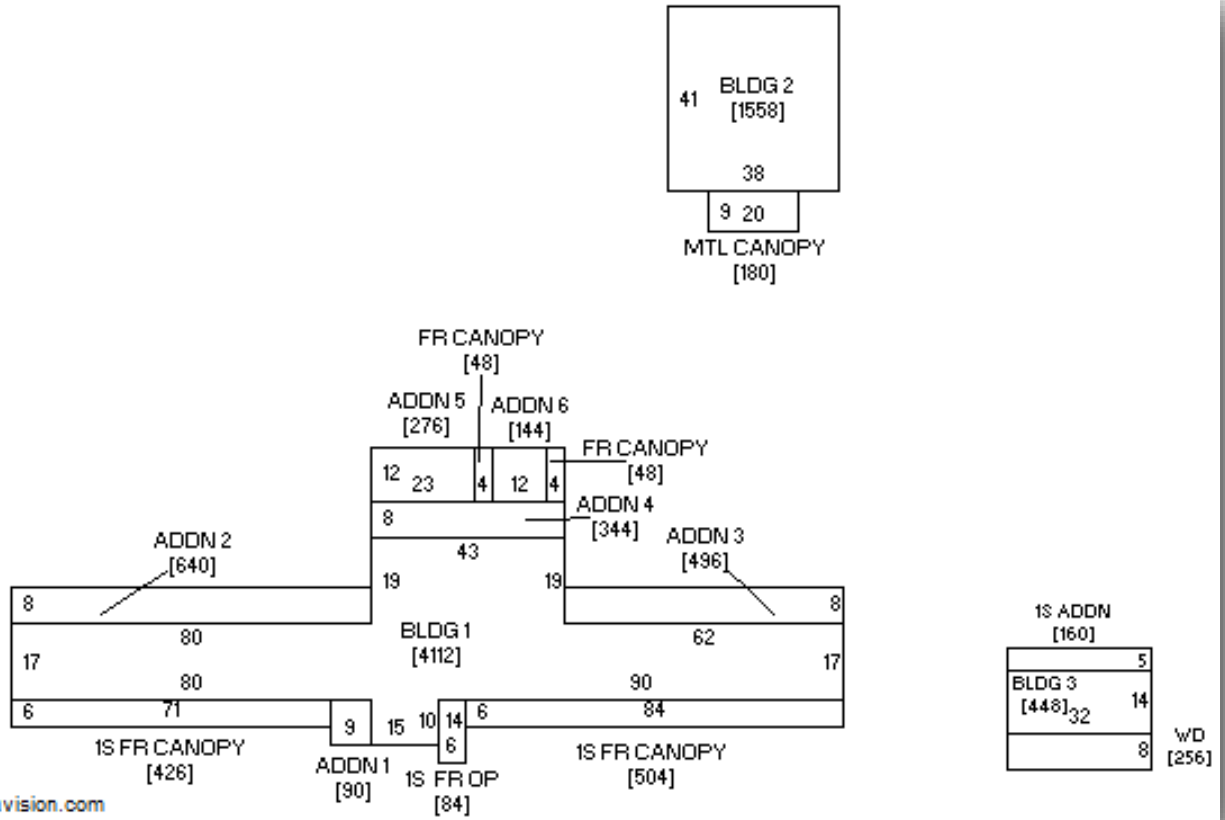

Listed By:

Mike Blackmon

Cell: (402) 981-7337

Mike.Blackmon@bhhsambcommercial.com

This information has been secured from the property owner or sources we believe to be reliable, but we make no representations or warranties, expressed or implied, as to the accuracy or completeness of the confidential information. Returns are not guaranteed and cash flow may be interrupted in part or in whole due to market, economic, environmental or other conditions. References to square footage or age are approximate. Measurements for any property plans are approximate and not to scale. Some graphics might be representations. Buyer must verify the information prior to purchase or lease and bears all risk for any inaccuracies. All marks displayed on this document are the property of their respective owners. Photos herein are the property of their respective owners and use of these images without the express written consent of the owner is prohibited. ©2019 BHH Affiliates, LLC. An independently owned and operated franchise of BHH Affiliates, LLC. Berkshire Hathaway HomeServices and the Berkshire Hathaway HomeServices symbol are registered service marks of HomeServices of America, Inc. © Equal Housing Opportunity.

Berkshire Hathaway HS | Ambassador Real Estate Commercial Division
331 Village Pointe Plaza
Omaha, NE 68118
402-547-5062

**BERKSHIRE
HATHAWAY** | Ambassador
HomeServices Real Estate

COMMERCIAL DIVISION

RETAILER AERIAL

For Sale: \$795,000

2007 S US HWY 59
Shenandoah, IA 51601

Retailers

H&R Block	State Farm Insurance	Orscheln Farm & Home
Chevrolet	U-Haul	Department of Veteran Affairs
Walmart	Floors To Go	SWI World Travel & Tours
O'Reilly Auto Parts	Subway	
McDonald's	Hy-Vee	



Listed By:

Mike Blackmon

Cell: (402) 981-7337

Mike.Blackmon@bhhsambcommercial.com

This information has been secured from the property owner or sources we believe to be reliable, but we make no representations or warranties, expressed or implied, as to the accuracy or completeness of the confidential information. Returns are not guaranteed and cash flow may be interrupted in part or in whole due to market, economic, environmental or other conditions. References to square footage or age are approximate. Measurements for any property plans are approximate and not to scale. Some graphics might be representations. Buyer must verify the information prior to purchase or lease and bears all risk for any inaccuracies. All marks displayed on this document are the property of their respective owners. Photos herein are the property of their respective owners and use of these images without the express written consent of the owner is prohibited. ©2019 BHH Affiliates, LLC. An independently owned and operated franchise of BHH Affiliates, LLC. Berkshire Hathaway HomeServices and the Berkshire Hathaway HomeServices symbol are registered service marks of HomeServices of America, Inc. © Equal Housing Opportunity.

Berkshire Hathaway HS | Ambassador Real Estate Commercial Division
331 Village Pointe Plaza
Omaha, NE 68118
402-547-5062

BERKSHIRE HATHAWAY | Ambassador
HomeServices | Real Estate

COMMERCIAL DIVISION

PLOT AERIAL

For Sale: \$795,000

2007 S US HWY 59
Shenandoah, IA 51601



Listed By:

Mike Blackmon

Cell: (402) 981-7337

Mike.Blackmon@bhhsambcommercial.com

This information has been secured from the property owner or sources we believe to be reliable, but we make no representations or warranties, expressed or implied, as to the accuracy or completeness of the confidential information. Returns are not guaranteed and cash flow may be interrupted in part or in whole due to market, economic, environmental or other conditions. References to square footage or age are approximate. Measurements for any property plans are approximate and not to scale. Some graphics might be representations. Buyer must verify the information prior to purchase or lease and bears all risk for any inaccuracies. All marks displayed on this document are the property of their respective owners. Photos herein are the property of their respective owners and use of these images without the express written consent of the owner is prohibited. ©2019 BHH Affiliates, LLC. An independently owned and operated franchise of BHH Affiliates, LLC. Berkshire Hathaway HomeServices and the Berkshire Hathaway HomeServices symbol are registered service marks of HomeServices of America, Inc. © Equal Housing Opportunity.

Berkshire Hathaway HS | Ambassador Real Estate Commercial Division
331 Village Pointe Plaza
Omaha, NE 68118
402-547-5062

**BERKSHIRE
HATHAWAY** | Ambassador
HomeServices | Real Estate

COMMERCIAL DIVISION

MAP AERIAL

For Sale: \$795,000

2007 S US HWY 59

Shenandoah, IA 51601

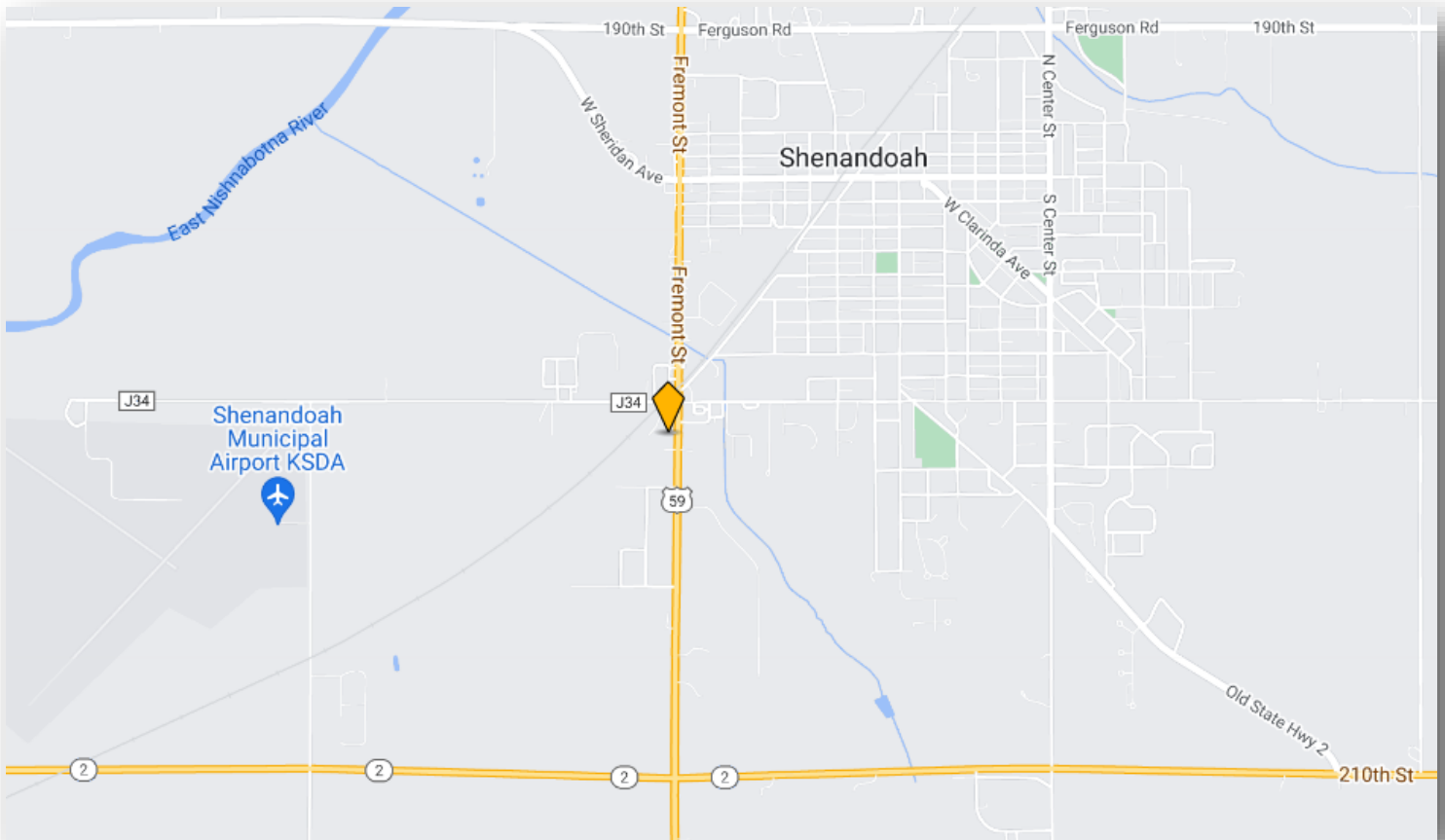

Listed By:

Mike Blackmon

Cell: (402) 981-7337

Mike.Blackmon@bhhsambcommercial.com

This information has been secured from the property owner or sources we believe to be reliable, but we make no representations or warranties, expressed or implied, as to the accuracy or completeness of the confidential information. Returns are not guaranteed and cash flow may be interrupted in part or in whole due to market, economic, environmental or other conditions. References to square footage or age are approximate. Measurements for any property plans are approximate and not to scale. Some graphics might be representations. Buyer must verify the information prior to purchase or lease and bears all risk for any inaccuracies. All marks displayed on this document are the property of their respective owners. Photos herein are the property of their respective owners and use of these images without the express written consent of the owner is prohibited. ©2019 BHH Affiliates, LLC. An independently owned and operated franchise of BHH Affiliates, LLC. Berkshire Hathaway HomeServices and the Berkshire Hathaway HomeServices symbol are registered service marks of HomeServices of America, Inc. © Equal Housing Opportunity.

Berkshire Hathaway HS | Ambassador Real Estate Commercial Division
331 Village Pointe Plaza
Omaha, NE 68118
402-547-5062

**BERKSHIRE
HATHAWAY** | Ambassador
HomeServices | Real Estate

COMMERCIAL DIVISION

PHOTOS

For Sale: \$795,000

2007 S US HWY 59
Shenandoah, IA 51601



Listed By:

Mike Blackmon

Cell: (402) 981-7337

Mike.Blackmon@bhhsambcommercial.com

This information has been secured from the property owner or sources we believe to be reliable, but we make no representations or warranties, expressed or implied, as to the accuracy or completeness of the confidential information. Returns are not guaranteed and cash flow may be interrupted in part or in whole due to market, economic, environmental or other conditions. References to square footage or age are approximate. Measurements for any property plans are approximate and not to scale. Some graphics might be representations. Buyer must verify the information prior to purchase or lease and bears all risk for any inaccuracies. All marks displayed on this document are the property of their respective owners. Photos herein are the property of their respective owners and use of these images without the express written consent of the owner is prohibited. ©2019 BHH Affiliates, LLC. An independently owned and operated franchise of BHH Affiliates, LLC. Berkshire Hathaway HomeServices and the Berkshire Hathaway HomeServices symbol are registered service marks of HomeServices of America, Inc. © Equal Housing Opportunity.

Berkshire Hathaway HS | Ambassador Real Estate Commercial Division
331 Village Pointe Plaza
Omaha, NE 68118
402-547-5062

**BERKSHIRE
HATHAWAY** | Ambassador
HomeServices Real Estate

COMMERCIAL DIVISION