

PARK PLACE

NOW LEASING

OAKPOINT



4005/4009 Banister Lane
Austin, Texas 78704



BUILDING OVERVIEW

Located a short distance from South Congress and downtown Austin, Park Place creates the ideal location for a central-focused business. With fourth floor views of Downtown Austin and the tree-filled landscaping, this four building campus is an outstanding space for all types of offices.

BUILT IN

1985

RENTABLE SPACE

41,946 sf

FLOORS

4

AVG FLOOR PLATE

13,772 sf

RENOVATED

2022

LOT

2.82 acres

PARKING RATIO

3.25:1,000

UNFINISHED CEILING HEIGHT

12'



FEATURED AMENITIES

Ample surface parking,
great highway access,
tree-filled landscaping,
and prime proximity to
Austin's top amenities.



Tree-filled
landscaping



Easy access to Hwy 71,
Loop 360, MoPac &
IH 35



Monument
signage available



Generous
parking



Prime proximity to
Austin's top amenities



Large conference
center





Top amenities in close proximity.

PARK PLACE

- 1 ZILKER**
 - Target
 - Juiceland
 - Uchi
 - Tesla Supercharging Station
 - Snooze an A.M. Eatery
 - Loro
- 2 BOULDIN CREEK**
 - Starbucks
 - Toss Pizzeria & Pub
 - Summer Moon Coffee
 - Mattie's
 - Whataburger
 - Phoebe's Diner - Oltorf
- 3 SOUTH CONGRESS**
 - Magnolia Cafe
 - Torchy's Tacos
 - H-E-B
 - Home Slice Pizza
 - Aba Austin
 - Whip In
- 4 SAINT ELMO**
 - Cathedral of Junk
 - Casa Maria
 - CVS
 - St. Elmo Brewing Company
 - The Git Out - Bar + Kitchen
 - La Flor
- 5 EAST RIVERSIDE**
 - Whataburger
 - P. Terry's Burger Stand
 - Café Crème
 - Jack in the Box
 - Planet Fitness
 - McDonald's
- 6 MCKINNEY**
 - Little Caesars Pizza
 - Bakery Cloud Nine
 - CJ's Tacos
 - Pinthouse Brewing
 - Side Eye Pie
 - Austintatious Cheesecakes





AVAILABILITY

4005 Banister Ln, Suite 100B

SIZE

4,730 sf

AVAILABILITY DATE

11/16/26

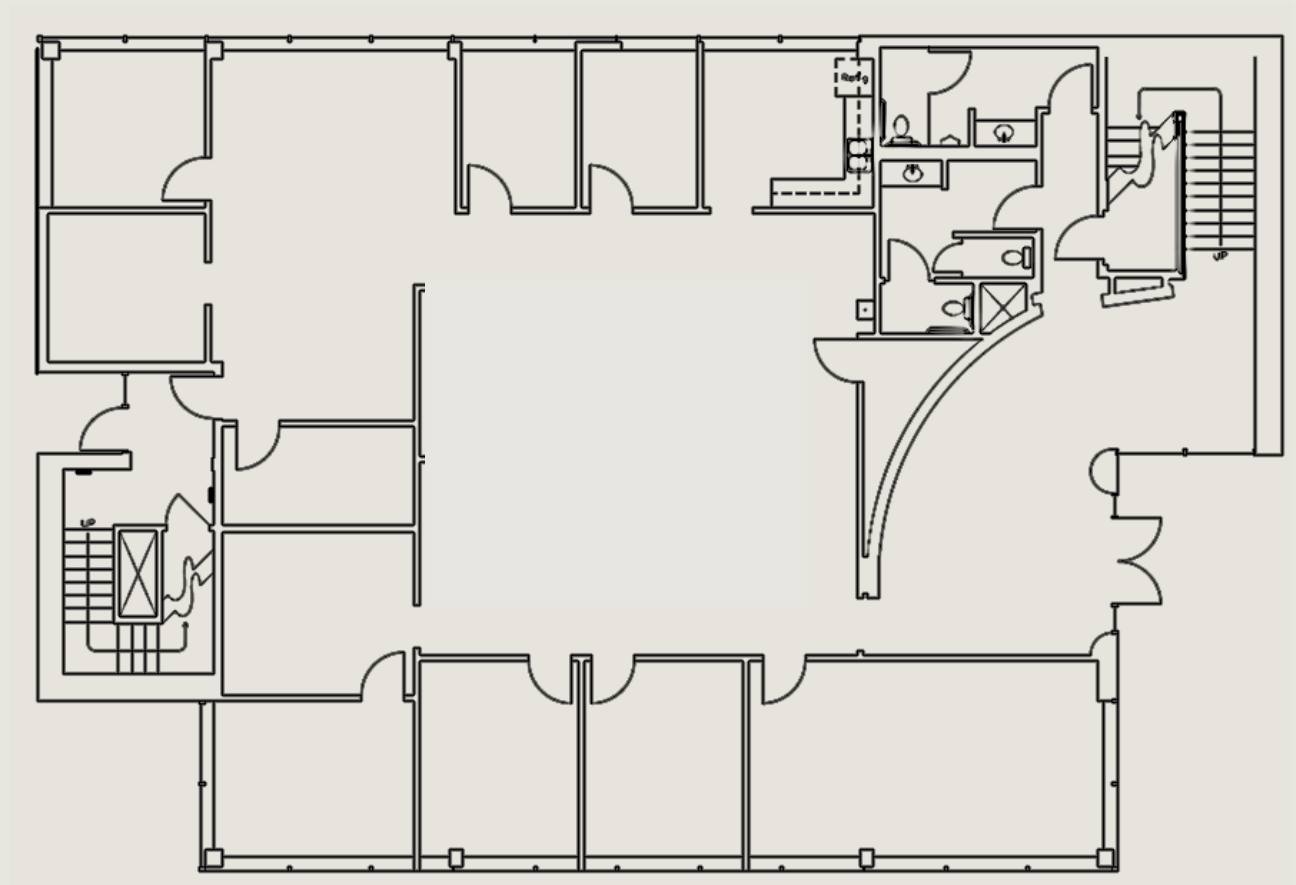



AVAILABILITY

4009 Banister Ln, Suite 102

SIZE

700 sf

AVAILABILITY DATE

8/1/2026

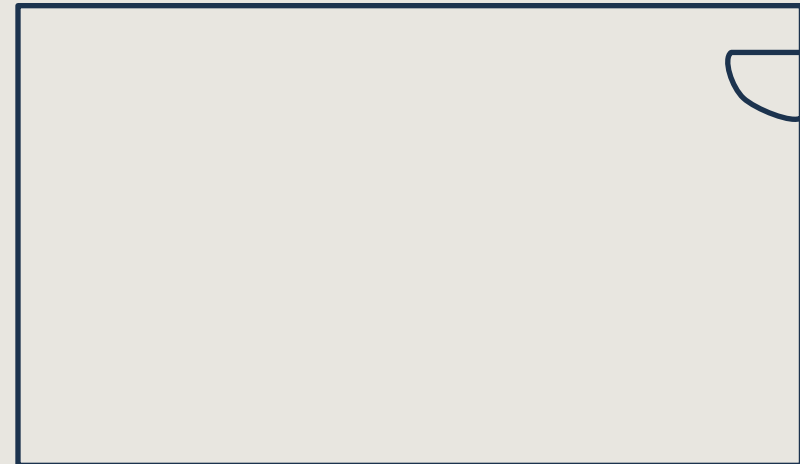

LEVEL 4

LEVEL 3

LEVEL 2

▶ LEVEL 1

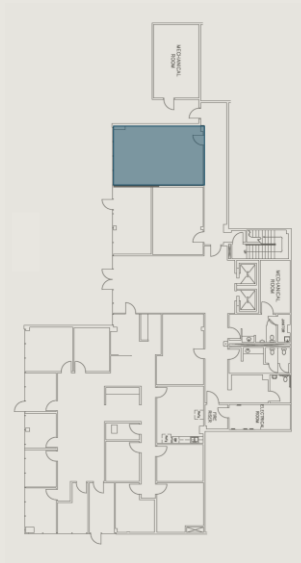



AVAILABILITY

4009 Banister Ln, Suite 250

SIZE

1,170 sf

AVAILABILITY DATE

Available Now

- LEVEL 4
- LEVEL 3
- ▶ LEVEL 2
- LEVEL 1

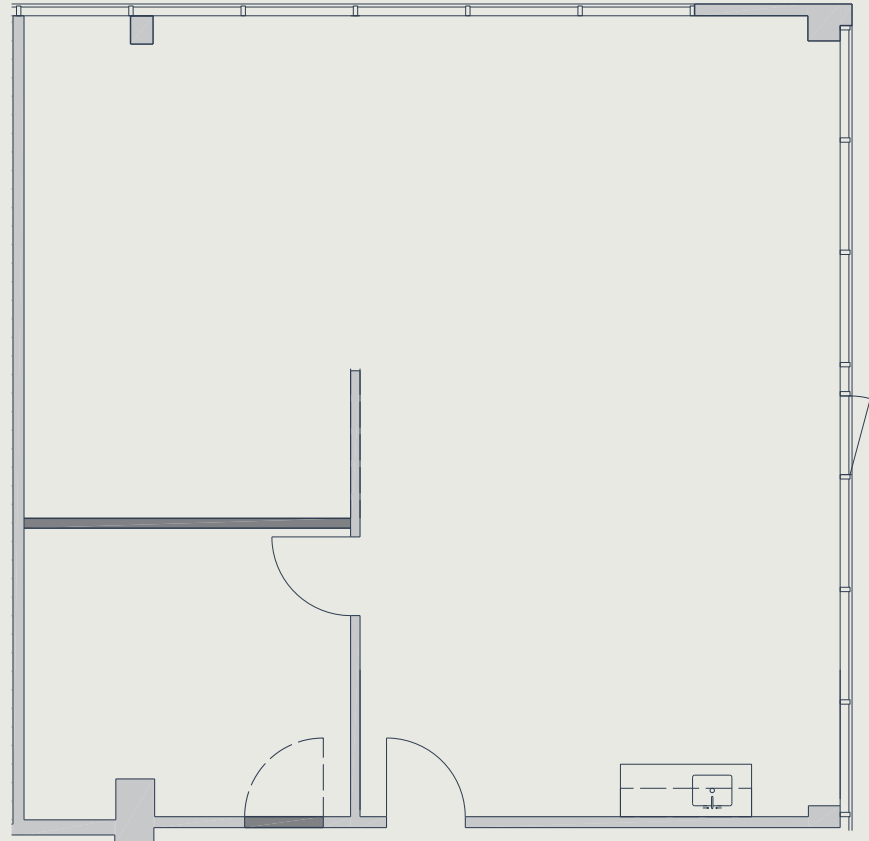
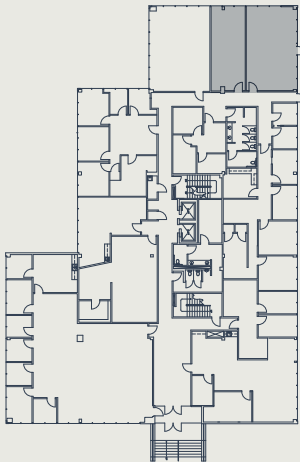



AVAILABILITY

4009 Banister Ln, Suite 280

SIZE

1,344 sf

AVAILABILITY DATE

8/1/2026

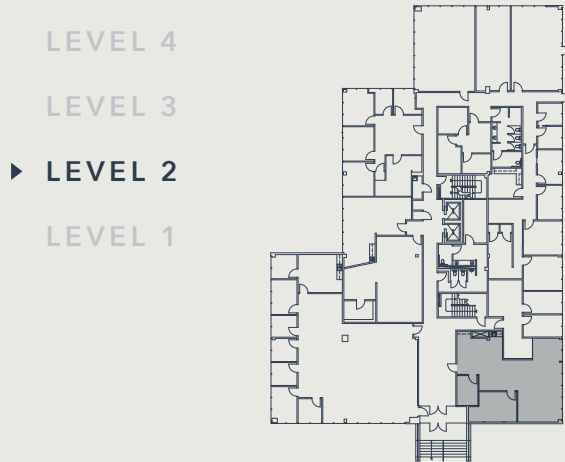
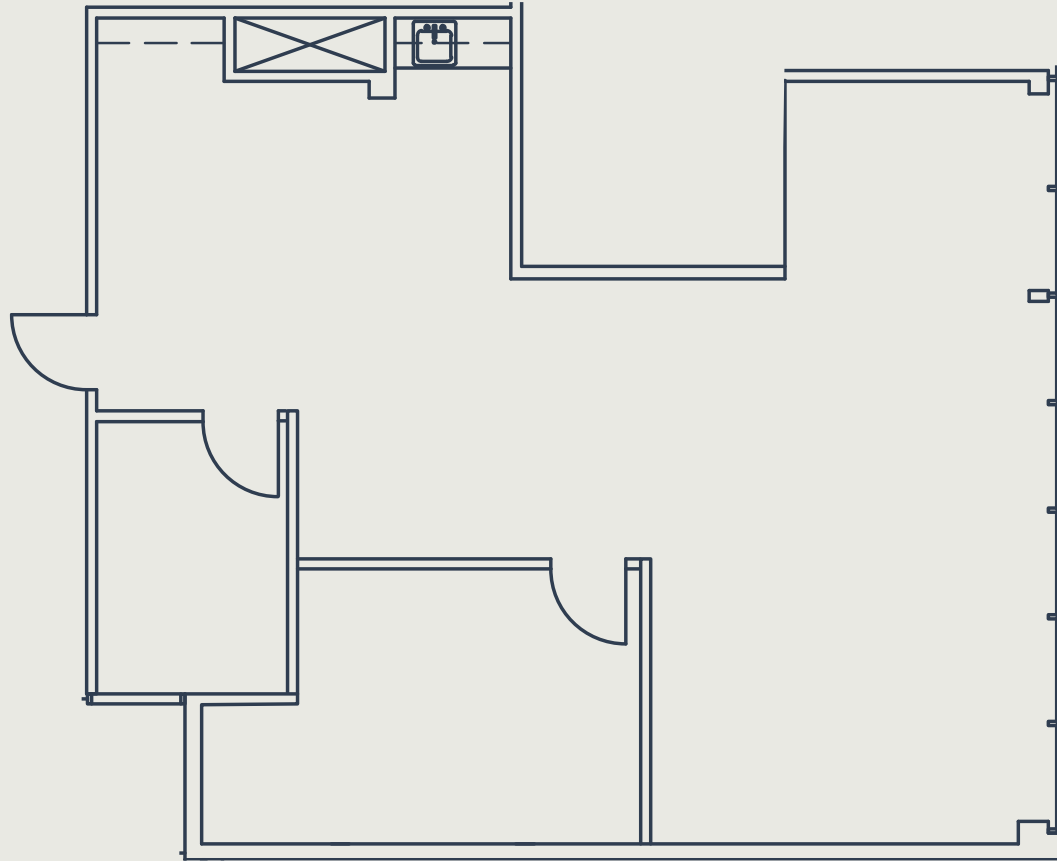



AVAILABILITY

4009 Banister Ln, Suite 300

SIZE

4,343 sf

AVAILABILITY DATE

Available Now

LEVEL 4

▶ LEVEL 3

LEVEL 2

LEVEL 1

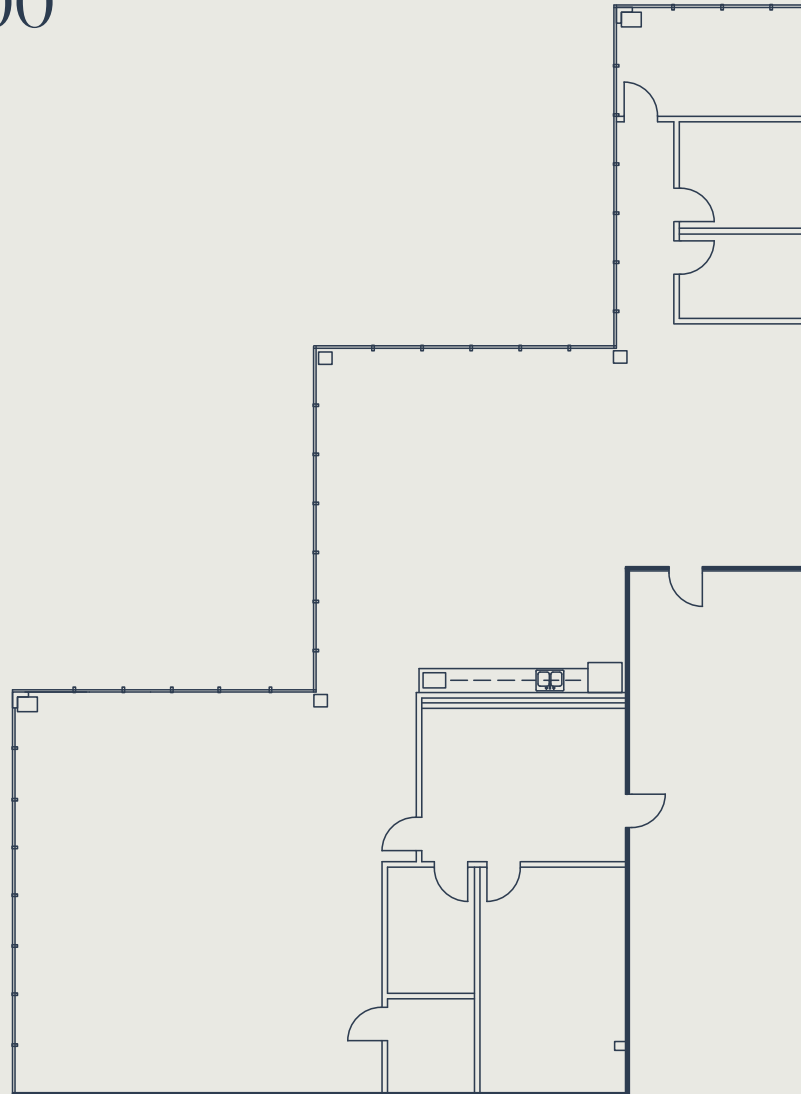
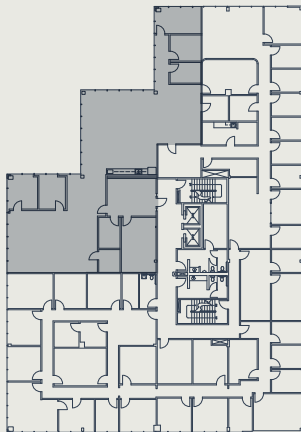



AVAILABILITY

4009 Banister Ln, Suite 400

SIZE

5,247 sf

AVAILABILITY DATE

Available Now

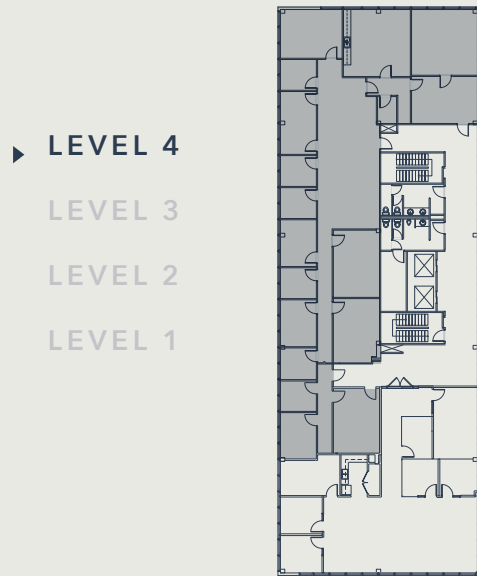
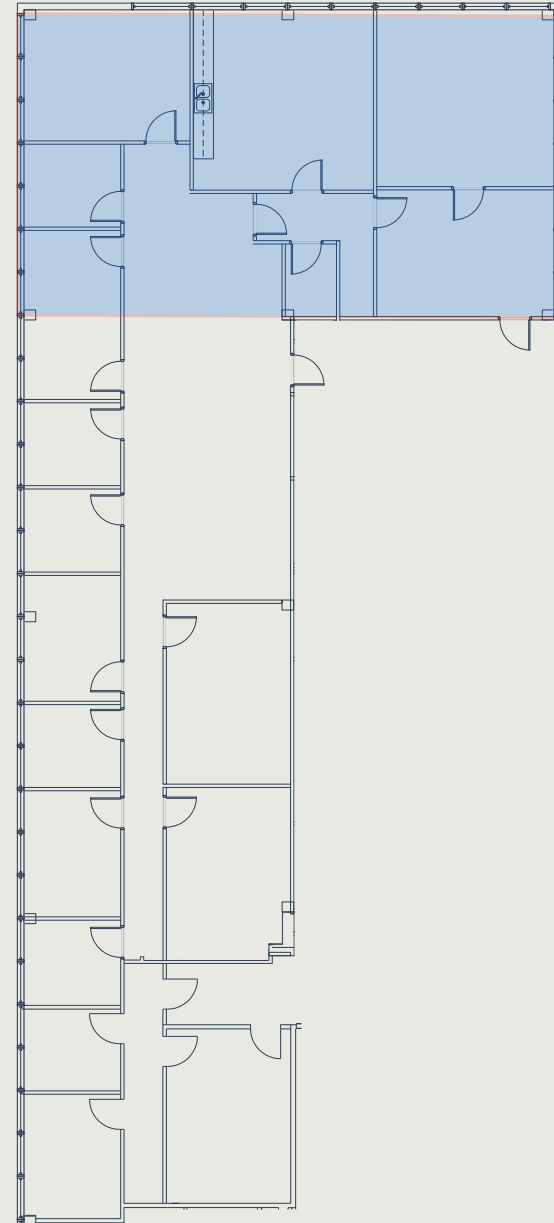



LEASING INFORMATION

Park Place is locally owned and operated by OakPoint, a vertically integrated firm with a diverse portfolio in commercial, multifamily, office, residential, and industrial real estate.

For leasing information, please contact:

RYAN BUSCHA

Director

O (512) 975-2253

E rbuscha@oakpointre.com

DAN FRICKS

Leasing

O (512) 640-6278

E dfricks@oakpointre.com

