



FOR LEASE

Small Office Space Available
1080 Laskin Road
Virginia Beach, VA



Ricky Anderson

Executive Vice President
+1 757 217 1892
ricky.anderson@colliers.com

150 West Main Street
Suite 1100
Norfolk, VA 23510
P: +1 757 490 3300

Features

- ± 6,000 SF two-story office building
- Available Space:
 - Suite 102: ± 650 SF available
 - Suite 103: ± 650 SF available
- Monument signage available
- Close to Birdneck Road/Laskin Road intersection with easy access to I-264
- Close proximity to Sentara Virginia Beach General Hospital, Hilltop Shopping Center, and the Virginia Beach Oceanfront
- Lease Rate: \$1,400 per month (net of electric and janitorial)

Floor Plan

Suite 103
± 650 SF available

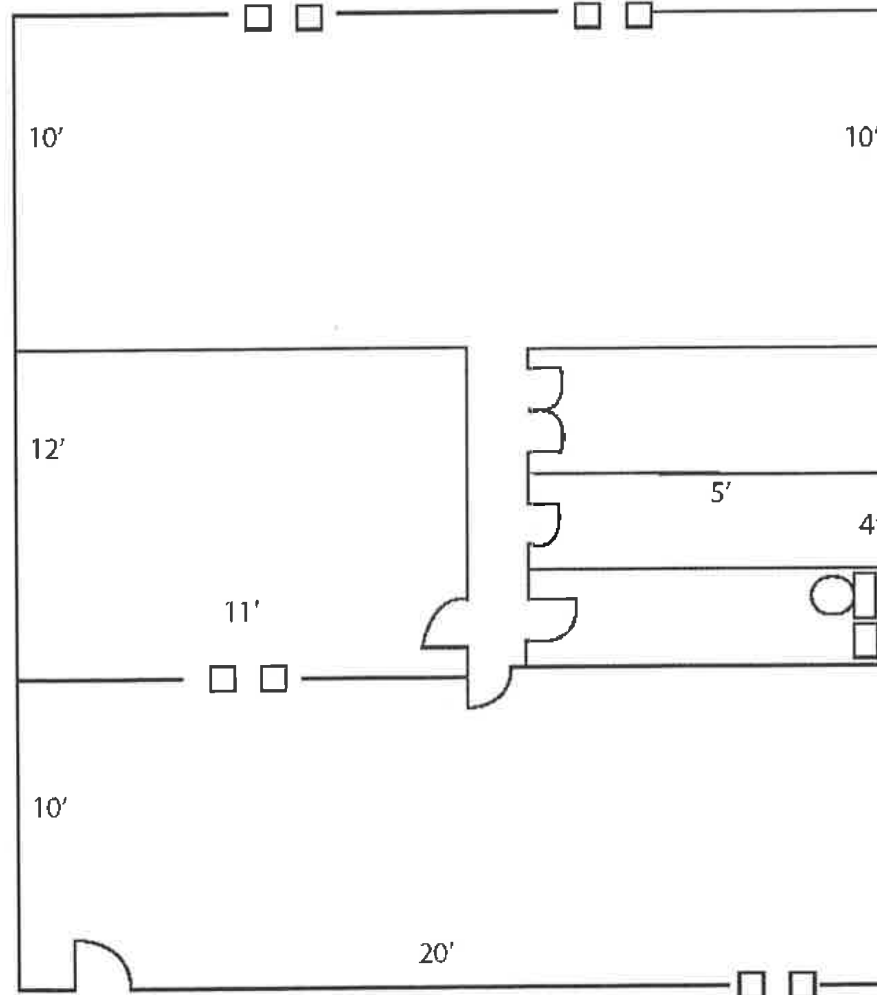

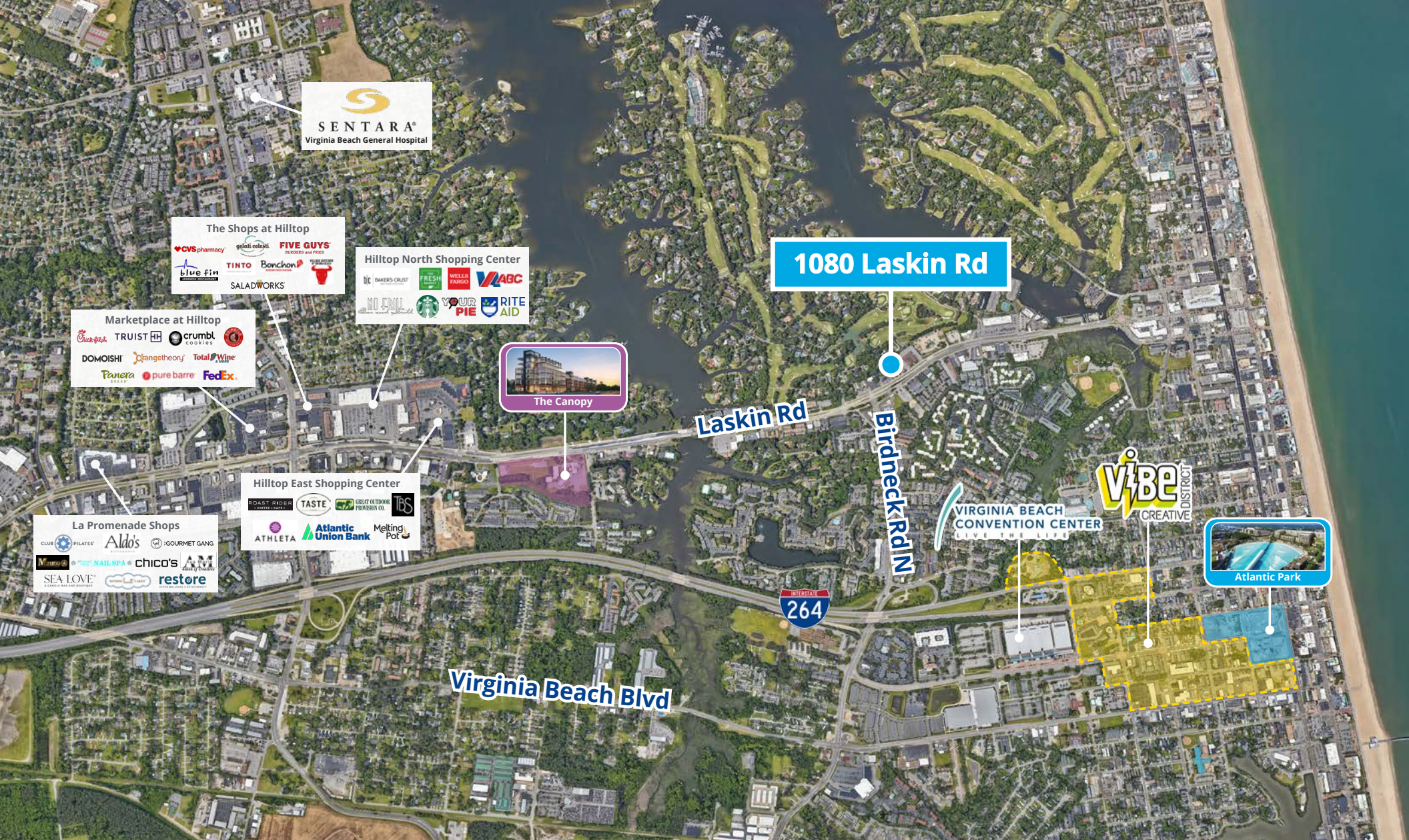

1080 Laskin Rd



Ricky Anderson

Executive Vice President
 +1 757 217 1892
ricky.anderson@colliers.com

150 West Main Street
 Suite 1100
 Norfolk, VA 23510
 P: +1 757 490 3300

