

2600 TELEGRAPH ROAD

BLOOMFIELD HILLS



PREMISES

- Two-story, 90,000 SF office building

AVAILABILITY

- 2nd Floor: 40,513 SF
- 1st Floor: Suites from 591 SF up to 6,816 SF (contiguous)
- Lower Level: Storage and data room

RENTAL RATE

- Floor 1 & 2: \$23.50 psf
- Lower Level: \$19.95 psf
- 2026 Base Year, plus electricity

FEATURES AND AMENITIES

- Building and Monument Signage Available
- Expansive two-story atrium lobby with three-level spiral staircase
- Premium detailing including marble floor, polished oak and solid brass
- Theater-style auditorium
- Magnificent wooded setting
- Ample well-lit parking including underground executive parking
- Computerized security/entry access
- Nearby fine dining, hotels and retail
- Convenient I-75 access via Square Lake Road interchange

FOR MORE INFORMATION

Daniel Canvasser
Wade Lorimer
John Eagal
Newmark | nmrk.com
248.350.9500

Dan Leppink dleppink@kojaian.com
Eric Horwitz ehorwitz@kojaian.com
Kojaian Management Corporation
Kojaian.com
248.644.7600

NEWMARK

MORE THAN
BUILDINGS

LOCATION | BUSINESS | IMAGE | SUCCESS

KOJAIANO
KOJAIAN.COM

2600 TELEGRAPH ROAD

BLOOMFIELD HILLS

1ST FLOOR

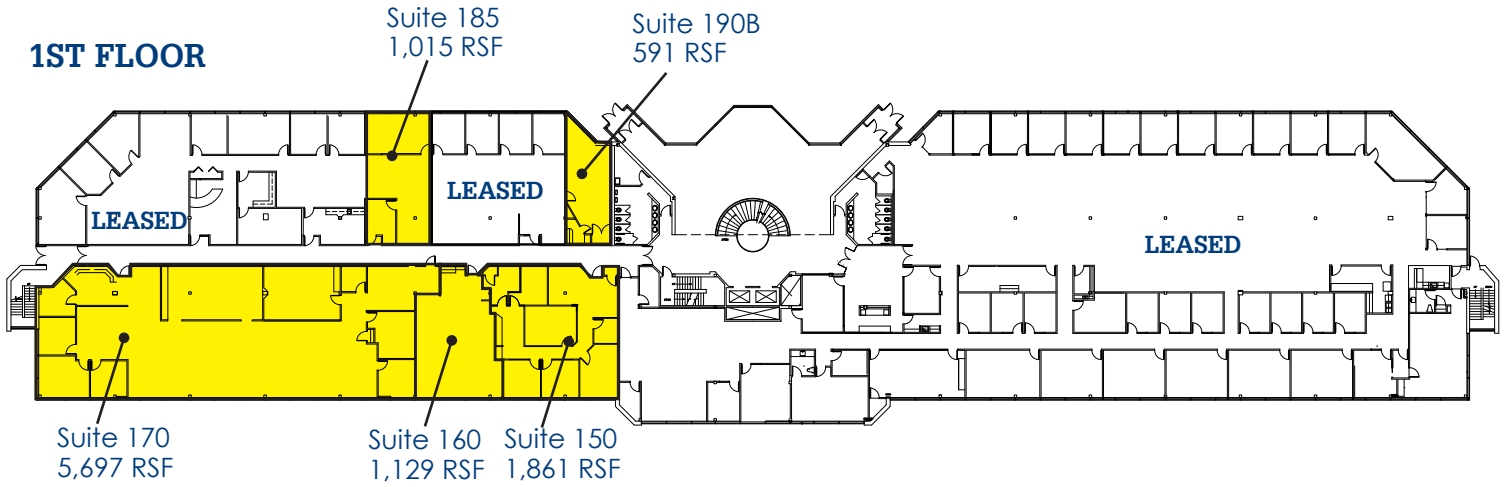

2ND FLOOR

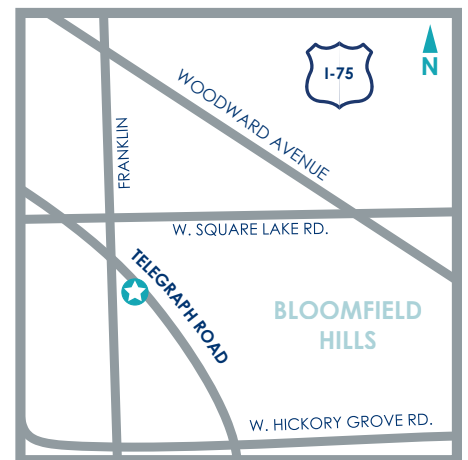
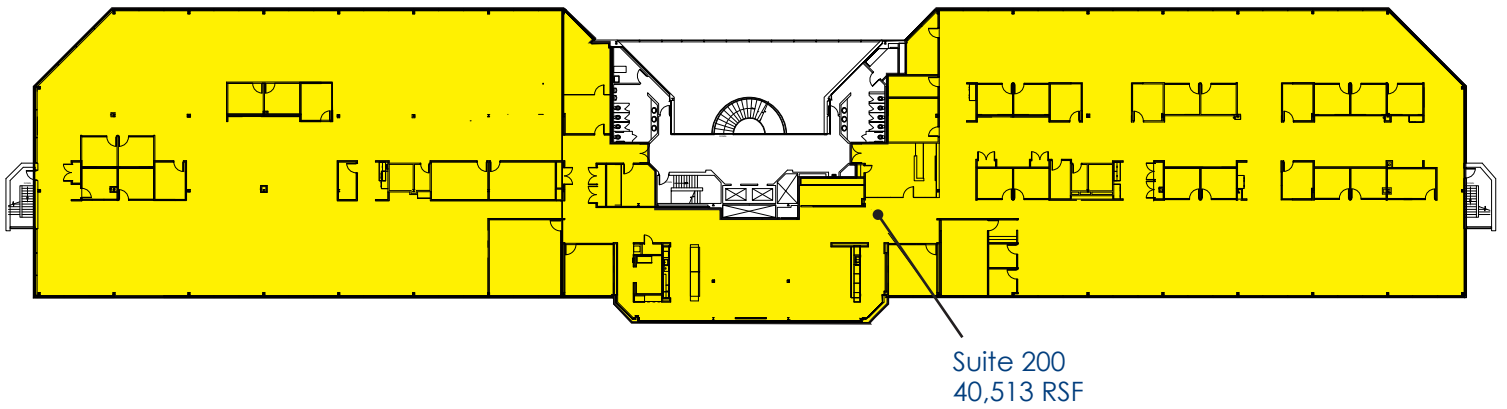

FOR MORE INFORMATION

Daniel Canvasser
Wade Lorimer
John Eagal
Newmark | nmrk.com
248.350.9500

Dan Leppink dleppink@kojaian.com
Eric Horwitz ehorwitz@kojaian.com
Kojaian Management Corporation
Kojaian.com
248.644.7600

NEWMARK

KOJAIAN
KOJAIAN.COM