



FAR NE HEIGHTS MULTI USE OFFICE

EUBANK BLVD NE, NORTH OF SPAIN RD NE
5528 EUBANK BOULEVARD NORTHEAST, ALBUQUERQUE, NM 87111



FOR LEASE

AVAILABLE SPACE
1,200 - 5,000 SF

RATE
\$13.00 - \$18.00 PSF
Modified Gross

Jeremy Salazar
jsalazar@resolutre.com
505.337.0777

PROPERTY HIGHLIGHTS

- Excellent Visibility in desirable Far Northeast Heights
- Highly adaptable building; suitable to many uses
- Open floor plan suites
- Multiple options and configurations available depending on tenant's needs
- Tenant improvements available
- Large meeting space great for a church or conferences
- Monument signage available
- Modified Gross Lease: base rent plus utilities

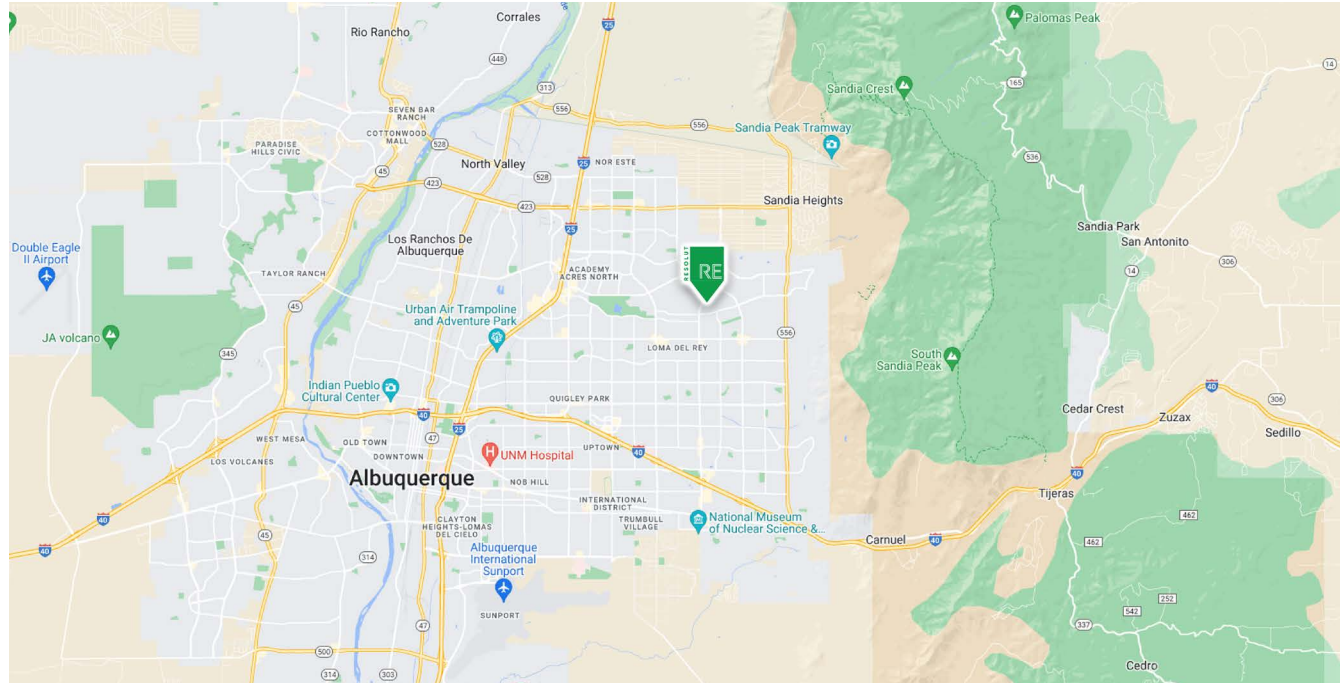

AREA TRAFFIC GENERATORS



Jeremy Salazar
jsalazar@resolutre.com | 505.337.077

DEMOGRAPHIC SNAPSHOT 2023

 **121,246**
POPULATION
3-MILE RADIUS

 **\$125,334.00**
AVG HH INCOME
3-MILE RADIUS

 **81,250**
DAYTIME POPULATION
3-MILE RADIUS

 **TRAFFIC COUNTS**
Eubank Blvd NE: 26,109 VPD
(Sites USA 2023)

PROPERTY OVERVIEW

This unique property is highly adaptable to many uses from educational, small fitness users, conference center, and traditional office users. Each room within Suite 5 has an open floor plan which can be customized to fit a tenant's needs. Suite 5 has the option of four different configurations ranging from 1,200 SF to 3,700 SF and can include a large common area conference space.

Suite 2 includes the common area conference space and a private classroom style room. This space is great for a weekend church or educational facility. The large conference area and common area restrooms are only available on evenings and weekends.

Suite 2 and Suite 5 can include monument signage on the highly trafficked Eubank Blvd NE.

LOCATION OVERVIEW

5528 Eubank Blvd NE is a highly visible property situated between Spain Rd NE and Juan Tabo Blvd NE. Co-tenants include Balanced Physical Therapy, Ambrose Barber and Styling, Tutor Me K-12 tutoring services, Pegasus Massage, A Tax Solutions, Mayberry Senior Services, and New Mexico Early Learning Academy.

PROPERTY OVERVIEW

SF:	1,200 - 5,000 SF
Zoning:	MX-T
Submarket:	Far Northeast Heights



FAR NE HEIGHTS MULTI USE OFFICE | 5528 Eubank Blvd NE, Albuquerque, NM 87111

SUITE 2

- One dedicated room around 600 SF
- Large, Shared Conference Area 2,000 SF (Only available on evenings and weekends)
- Playground (Only available on evenings and weekends)
- \$1,750/Month

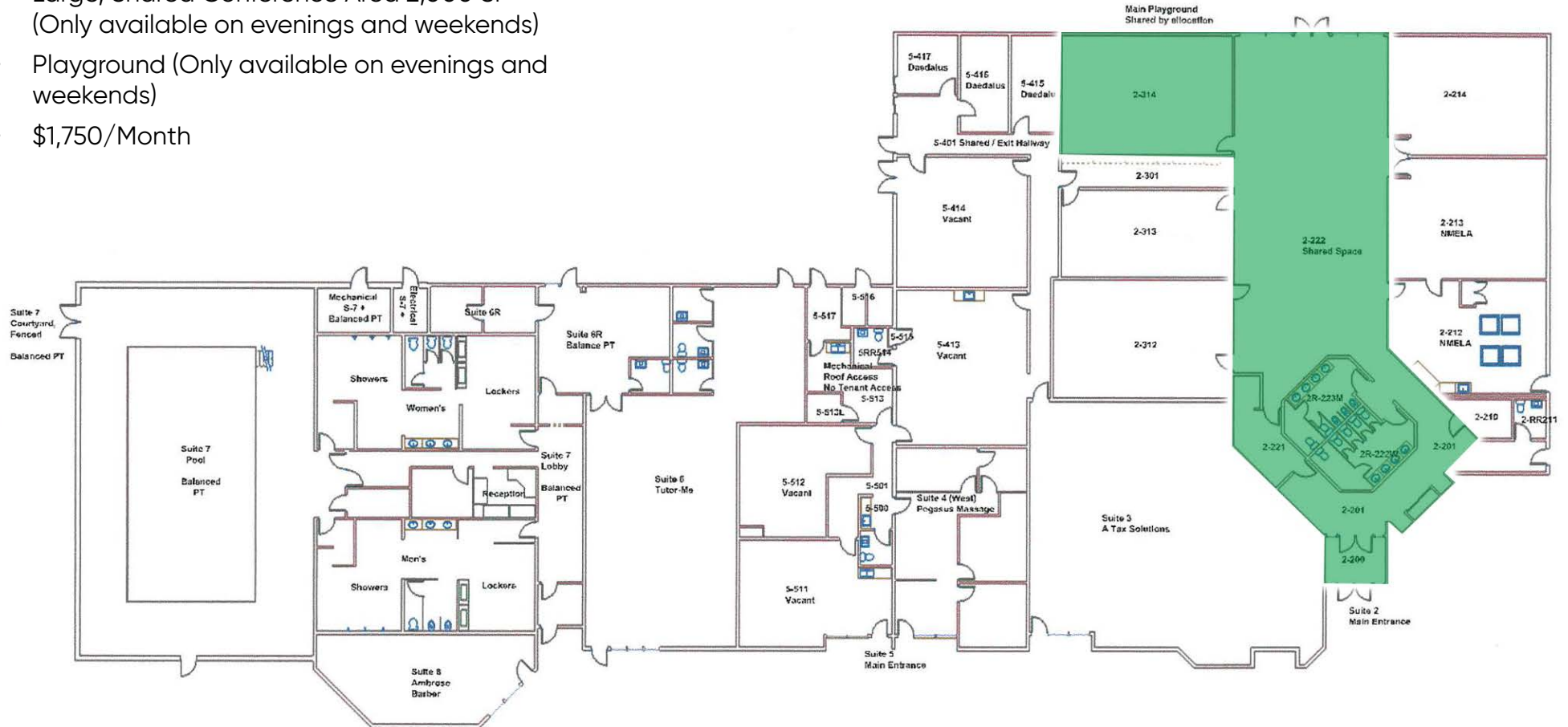

SUITE 2



SUITE 5 OPTION 1

- Five large rooms with great frontage and visibility
- Approximately 3,692 SF
- Starting at \$4,219 month modified gross plus utilities
- Option to Include:
 - Kitchen break area (additional \$525/Month)
 - 2,000 SF shared, Conference Area (weekend use) (additional \$1,100/Month)

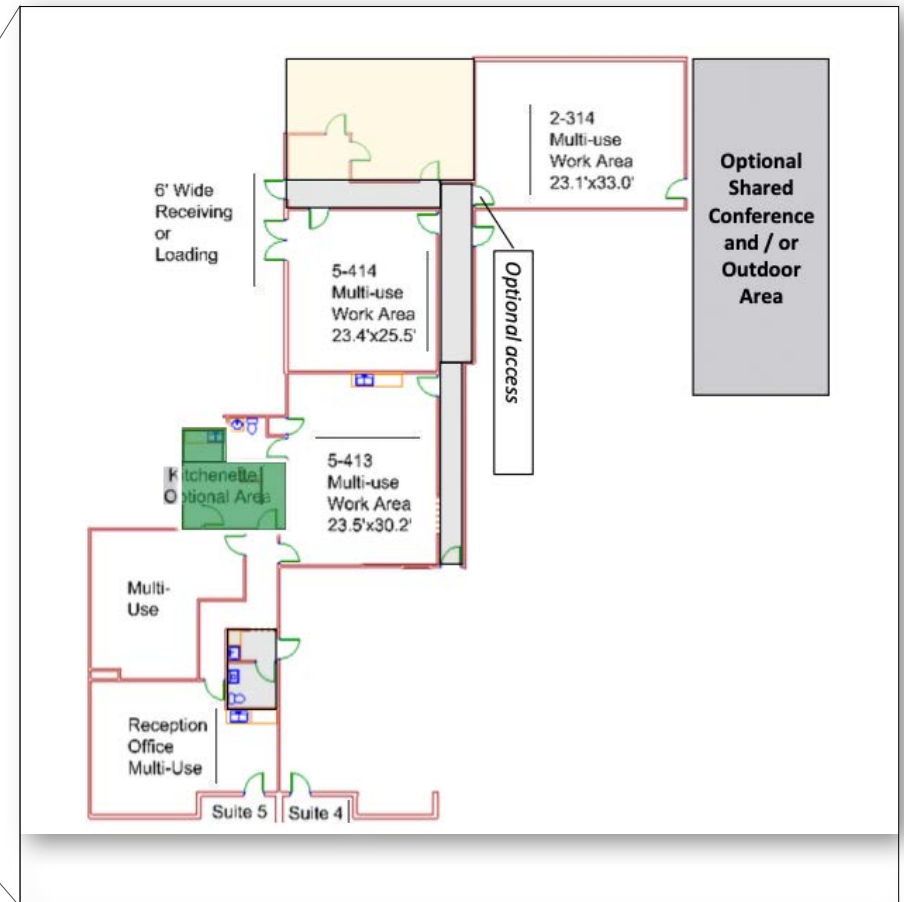
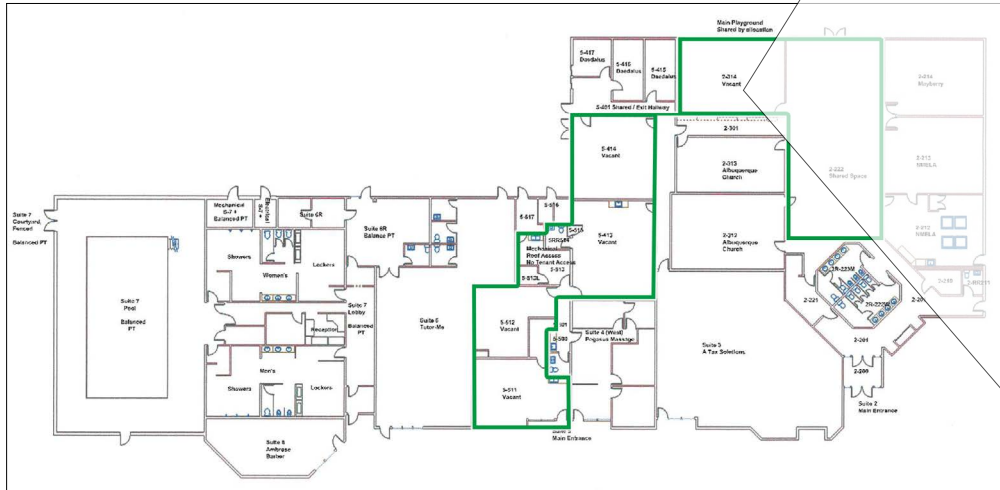

SUITE 5 OPTION 2

- Four large rooms with great frontage and visibility
- Approximately 2,698 SF
- Starting at \$3,369 month modified gross plus utilities
- Option to add:
 - Kitchen break area (additional \$525/Month)

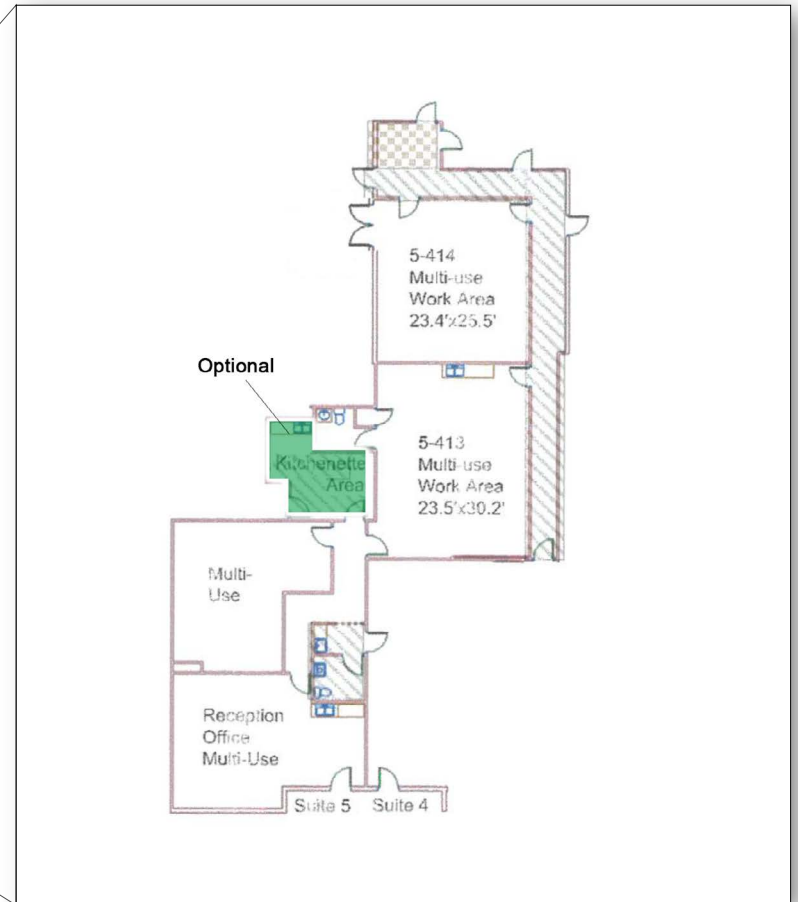
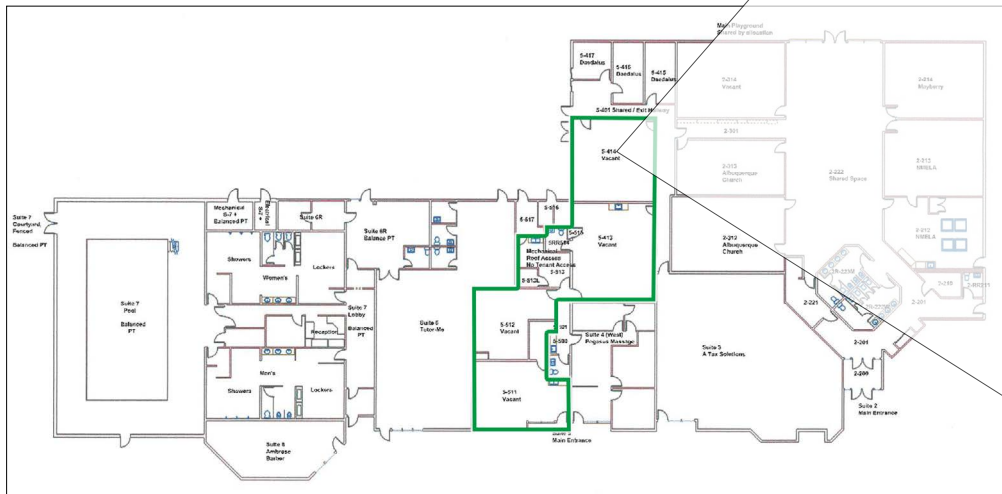

SUITE 5 OPTION 3

- Three large rooms with great frontage and visibility
- Approximately ~2,072 SF
- Starting at \$2,599 month modified gross plus estimated utilities
- Option to Include:
 - Kitchenette (additional \$525/month)

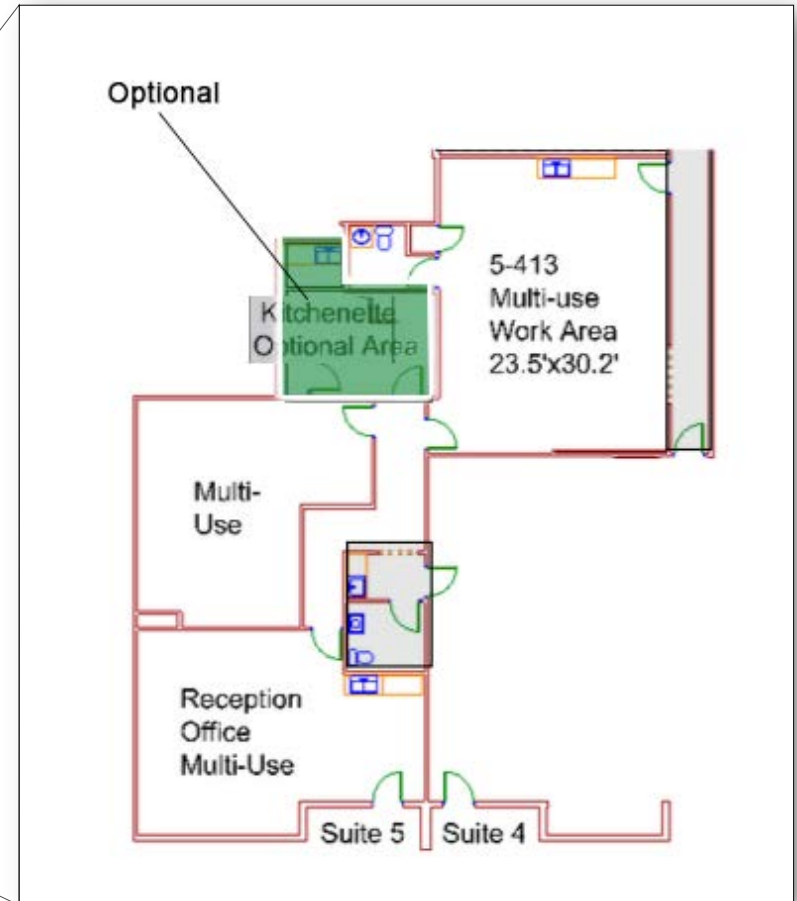
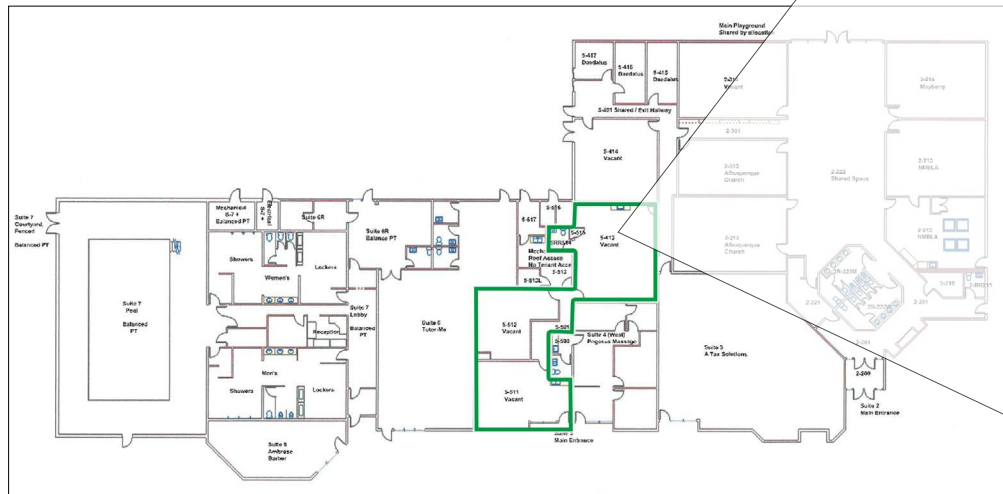

SUITE 5 OPTION 4

- Two large rooms with great frontage and visibility
- Approximately ~1,268 SF
- Starting at \$1,629 month modified gross plus estimated utilities
- Option to Include:
 - Kitchenette (additional \$525/month)

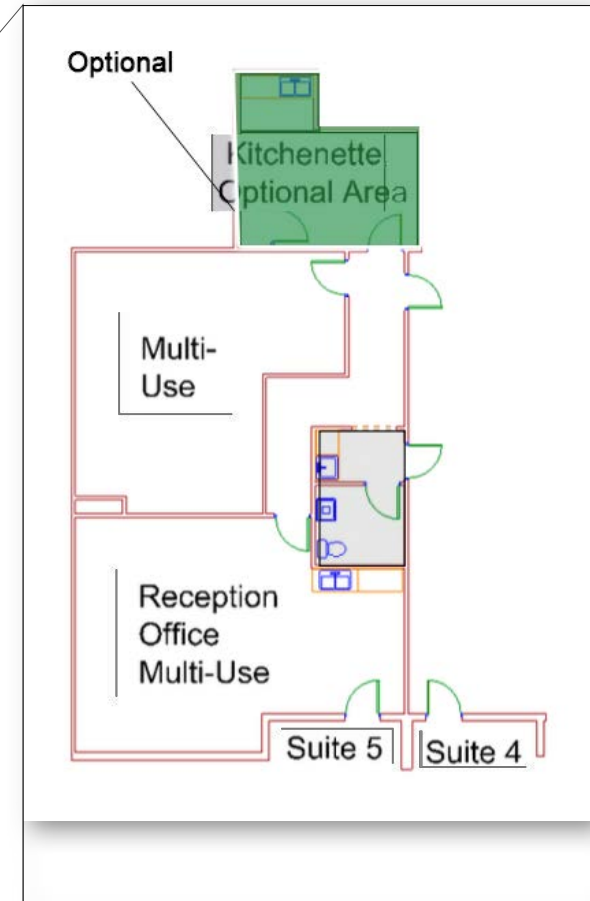
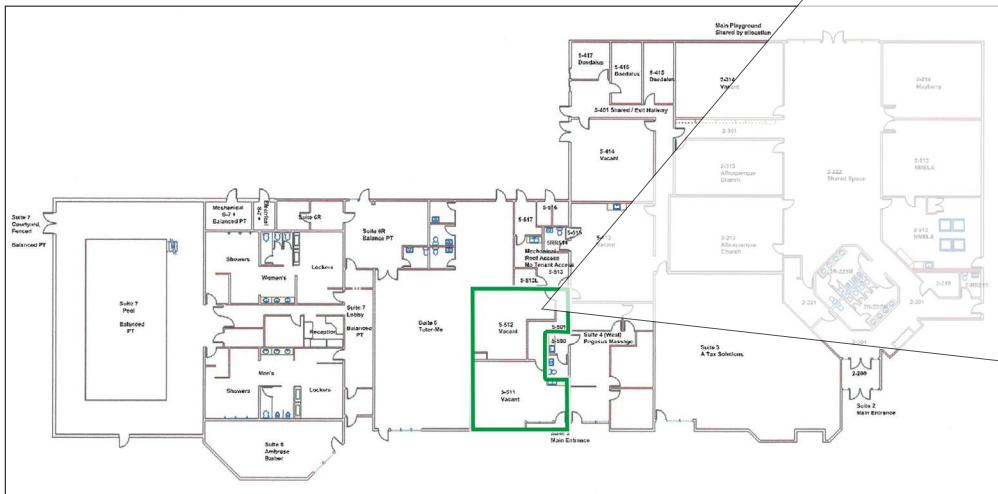

SUITE 5





FAR NE HEIGHTS MULTI USE OFFICE | 5528 Eubank Blvd NE, Albuquerque, NM 87111

