

PIONEER PARKWAY

FOR LEASE



**3201-3217 E PIONEER PARKWAY
ARLINGTON, TEXAS 76010**



ALEX BRYAN
972.965.2878
alex@richyoungcompany.com

GARRETT GOLDSTEIN
214.364.0674
garrett@richyoungcompany.com

Owned and Managed by:

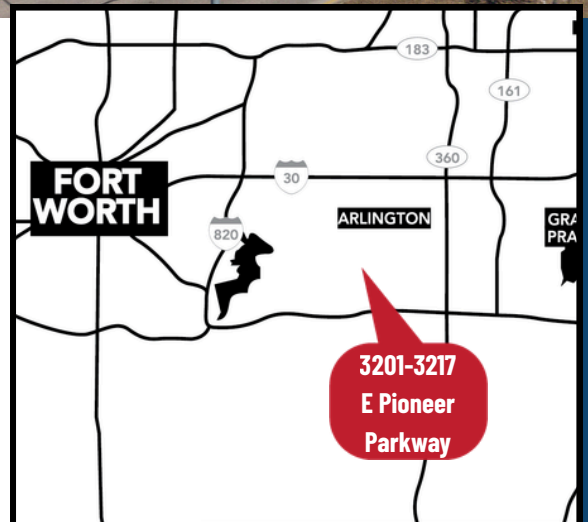

PIONEER PARKWAY

FOR LEASE

Property Details

- Move in ready spaces
- Easy access to Hwy 360 & PGBT
- 100% Air-conditioned
- Paint booth available
- Grade level loading
- Made ready offices

Available Suites:

- Suite 11/12 – 2,000 SF
- Suite 22/23 – 1,400 SF
- Suite 30 – 2,250 SF
- Suite 3217A – 5,802 SF
- Suite 38 – 1,000 SF
- Suite 39 – 1,000 SF
- Suite 44 – 1,600 SF
- Suite 45 – 1,000 SF

ALEX BRYAN

972.965.2878

alex@richyoungcompany.com

GARRETT GOLDSTEIN

214.364.0674

garrett@richyoungcompany.com

Owned and Managed by:



PIONEER PARKWAY

FOR LEASE



Available Space:

#11/12 - 2,000 SF

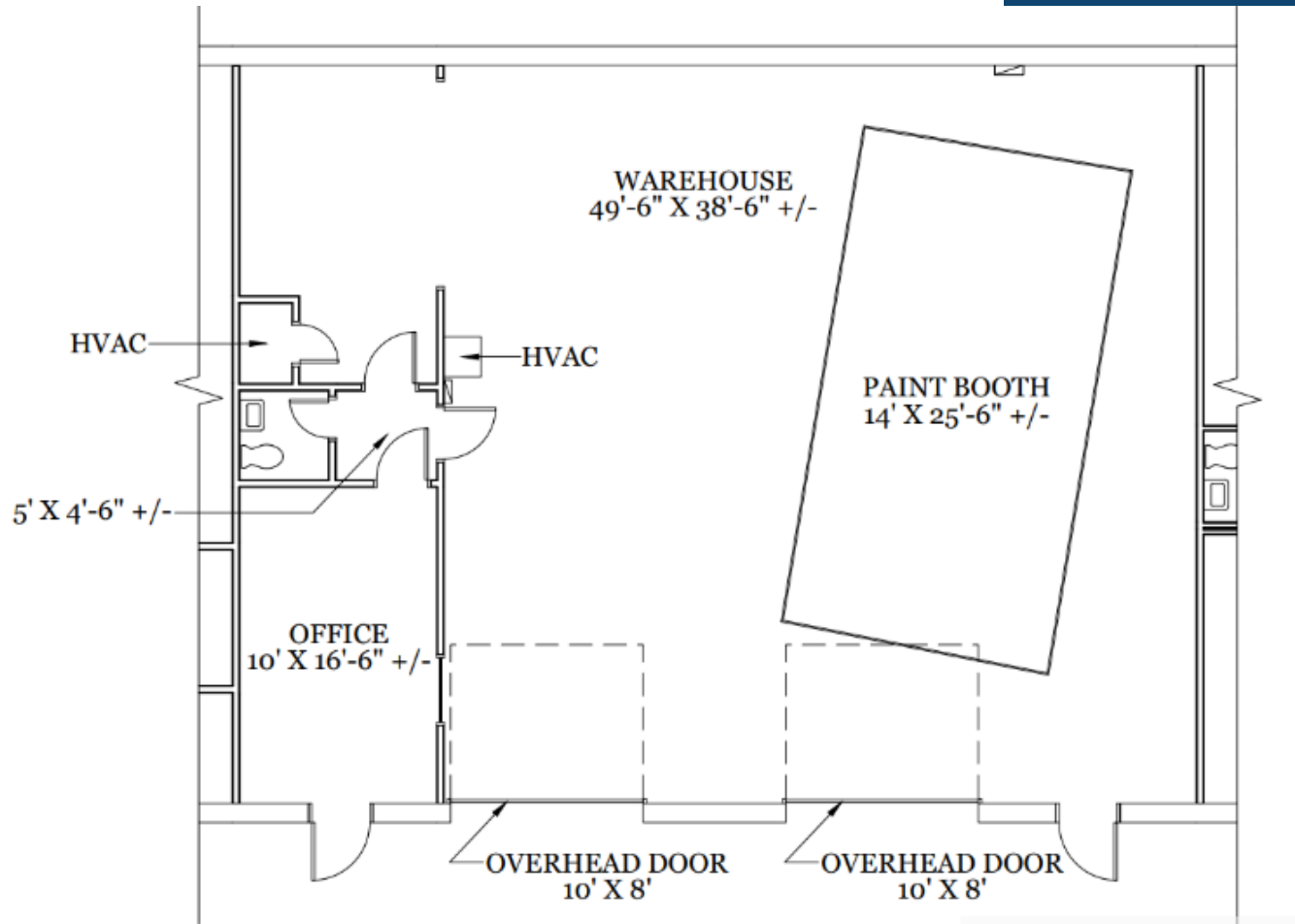

ALEX BRYAN
972.965.2878
alex@richyoungcompany.com

GARRETT GOLDSTEIN
214.364.0674
garrett@richyoungcompany.com

Owned and Managed by:



PIONEER PARKWAY

FOR LEASE



Available Space:

#22/23 - 1,400 SF

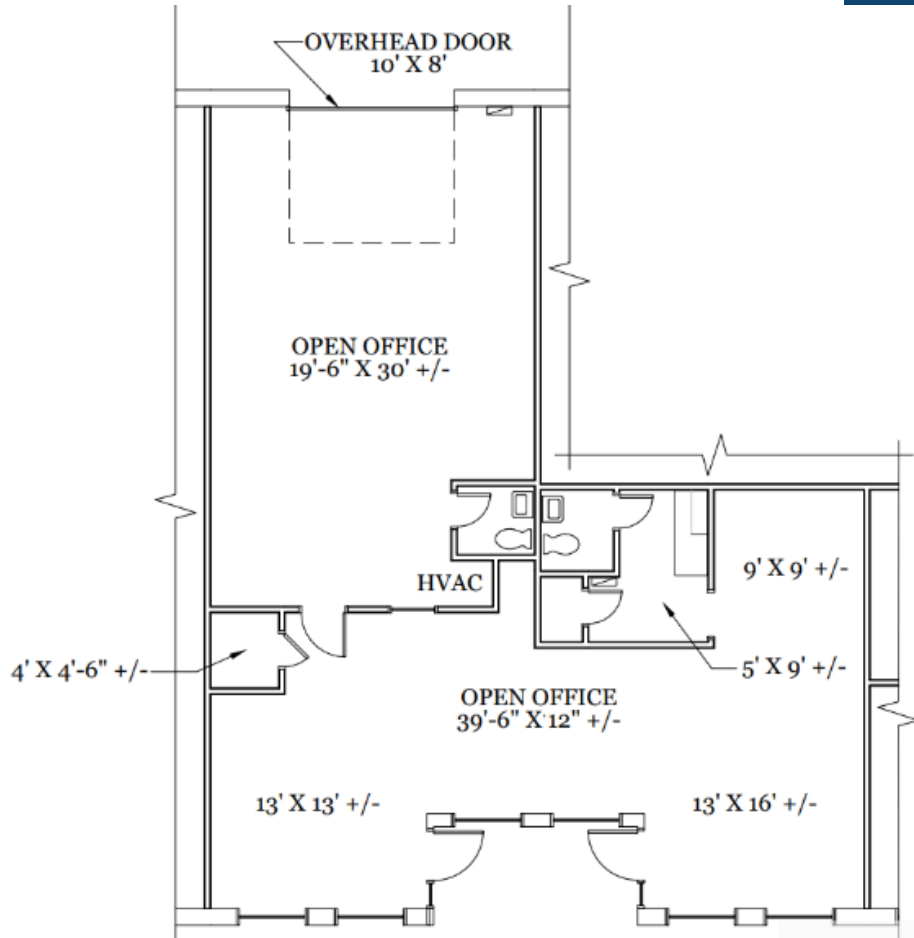

ALEX BRYAN
972.965.2878
alex@richyoungcompany.com

GARRETT GOLDSTEIN
214.364.0674
garrett@richyoungcompany.com

Owned and Managed by:



PIONEER PARKWAY

FOR LEASE



Available Space:

#30 - 2,250 SF

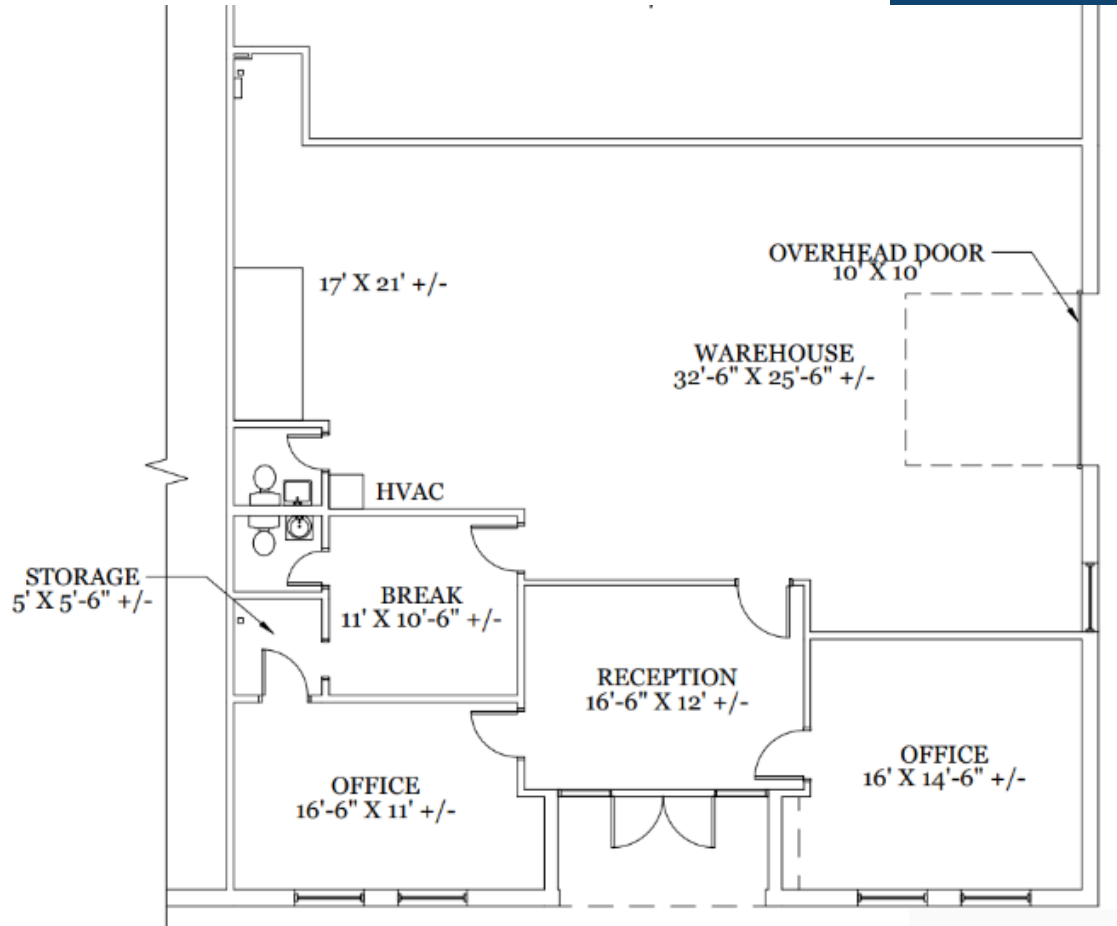

ALEX BRYAN
972.965.2878
alex@richyoungcompany.com

GARRETT GOLDSTEIN
214.364.0674
garrett@richyoungcompany.com

Owned and Managed by:



PIONEER PARKWAY

FOR LEASE

Available Space:

#3217A - 5,802 SF

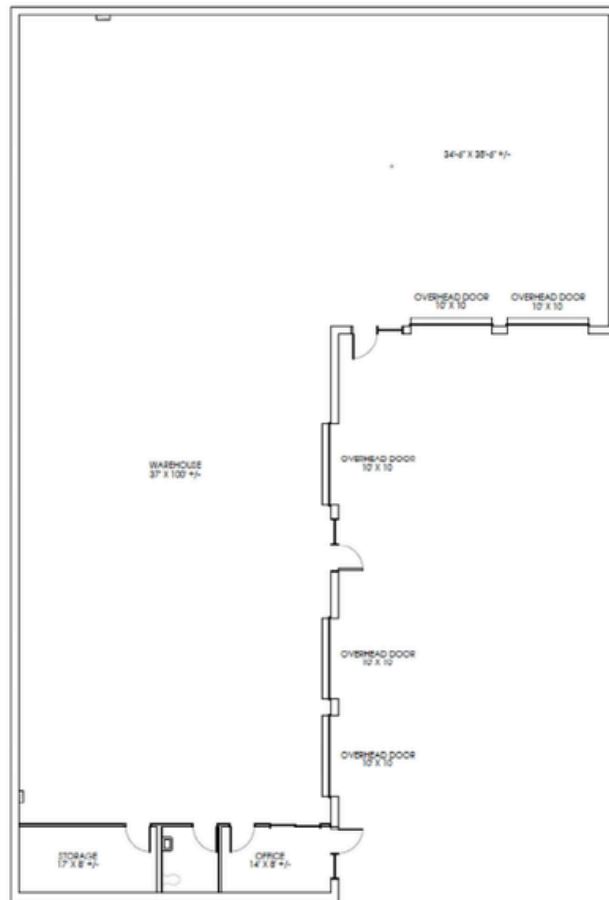

ALEX BRYAN
972.965.2878
alex@richyoungcompany.com

GARRETT GOLDSTEIN
214.364.0674
garrett@richyoungcompany.com

Owned and Managed by:



PIONEER PARKWAY

FOR LEASE



Available Space:

#38 - 1,000 SF

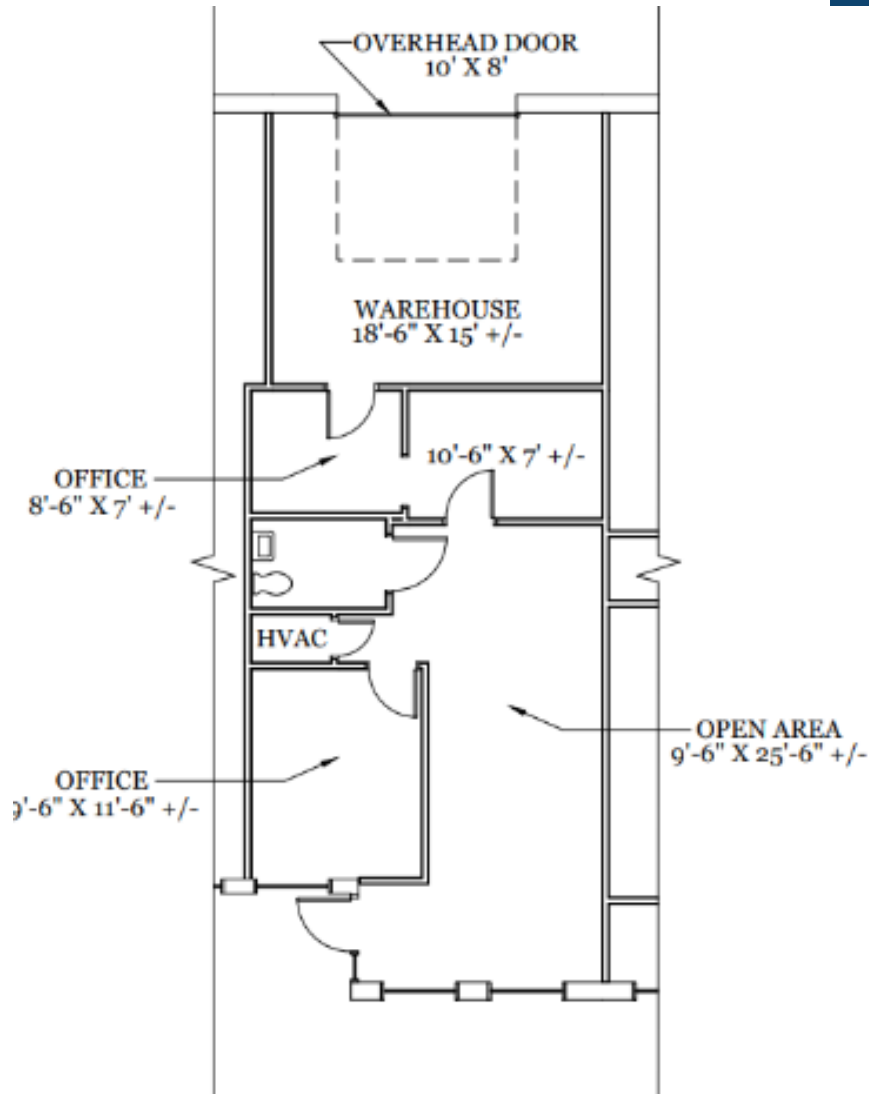

ALEX BRYAN
972.965.2878
alex@richyoungcompany.com

GARRETT GOLDSTEIN
214.364.0674
garrett@richyoungcompany.com

Owned and Managed by:



PIONEER PARKWAY

FOR LEASE



Available Space:

#39 - 1,000 SF

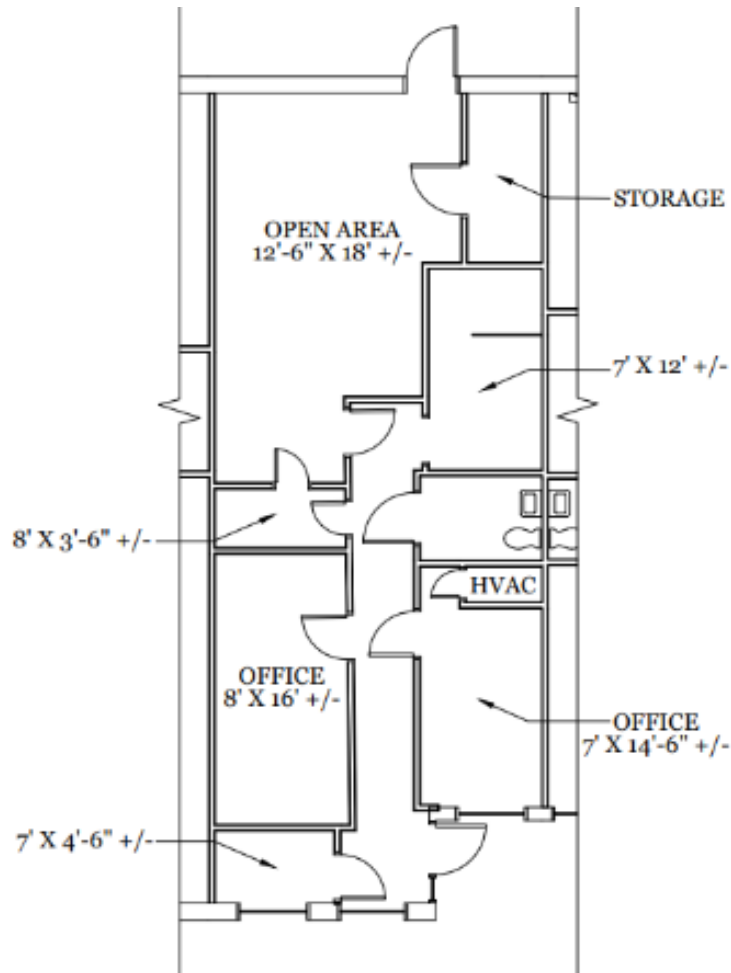

ALEX BRYAN
972.965.2878
alex@richyoungcompany.com

GARRETT GOLDSTEIN
214.364.0674
garrett@richyoungcompany.com

Owned and Managed by:



PIONEER PARKWAY

FOR LEASE



Available Space:

#44 - 1,600 SF

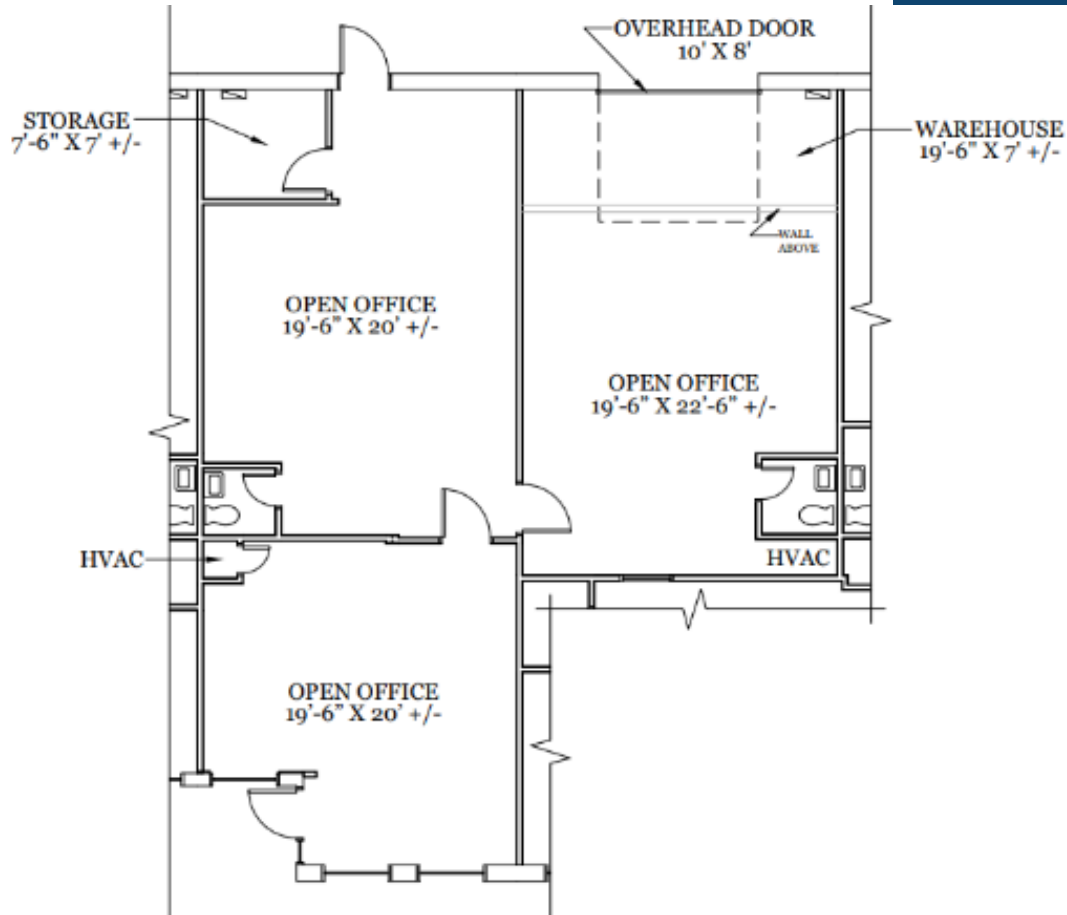

ALEX BRYAN
972.965.2878
alex@richyoungcompany.com

GARRETT GOLDSTEIN
214.364.0674
garrett@richyoungcompany.com

Owned and Managed by:



PIONEER PARKWAY

FOR LEASE



ALEX BRYAN
972.965.2878
alex@richyoungcompany.com

GARRETT GOLDSTEIN
214.364.0674
garrett@richyoungcompany.com

Owned and Managed by:



PIONEER PARKWAY

FOR LEASE



ALEX BRYAN
972.965.2878
alex@richyoungcompany.com

GARRETT GOLDSTEIN
214.364.0674
garrett@richyoungcompany.com

Owned and Managed by:



PIONEER PARKWAY

FOR LEASE



ALEX BRYAN
972.965.2878
alex@richyoungcompany.com

GARRETT GOLDSTEIN
214.364.0674
garrett@richyoungcompany.com

Owned and Managed by:

