

*3 Months Free Rent on 3 Year Leases  
& 6 Months Free Rent on 5 Year Leases*



# R&D SPACE FOR LEASE

*Multiple spaces available with  
convenient access to the BART/  
Caltrain Stations in Burlingame*

6, 14, 16, 18, 38 ADRIAN CT, BURLINGAME, CA



## Property Highlights

Double door access for shipping & receiving

2.9 miles to SFO

Walking distance to restaurants

US 101 frontage & visibility

### AVAILABILITIES

|              |           |
|--------------|-----------|
| 6 ADRIAN CT  | ±1,610 SF |
| 14 ADRIAN CT | ±1,610 SF |
| 16 ADRIAN CT | ±1,606 SF |
| 18 ADRIAN CT | ±1,763 SF |
| 38 ADRIAN CT | ±1,714 SF |

**\$2.25 NNN**  
ASKING RATE

**\$0.57**  
OPEX (\$/SF)

6, 14, 16, 18 & 38 ADRIAN CT

# HYPOTHETICAL R&D LAB CONVERSION

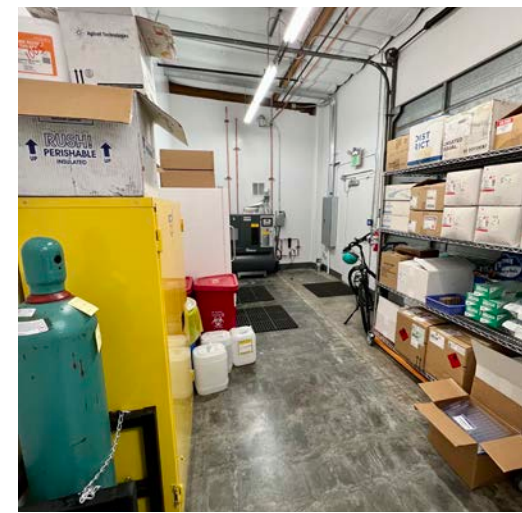
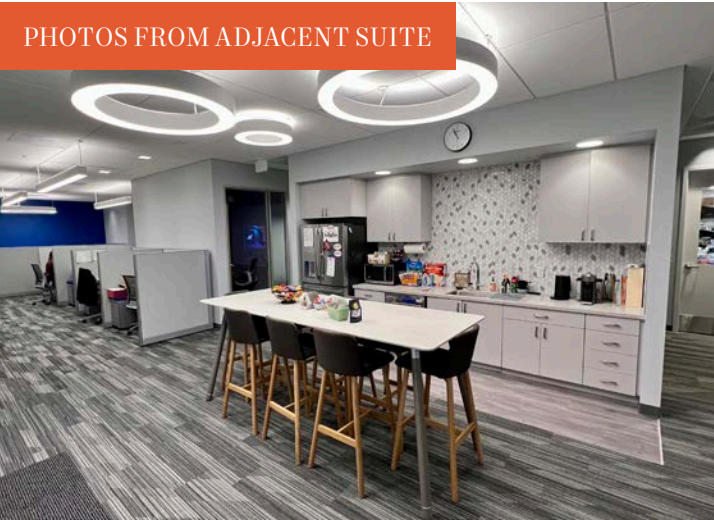

AVAILABLE FOR LEASE

KIDDER MATHEWS

# SITE PLAN

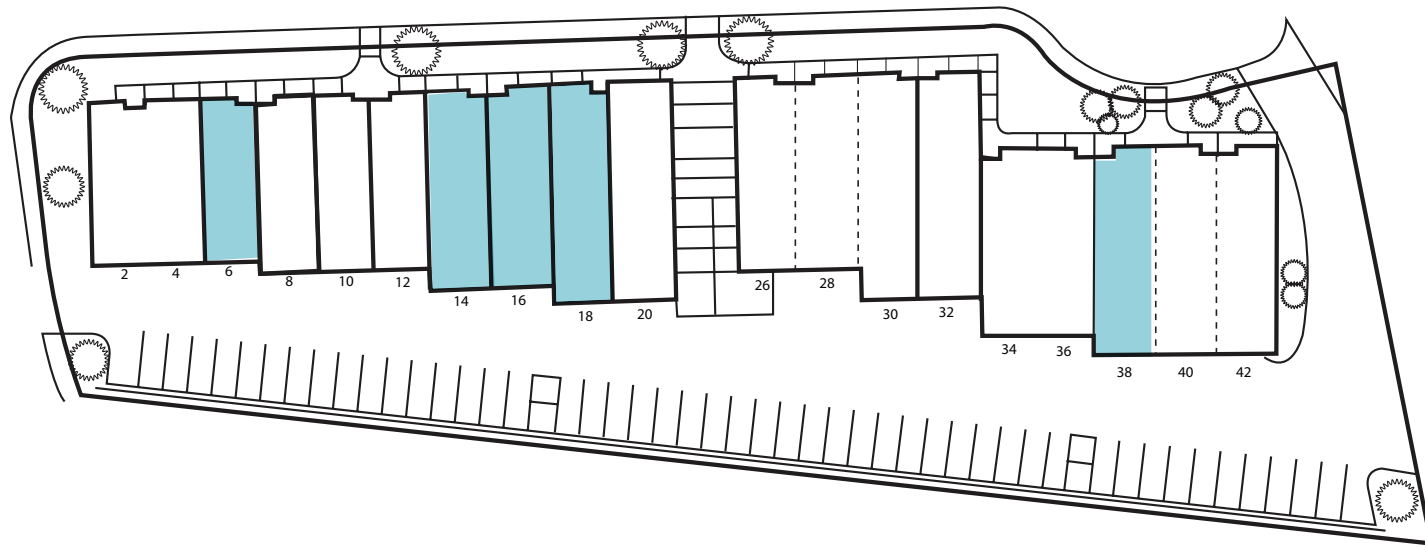

# SUITE 6

*1,610 SF*  
AVAILABLE

*NOW*  
AVAILABLE

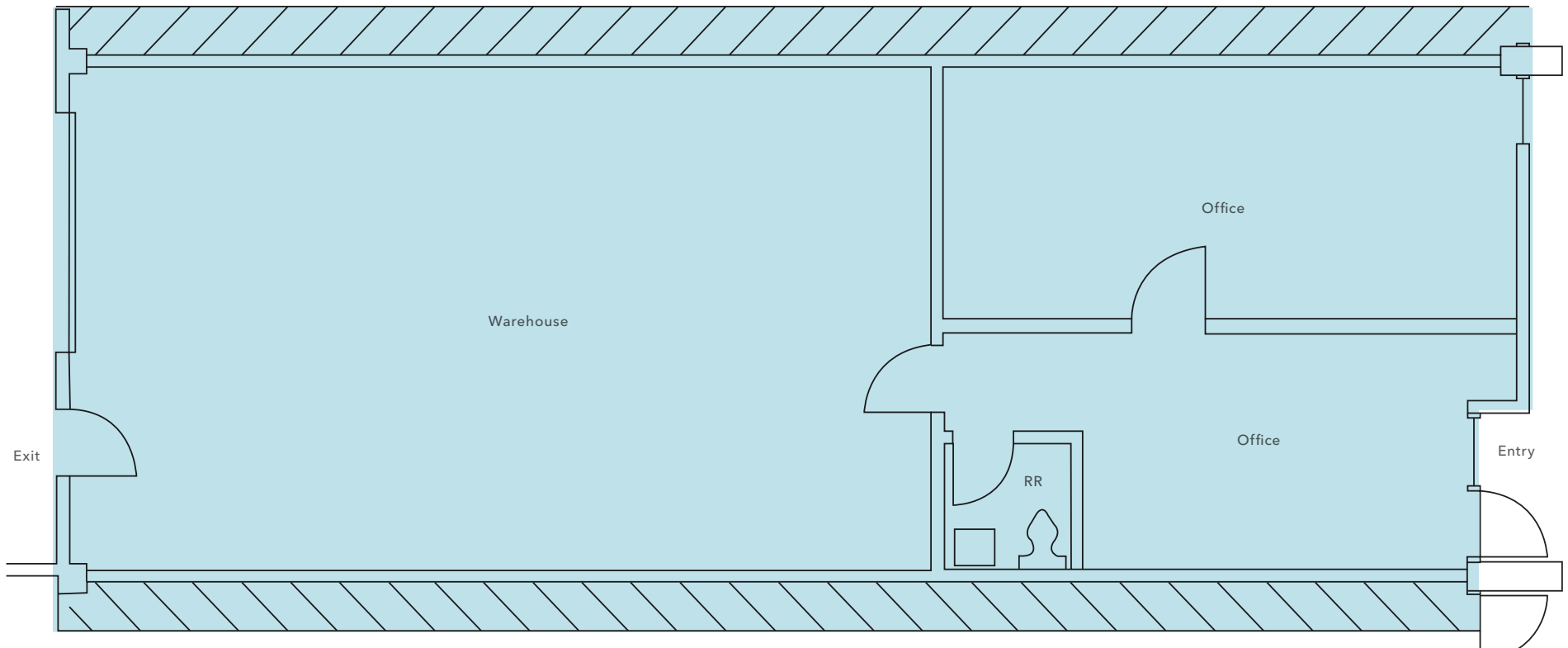

Floorplan not to scale

# SUITE 14

*1,610 SF*  
AVAILABLE

*NOW*  
AVAILABLE

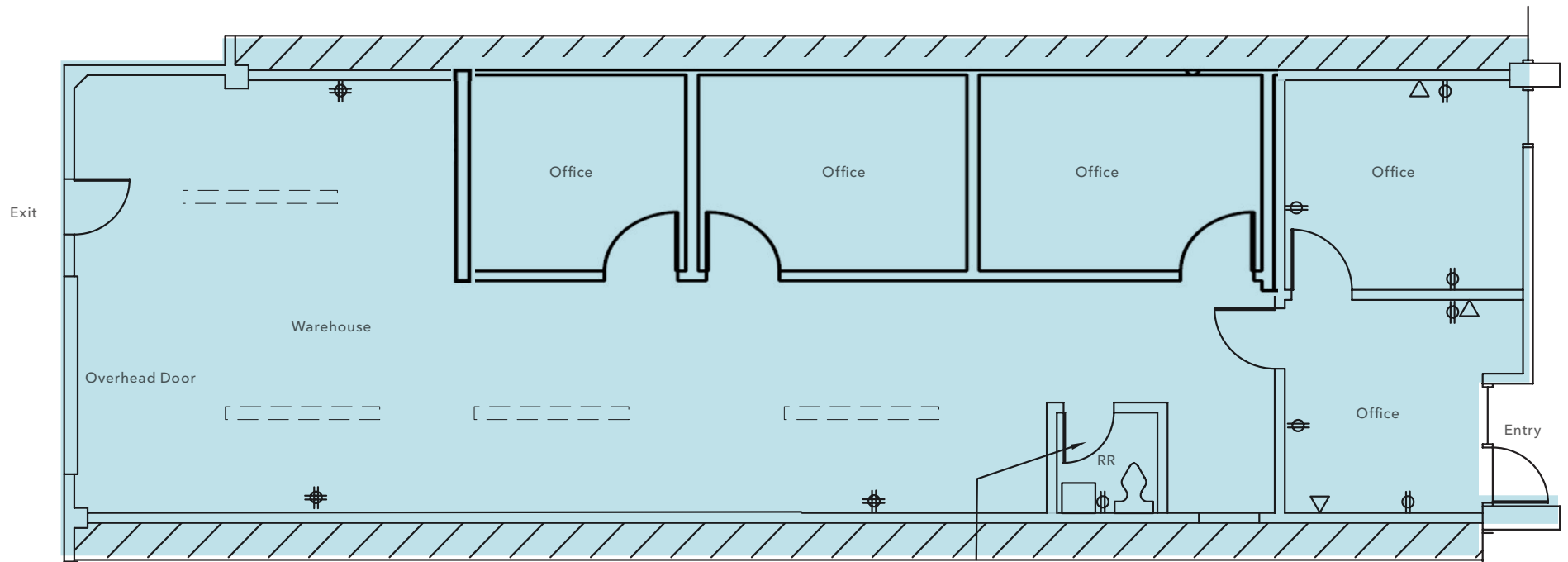

Floorplan not to scale

# SUITE 16

*1,606 SF*  
AVAILABLE

*NOW*  
AVAILABLE

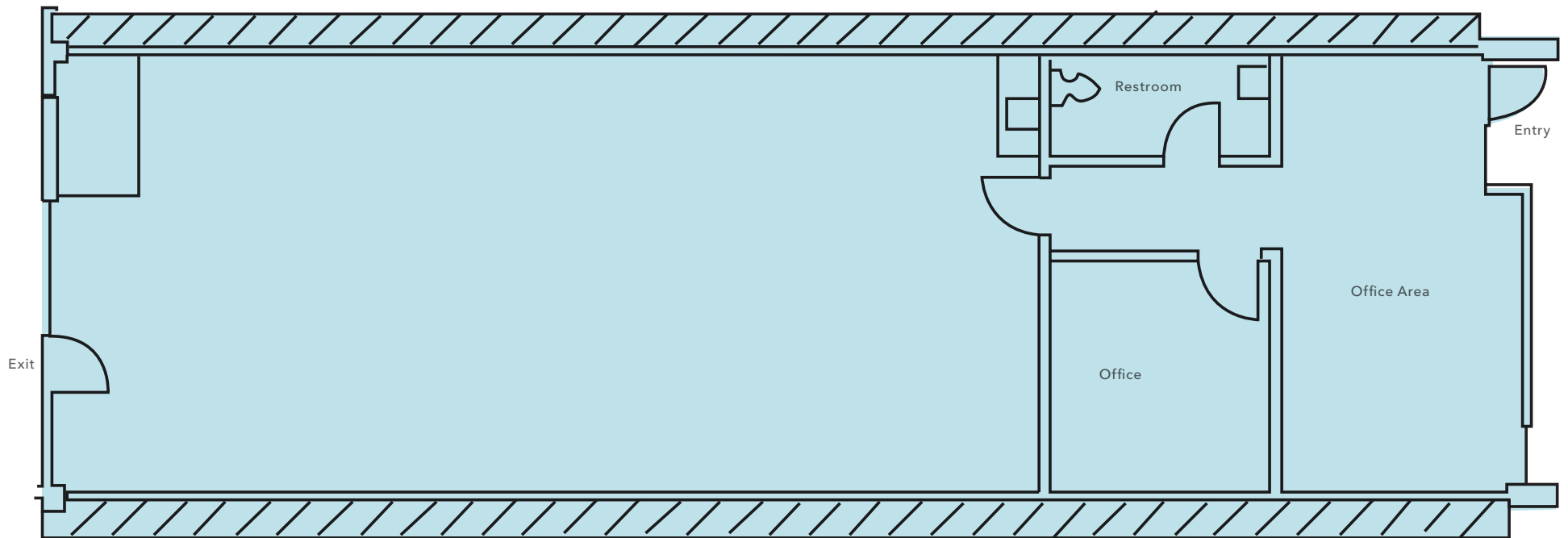

Floorplan not to scale

# SUITE 18

*1,763 SF*  
AVAILABLE

*NOW*  
AVAILABLE

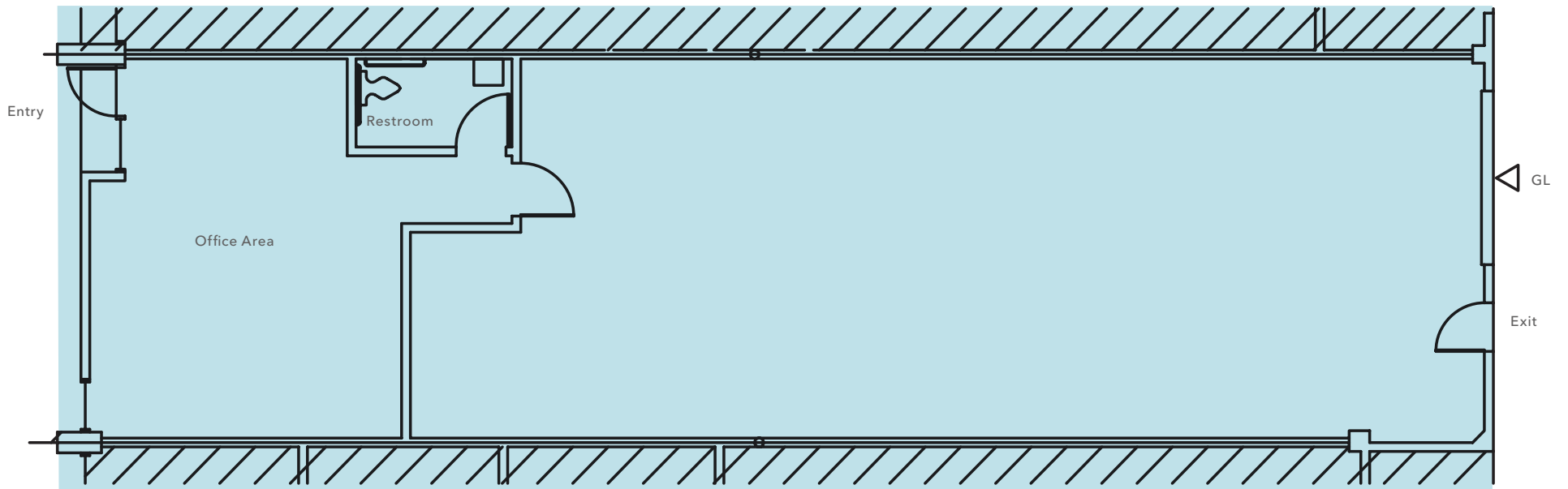

Floorplan not to scale



# SUITE 38

**1,714 SF**  
AVAILABLE

**NOW**  
AVAILABLE

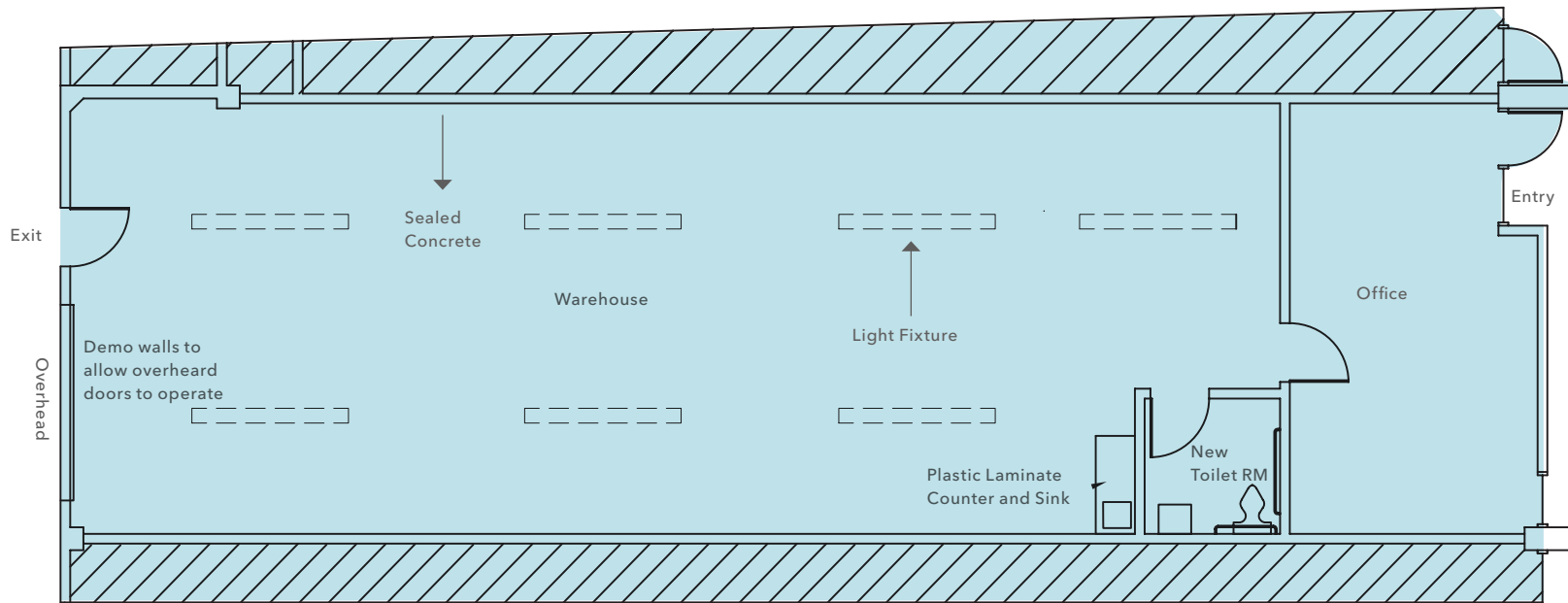

Floorplan not to scale

# HIGHLY- ACCESSIBLE LOCATION

Easy access to Hwy 101

Walkable to Bart/Caltrain

Minutes to San Francisco Int'l Airport

US 101 frontage & visibility



# 14, 16, 18 & 42 ADRAIN CT

*Exclusively leased by*

**BRETT WEBER**  
650.771.3000  
brett.weber@kidder.com  
LIC N° 01869489

**STEVE DIVNEY**  
650.400.8065  
steve.divney@kidder.com  
LIC N° 01216239

**JOHN MCLELLAN**  
415.418.9880  
john.mclellan@kidder.com  
LIC N° 01869489

**DREW RAMIREZ**  
650.430.1433  
drew.ramirez@kidder.com  
LIC N° 02209477

**KIDDER.COM**

This information supplied herein is from sources we deem reliable. It is provided without any representation, warranty, or guarantee, expressed or implied as to its accuracy. Prospective Buyer or Tenant should conduct an independent investigation and verification of all matters deemed to be material, including, but not limited to, statements of income and expenses. Consult your attorney, accountant, or other professional advisor.

