

R&D, Office | For Lease



CBRE

DOLLINGER PROPERTIES

Koll Business Park

San Jose, CA 95122

www.cbre.com/siliconvalley

±1,600 - ±2,540 SF





AVAILABLE SUITES

BUILDING	SUITE	SIZE	PRICE/SF	NOTES
1425	107	±2,000	\$1.50	90% Office. 10% Warehouse. GL Door
1430	105	±1,840	\$1.50	Partial Two-Story Unit
1435	104	±2,540	\$1.50	Partial 2-story. 25% Office, 70% Warehouse
1435	105	±2,340	\$1.45	50% Dropped Ceiling Office/50% Warehouse. GL Door. Partial Two-Story Unit
1435	108	±2,340	\$1.50	Partial 2-story, 40% HVAC Office, 60% Warehouse. GL Door
1445	107	±1,800	\$1.50	40% Office. 60% Warehouse. GL Door
1450	103	±2,540	\$1.50	Office. Warehouse. GL Door
1450	105	±2,540	\$1.50	30% Office. 70% Warehouse
1450	115	± 1,600	\$1.50	75% HVAC office. 25% Warehouse. GL Door
1450	116	± 1,600	\$1.50	75% HVAC office. 25% Warehouse. GL Door.

PROPERTY HIGHLIGHTS

- + Eleven Building Campus Totaling ±181,305 SF
- + Mix of Office and Industrial Units; Can Support Multiple Users
- + Close Proximity to San Jose International Airport
- + Short Walk to Light Rail Station on North First Street
- + Freeway Visibility
- + Easy Access from Highway 101

Floorplan

Koll Business Park
San Jose, CA 95122

1425 KOLL CIRCLE
SUITE 107
±2,000 SF

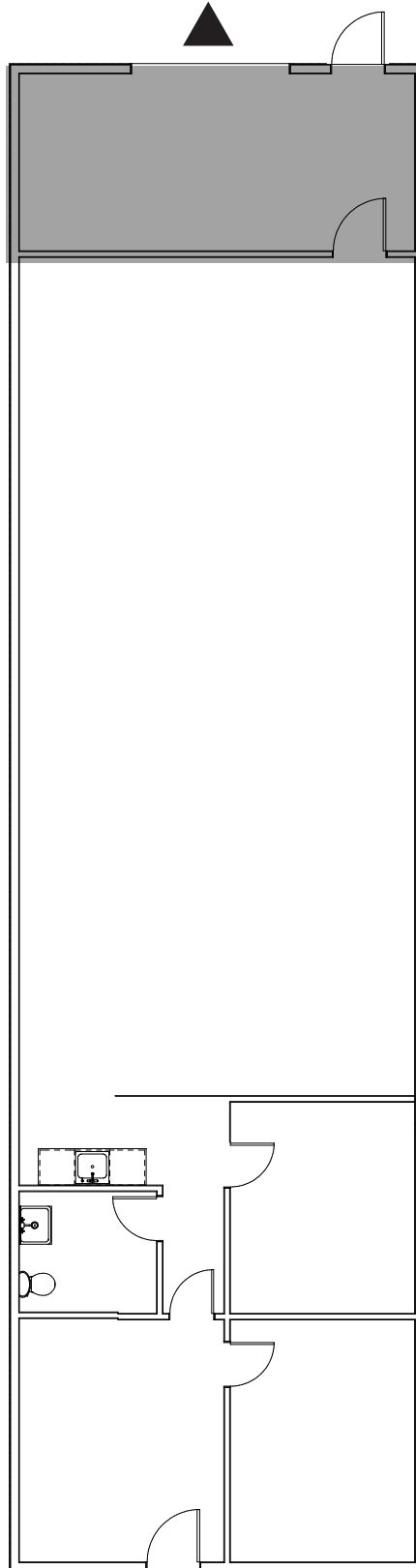

- WAREHOUSE
 - GRADE LEVEL DOOR
- NOT TO SCALE

Floorplan

Koll Business Park

San Jose, CA 95122

1430 KOLL CIRCLE

SUITE 105

±1,840 SF

 WAREHOUSE

 GRADE LEVEL DOOR

NOT TO SCALE

Floorplan

Koll Business Park

San Jose, CA 95122

1435 KOLL CIRCLE

SUITE 104

±2,540 SF

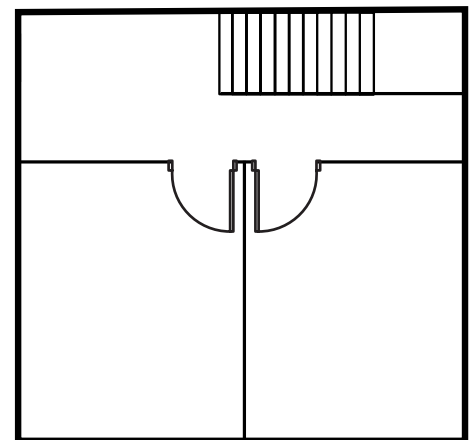
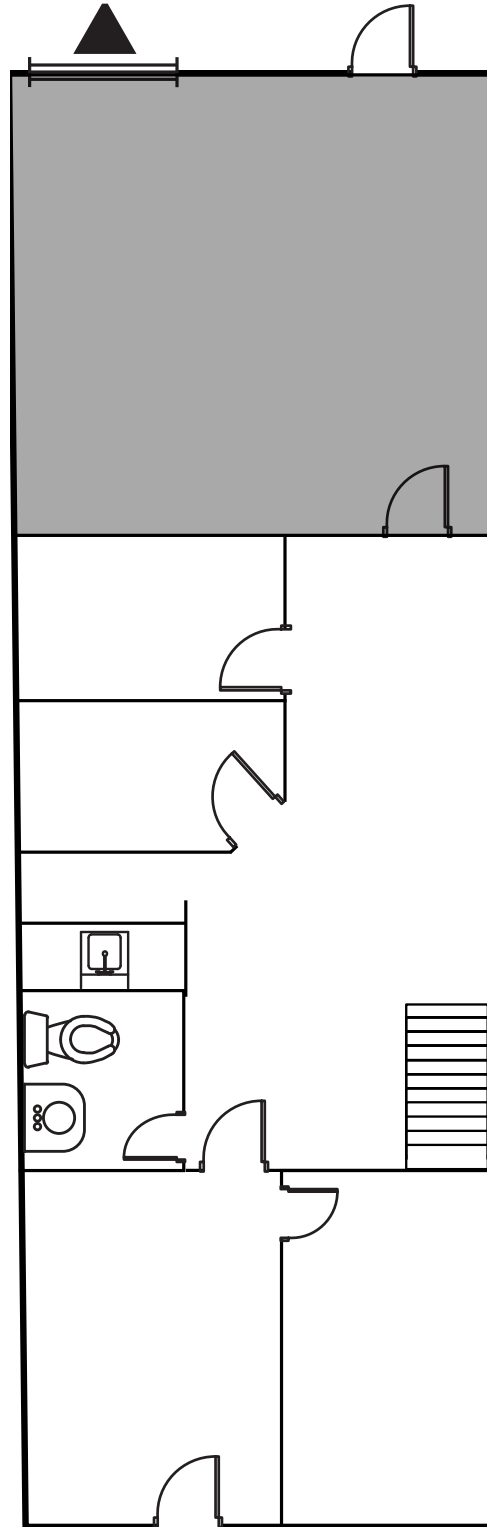

■ WAREHOUSE

▲ GRADE LEVEL DOOR

NOT TO SCALE

Floorplan

Koll Business Park
San Jose, CA 95122

1435 KOLL CIRCLE
SUITE 105
±2,340 SF

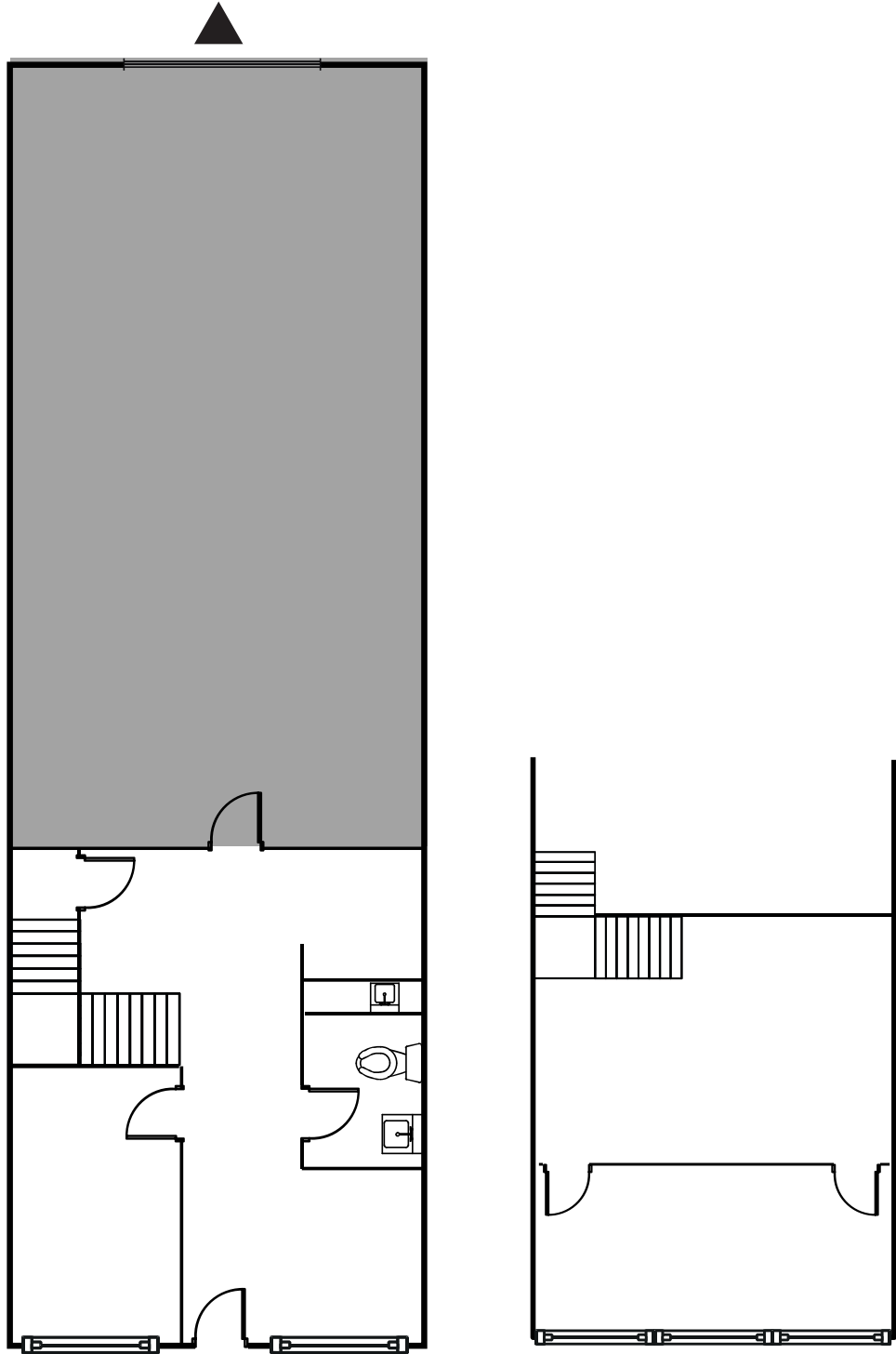

- WAREHOUSE
- ▲ GRADE LEVEL DOOR

NOT TO SCALE

Floorplan

Koll Business Park

San Jose, CA 95122

1435 KOLL CIRCLE
SUITE 108
±2,340 SF

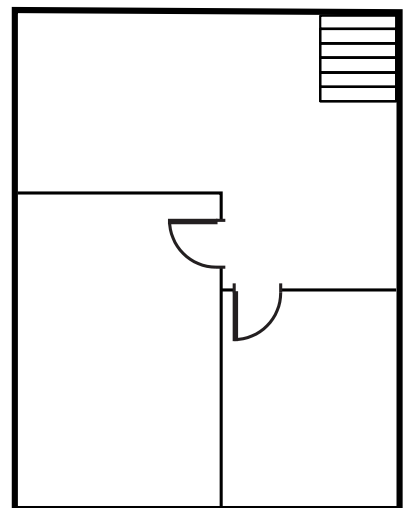
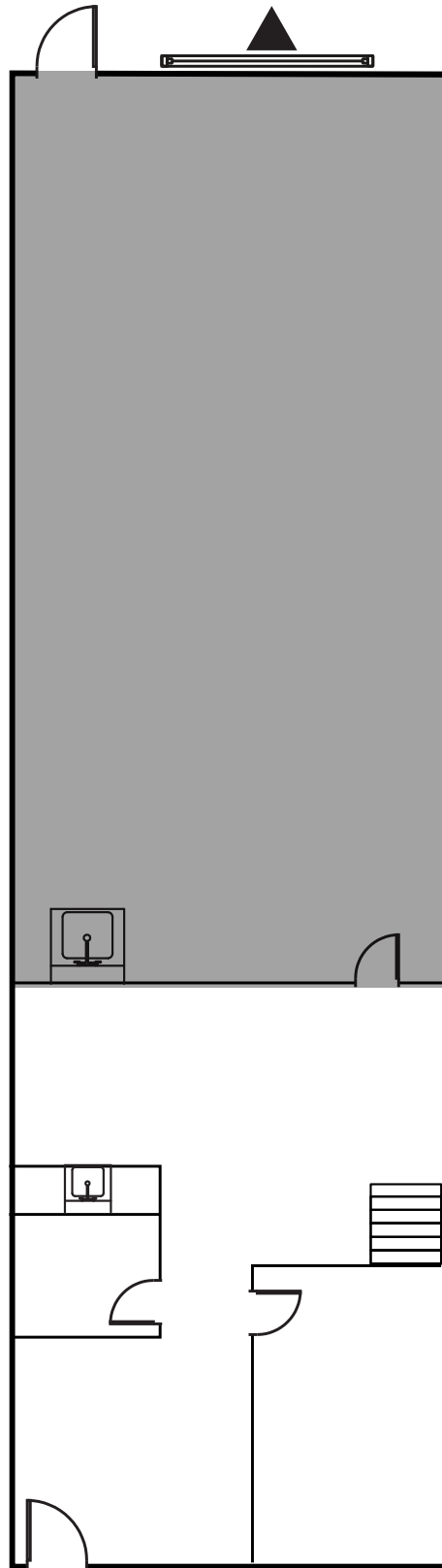

- WAREHOUSE
- ▲ GRADE LEVEL DOOR

NOT TO SCALE

Floorplan

Koll Business Park
San Jose, CA 95122

1445 KOLL CIRCLE
SUITE 107
±1,800 SF

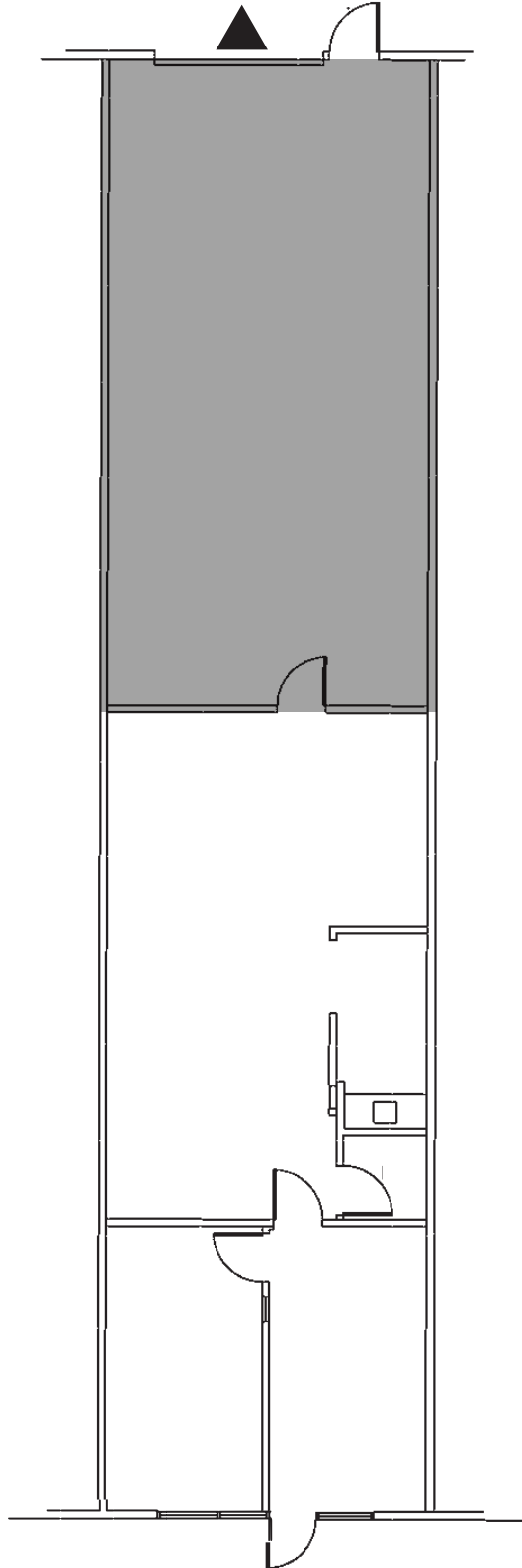

■ WAREHOUSE
▲ GRADE LEVEL DOOR

NOT TO SCALE

Floorplan

Koll Business Park
San Jose, CA 95122

1450 KOLL CIRCLE
SUITE 103
±2,540 SF

■ WAREHOUSE
▲ GRADE LEVEL DOOR
NOT TO SCALE

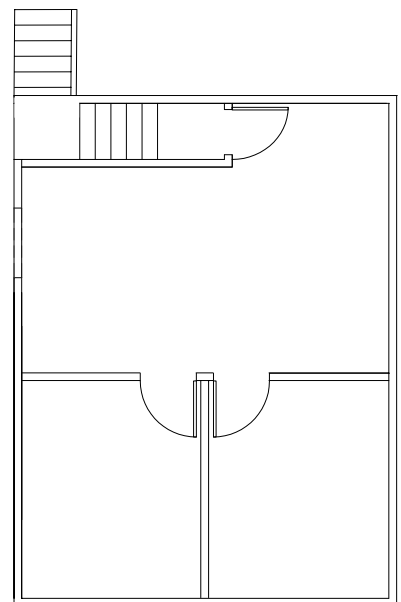
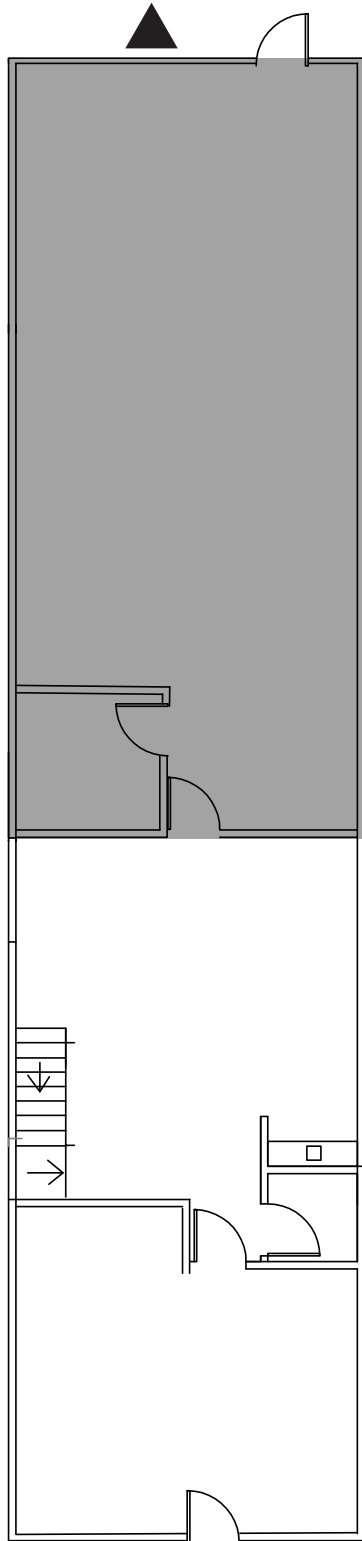

Floorplan

Koll Business Park
San Jose, CA 95122

1450 KOLL CIRCLE
SUITE 105
±2,540 SF

■ WAREHOUSE
▲ GRADE LEVEL DOOR
NOT TO SCALE

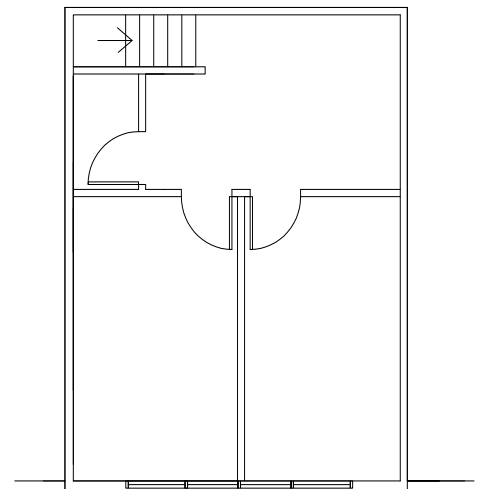
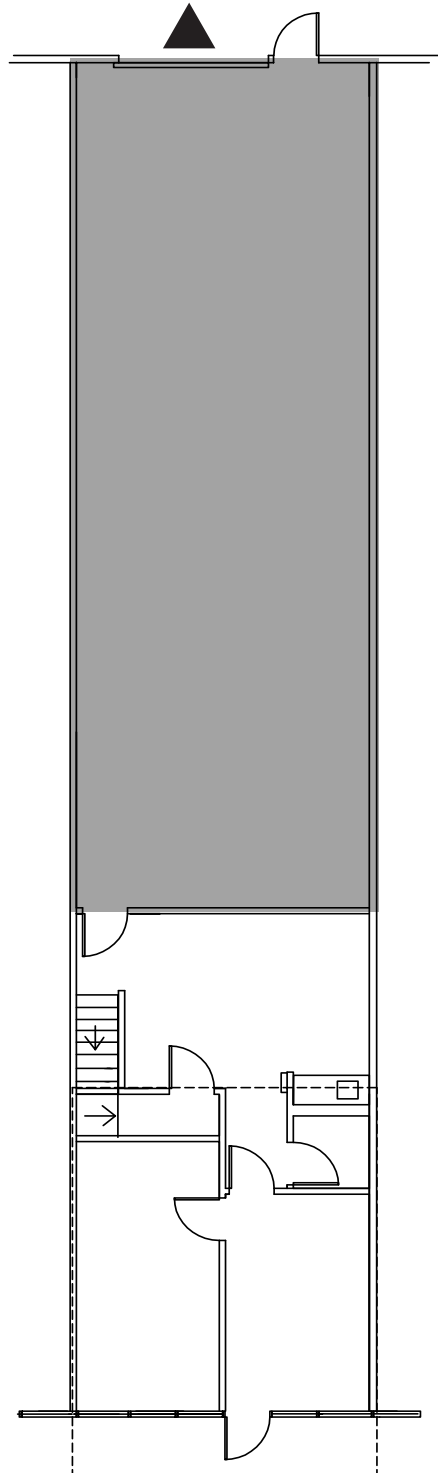

Floorplan

Koll Business Park
San Jose, CA 95122

1450 KOLL CIRCLE
SUITE 115
±1,600 SF

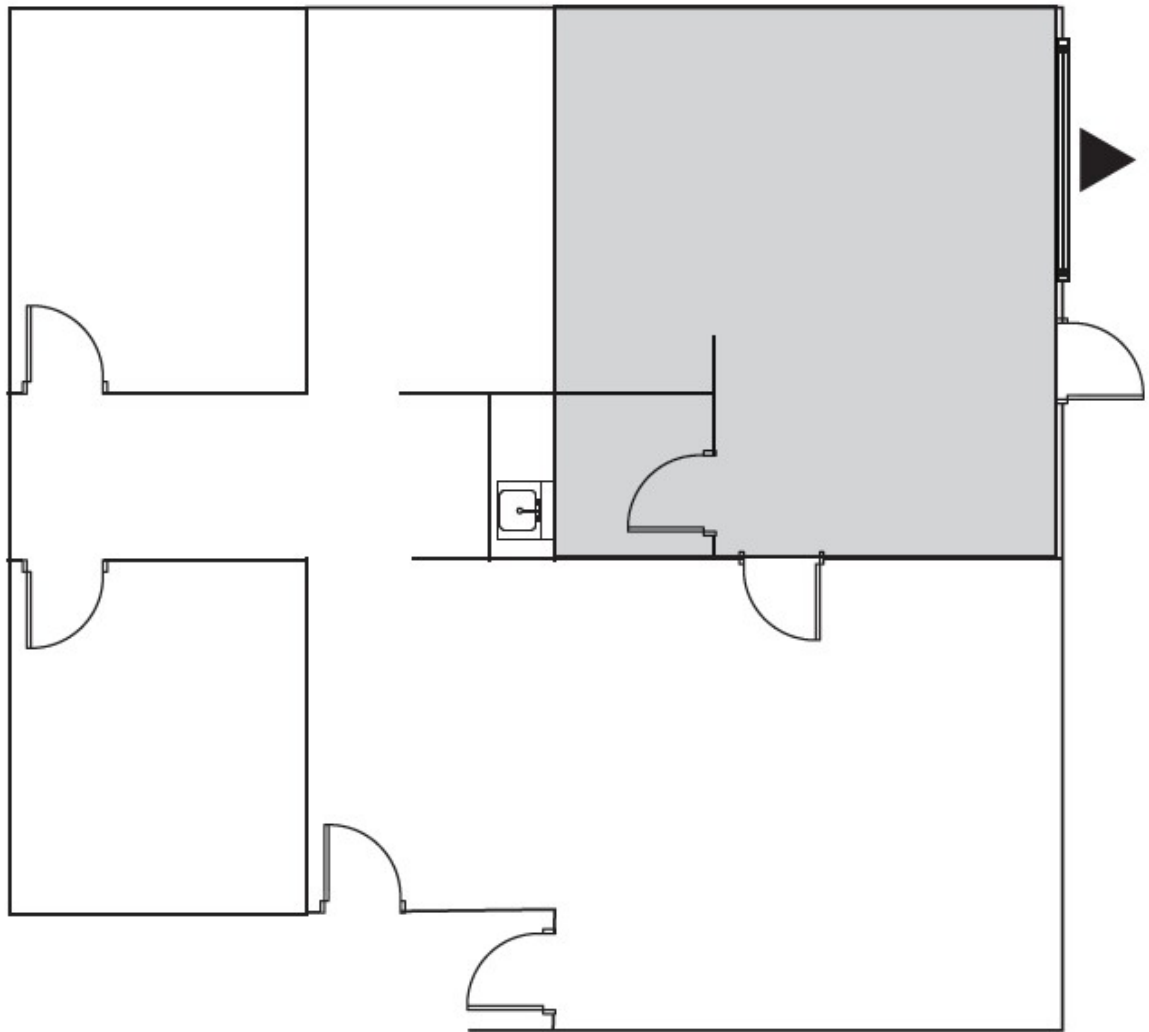

- WAREHOUSE
- ▲ GRADE LEVEL DOOR

NOT TO SCALE

Floorplan

Koll Business Park
San Jose, CA 95122

1450 KOLL CIRCLE
SUITE 116
±1,600 SF

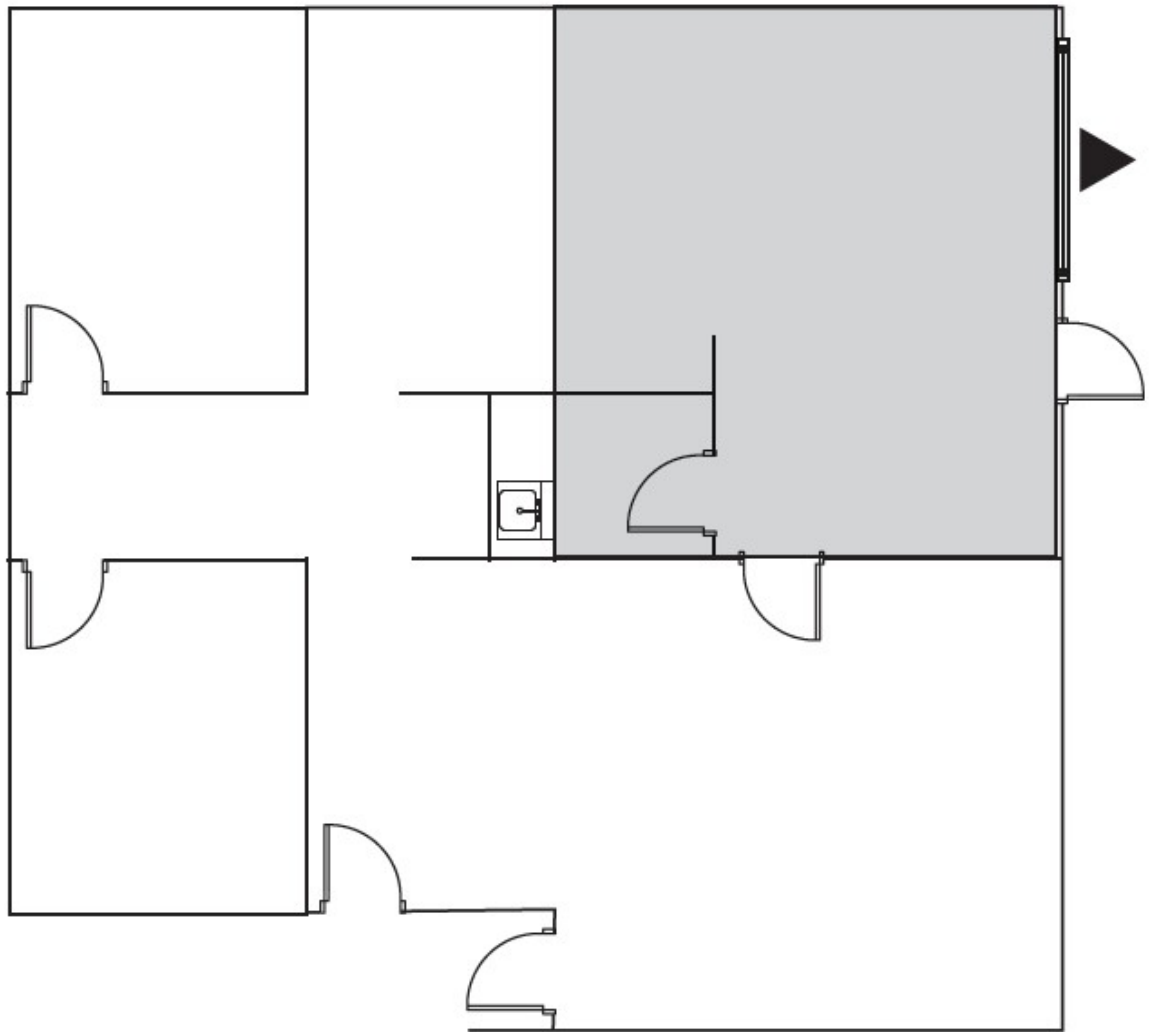

- WAREHOUSE
- ▲ GRADE LEVEL DOOR

NOT TO SCALE

Koll Business Park

San Jose, CA 95112

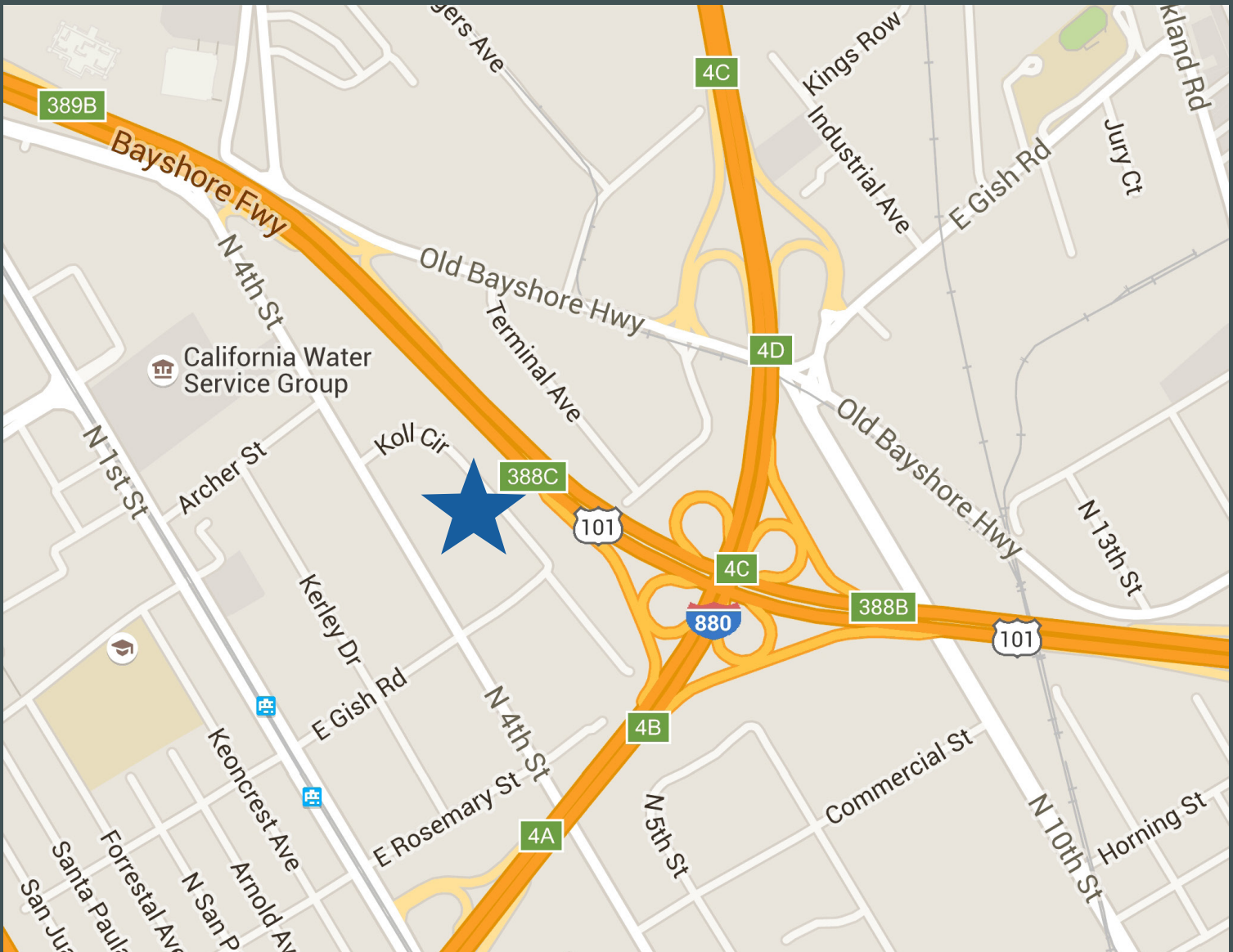

Contact Us

Paul Lyles

First Vice President
+1 408 453 7443
paul.lyles@cbre.com
Lic. 01236021

Robbie Taylor

Senior Vice President
+1 408 453 7489
robbie.taylor2@cbre.com
Lic. 01946325

© 2024 CBRE, Inc. All rights reserved. This information has been obtained from sources believed reliable but has not been verified for accuracy or completeness. CBRE, Inc. makes no guarantee, representation or warranty and accepts no responsibility or liability as to the accuracy, completeness, or reliability of the information contained herein. You should conduct a careful, independent investigation of the property and verify all information. Any reliance on this information is solely at your own risk. CBRE and the CBRE logo are service marks of CBRE, Inc. All other marks displayed on this document are the property of their respective owners, and the use of such marks does not imply any affiliation with or endorsement of CBRE. Photos herein are the property of their respective owners. Use of these images without the express written consent of the owner is prohibited.