

LEGAL DESCRIPTION

THE LAND REFERRED TO HEREIN BELOW IS SITUATED IN THE CITY OF LOS ANGELES, COUNTY OF LOS ANGELES, STATE OF CALIFORNIA, AND IS DESCRIBED AS FOLLOWS:
 POR OF LOT 4725, BLOCK 29, TRACT 6170, IN THE CITY OF LOS ANGELES, BOOK 86, PAGES 40-43 OF MAPS, IN THE OFFICE OF THE COUNTY RECORDER, APN: 2190-004-032

LEGEND	
	BOUNDARY LINE
	TREE
	CONC. BLOCK WALL
	SPOT ELEVATION
	CHAINLINK FENCE
	WOOD FENCE
	ASPHALT
	SEWER MANHOLE
	CENTER LINE

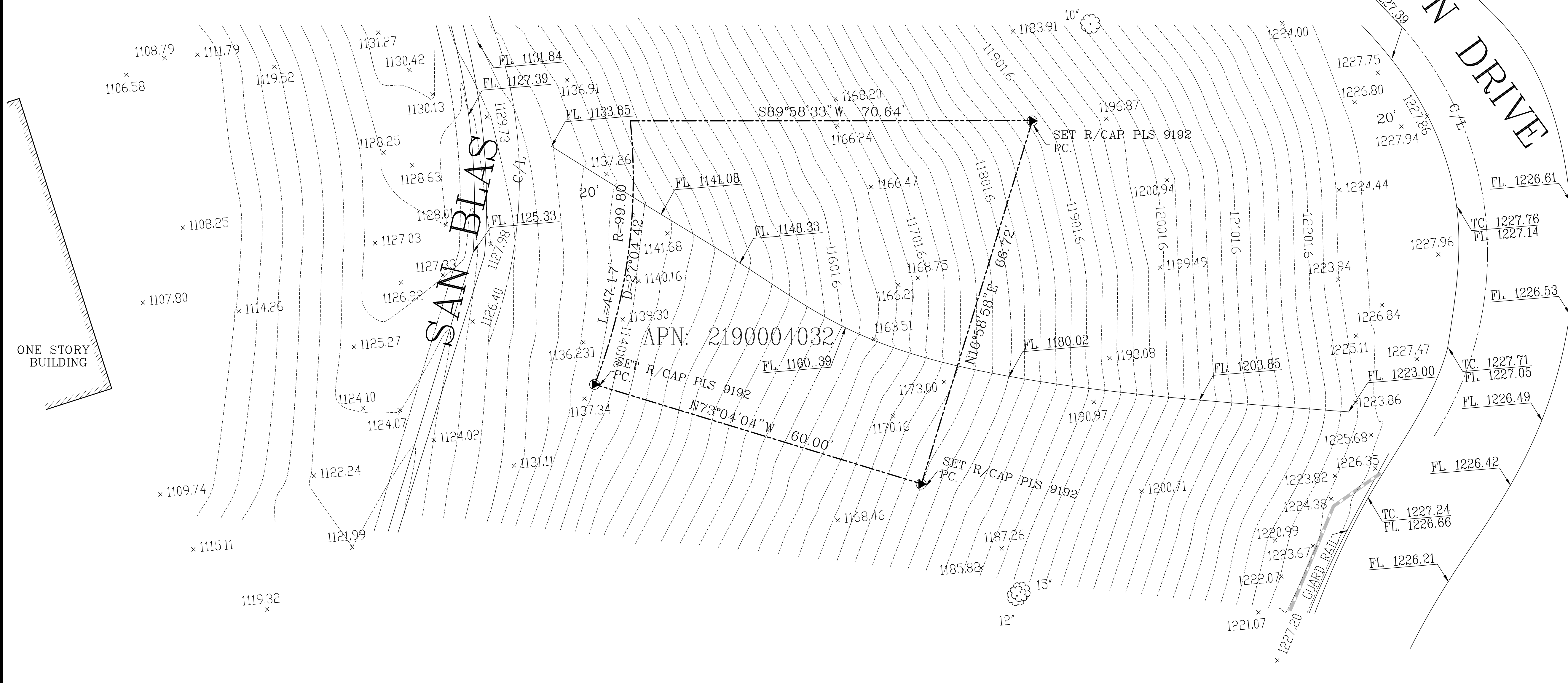

TOPOGRAPHY
SURVEY

PREPARED FOR:

 SAEID MOHAMMADI
 818-468-9920

NOTES:
 1. THE LEGAL DESCRIPTION, BOUNDARIES AND EASEMENT SHOWN HEREON ARE PER RECORD DATA
 2. MISC. DATA
 TOTAL PROPERTY AREA: 3550 SQ. FT.

 3. EASEMENTS ARE NOT PLOTTED.

BENCH MARK:
 STRUCTURE ID: 43905104
 ELEVATION=1095.80
 FD SMH @ CANOGA DRIVE

No.	Revision/Issue	Date

Firm Name and Address
 MOLAI LAND & DESIGN
 24308 BURBANK BLVD
 WOODLAND HILLS, CA 91367
 818-325-9225
 MOLAI22@YAHOO.COM

Project Name and Address

 APN. 2190004032

Project	4796	Sheet	1 OF 1
Date	09-11-2021		
Scale	1" = 10'		

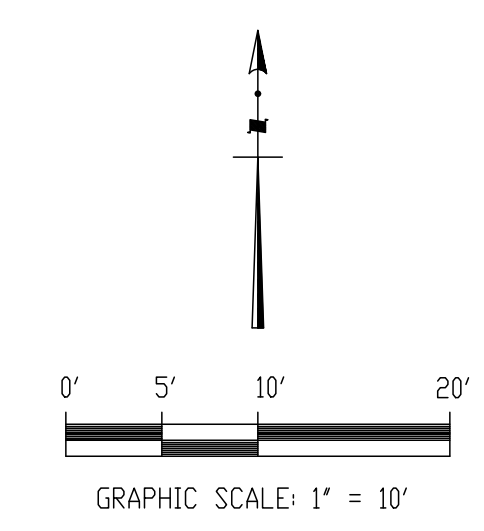

ONE STORY BUILDING