

SHOP SPACE AVAILABLE
INDIO PLAZA

NEC HIGHWAY 111 & MONROE STREET | INDIO, CA



±3,000, ±4,000 SF OR ±4,033 SF SHOP SPACES AVAILABLE

- Join Food 4 Less, dd's Discounts, Revivals, US Bank, Denny's, Rent A Center and many others at this busy neighborhood center in the heart of Indio
- Located at a prime intersection with easy access to Highway 111 and Monroe Street
- Monument Signage on Highway 111 and Monroe Street Available
- Ample parking

DEMOGRAPHICS	1MI	3MI	5MI
Population	24,483	101,524	170,382
Average Daytime Population	15,339	59,859	105,292
Average Household Income	\$60,904	\$100,978	\$101,984

Maggie Montez
 mmontez@leedesert.com
 760.346.2520
 LIC #01070683

Shawna Strange
 sstrange@leedesert.com
 760.346.2533
 LIC #01718495

73000 Highway 111, Suite 200 | Palm Desert, CA 92260 | www.LeePalmDesert.com | Corp ID # 01911964



SHOP SPACE AVAILABLE INDIO PLAZA

NEC HIGHWAY 111 & MONROE STREET | INDIO, CA



AVAILABLE RETAIL SPACE



UNIT #	TENANT	SIZE
118	US Bank (NAP)	7,200
120	Dennys	3,750
124	Food 4 Less	58,000
126A	Furniture	6,000
126B	Nailworks	1,600
128	Pho of the Desert	4,000
132	Aladinno's	±3,000
136	Available	±4,000
140	Sally's Beauty	12,000
144	Available	3,000
150	Revivals	±18,000
152	Available	±4,033
154	DD's Discounts	23,410
158	Check Advantage	1,300
162	Subway	1,200
166	CigZone	1,500
170	Flame Broiler	1,250
180 & 182	Don Roberto's	2,050
184	Donut	1,000

Maggie Montez
mmontez@leedesert.com
760.346.2520
LIC #01070683

Shawna Strange
sstrange@leedesert.com
760.346.2533
LIC #01718495

SHOP SPACE AVAILABLE
INDIO PLAZA

NEC HIGHWAY 111 & MONROE STREET | INDIO, CA



FLOOR PLANS

UNIT 136 4,000 SF

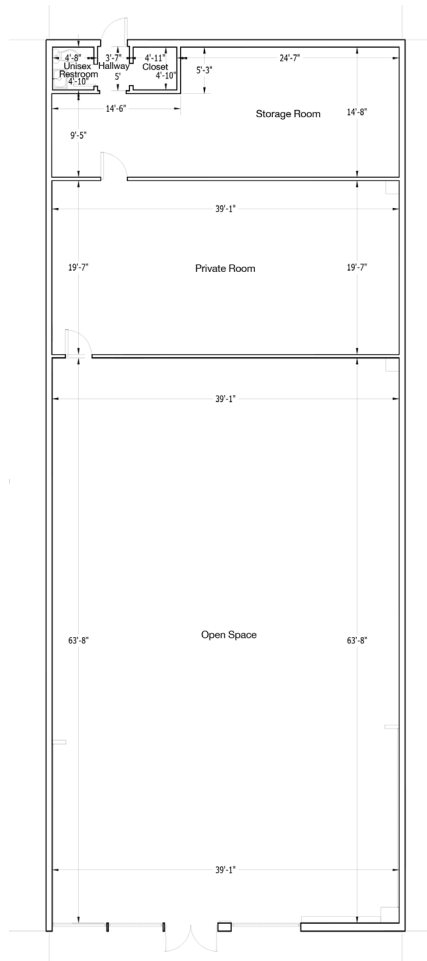

UNIT 152 4,033 SF

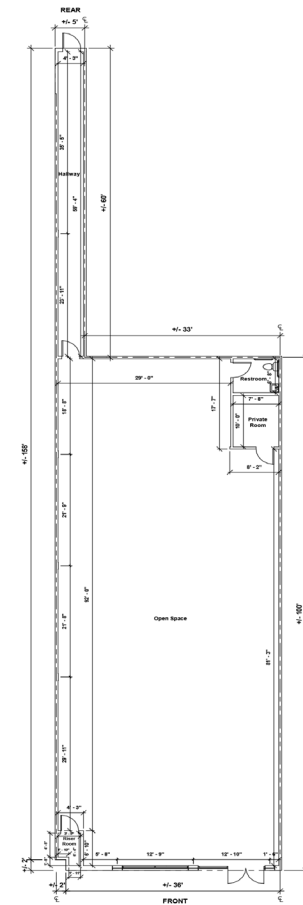

SHOP SPACE AVAILABLE INDIO PLAZA

NEC HIGHWAY 111 & MONROE STREET | INDIO, CA



Maggie Montez
mmontez@leedesert.com
760.346.2520
LIC #01070683

Shawna Strange
sstrange@leedesert.com
760.346.2533
LIC #01718495