

WOOD DESTROYING PESTS AND ORGANISMS INSPECTION REPORT

BUILDING NO. 3735-41	STREET, CITY, STATE, ZIP Madison Ave & 4548 38th St., San Diego CA 92116	Date of Inspection 2/5/2025	No. of Pages 7
--------------------------------	----------------------------------------------------------------------------------------	---------------------------------------	--------------------------



Termite and Pest Control (619) 462-5577
 (619) 462-1700 Fax
 3638 Bancroft Drive Spring Valley, CA 91977
 www.d-and-s-termite.com

Firm Registration No. PR 1164	Report No. 450116	Escrow No.
Ordered By: Canter Brokerage 7825 Faye Avenue, Ste 140 La Jolla, CA 92037 Attn: Mike Sugich	Property Owner/Party of Interest Canter Brokerage 7825 Faye Avenue, Ste 140 La Jolla, CA 92037 Attn: Mike Sugich	Report Sent To: Canter Brokerage 7825 Faye Avenue, Ste 140 La Jolla, CA 92037 Attn: Mike Sugich

COMPLETE REPORT
 LIMITED REPORT
 SUPPLEMENTAL REPORT
 REINSPECTION REPORT

General Description: Three one story four family structures, frame and stucco construction, composition roofs, attached and detached garages.

Inspection Tag Posted: Attics

Other Tags Posted:

An inspection has been made to the structure(s) shown on the diagram in accordance with the Structural Pest Control Act. Detached porches, detached steps, detached decks and any other structures not on the diagram were not inspected.

Subterranean Termites
 Drywood Termites
 Fungus/Dryrot
 Other Findings
 Further Inspection

If any of above boxes are checked, it indicates that there were visible problems in accessible areas. Read the report for details on checked items.

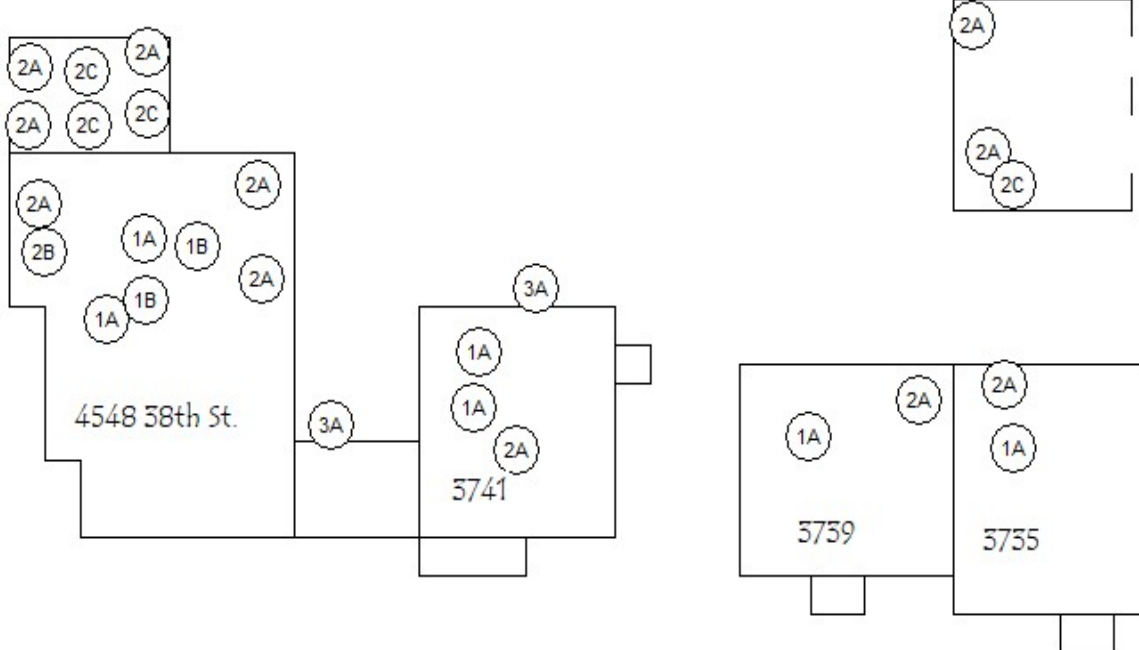

NOTE: Diagram not to scale. Findings in approximate locations.

Inspected by Mike R. Saunders State License No. OPR 5869 Signature _____

You are entitled to obtain copies of all reports and completion notices on this property reported to the Structural Pest Control Board during the preceding two years. To obtain copies contact: Structural Pest Control Board, 2005 Evergreen Street, Suite 1500, Sacramento, California 95815.

NOTE: Questions or problems concerning the above report should be directed to the manager of the company. Unresolved questions or problems with services performed may be directed to the Structural Pest Control board at (916) 561-8708, or (800) 737-8188 or www.pestboard.ca.gov. 43M-41 (Rev. 04/2015)

3735-41

Madison Ave & 4548 38th St., San Diego CA 92116

2/5/2025

450116

BUILDING NO.

STREET, CITY, STATE, ZIP

INSPECTION DATE

REPORT NO.

There are certain areas of the structure, which are considered impractical for inspection: furnished interiors; inaccessible attics or portions thereof; the interior of hollow walls, spaces between a floor or porch deck and the ceiling or soffit below; stall showers over finished ceilings; such structural segments as porte cocheres, enclosed bay windows, buttresses, and similar areas to which there is no access with out defacing or tearing out lumber, masonry or finished work; built-in cabinet work; abutments, or floors beneath coverings, areas where storage conditions, heavy vegetation or locks make inspection impractical. These areas (but not limited to) are considered inaccessible and were not inspected at this time. Note Appliances and/or plumbing over finished ceilings are not water tested and we do not certify against leakage, unless otherwise noted in this report. No evidence of leaks were noted in the roof covering system however, no opinion is rendered nor is guarantee implied concerning the future water tightness of the roof. This firm makes no guarantee against any infestation, leaks, or other adverse conditions which may exist or which may develop in inaccessible areas and become visibly evident after the date of this inspection. This inspection is only of the structures indicated on the diagram. Estimate and Report good for ninety days. **The exterior surface of the roof was not inspected. If you want the water tightness of the roof determined, you should contact a roofing contractor who is licensed by the Contractors State License Board.**

NOTICE:..Reports on this structure prepared by various registered companies should list the same findings (i.e. Termite infestations, termite damage, fungus damage etc.). However recommendations to correct these findings may vary from company to company.. You have a right to seek a second opinion from another company.

This company will reinspect repairs done by others within four months of the original inspection. A charge of half the original inspection fee will be charged for each re inspection. There inspection must be done within ten(10) working days of request. The re inspection is a visual inspection and if inspection of concealed areas in desired, inspection of work in progress will be necessary. Any guarantees must be received from parties performing repairs. Section 1993.1 S.P.C.B Rules & Regulations. This company will not certify eradication of termites completed by others.

Note: This wood destroying organisms report does NOT include mold or mold like conditions. Mold is NOT a wood destroying organism and is outside the scope of this report as defined by the Structural Pest Control Board Act Rules and Regulations. If you wish your property to be inspected for mold or mold like conditions, please contact the appropriate mold professional.

Our expert opinion limited, the source of moisture may be caused by factors unknown or unseen at the time of inspection. You are advised to contact an expert in the field of moisture conditions.

NOTE: D&S Termite inspectors are not equipped with second story ladders. We do not inspect any items over (12) twelve feet above ground level. D&S Termite can not be responsible for conditions existing above this level. Should you desire an inspection above our limits, we will schedule an appointment for an inspector properly equipped to do so. There may be an additional charge of \$250.00 for this service.

This is a separated report. Which is defined as section I and section II conditions evident on the date of inspection. Section I contains items where there is visible evidence of active infestation, infection or conditions that have resulted in or from infestation of infection. Section II items are conditions deemed likely to lead to infestation or infection but where no visible evidence of such was found. Further inspection items are defined as recommendations to inspect area(s) which during the original inspection did not allow the inspector access to complete the inspection and cannot be defined as Section I or Section II. Section 1990(f)S.P.C.B. Rules & Regulations.

3735-41

Madison Ave & 4548 38th St., San Diego CA 92116

2/5/2025

450116

BUILDING NO.

STREET, CITY, STATE, ZIP

INSPECTION DATE

REPORT NO.

1. Subterranean Termites:

FINDING 1A

FINDING: Evidence of subterranean termites and cellulose debris noted in subareas, see 1A on diagram.

RECOMMENDATION 1A

RECOMMENDATION: Remove and dispose of all loose cellulose debris, chemically treat (Termidor) soil of infested areas by trench method as needed for control of subterranean termites. Treatment guaranteed for one year.

***** This is a Section 1 Item *****

FINDING 1B

FINDING: Evidence of subterranean termites noted in attic of 4548 38th Street, see 1B on diagram.

RECOMMENDATION 1B

RECOMMENDATION: Remove and dispose of all loose cellulose debris, chemically treat (Termidor) soil of infested areas by trench method as needed for control of subterranean termites break down subterranean termite tubes as needed. Treatment guaranteed for one year.

***** This is a Section 1 Item *****

2. Drywood Termites:

FINDING 2A

FINDING: Evidence of drywood termites noted in sub areas, attics, garages and hardwood flooring, see 2A on diagram.

RECOMMENDATION 2A

RECOMMENDATION: Fumigate entire structure with lethal fumigant Sulfuryl Fluoride (VIKANE) Introduce Chloropicrin (tear gas) as needed as a warning agent. Fumigation will assure complete elimination of drywood termites, cover or clean up all visible and accessible pellets as needed. Fumigation notice and pesticide disclosure MUST be read and signed prior to injection of fumigant. Fumigation guaranteed for two years. **ALL FUMIGATIONS CANCELED LESS THAN 72 HOURS PRIOR TO SCHEDULED DATE WILL BE SUBJECT TO A CANCELLATION FEE OF 25% OF THE FUMIGATION COST.**

***** This is a Section 1 Item *****

FINDING 2B

FINDING: Evidence of drywood termite damage noted in 4548 38th Street hardwood flooring, see 2B on diagram.

RECOMMENDATION 2B

RECOMMENDATION: Remove and replace or repair drywood termite damage as needed. Work completed by D&S Termite guaranteed for one year. If certification is required D&S Termite must re inspect work completed by others. D&S Termite does not guarantee work completed by others. D&S Termite & Pest Control will apply primer coat, but cannot be responsible for match of color. If during the course of repair work, fungus and/or termite damage extends into inaccessible areas, there may be an additional charge for repairs. D&S Termite & Pest Control will contact you about additional charges if any.

***** This is a Section 1 Item *****

3735-41

Madison Ave & 4548 38th St., San Diego CA 92116

2/5/2025

450116

BUILDING NO.

STREET, CITY, STATE, ZIP

INSPECTION DATE

REPORT NO.

2. Drywood Termites:

FINDING 2C

FINDING: Evidence of drywood termite damage noted in garage framing, see 2C on diagram.

RECOMMENDATION 2C

RECOMMENDATION: Remove and replace or repair drywood termite damage as needed. Work completed by D&S Termite guaranteed for one year. If certification is required D&S Termite must re inspect work completed by others. D&S Termite does not guarantee work completed by others. D&S Termite & Pest Control will apply primer coat, but cannot be responsible for match of color. If during the course of repair work, fungus and/or termite damage extends into inaccessible areas, there may be an additional charge for repairs. D&S Termite & Pest Control will contact you about additional charges if any.

***** This is a Section 1 Item *****

3. Fungus/Dryrot:

FINDING 3A

FINDING: Fungus damage noted in window moulding and eaves, see 3A on diagram.

RECOMMENDATION 3A

RECOMMENDATION: Remove and replace or repair fungus damaged wood as needed. Work completed by D&S Termite guaranteed for one year. If certification is required D&S Termite must re inspect work completed by others. D&S Termite does not guarantee work completed by others. D&S Termite & Pest Control will apply primer coat, but cannot be responsible for match of color. If during the course of repair work, fungus and/or termite damage extends into inaccessible areas, there may be an additional charge for repairs. D&S Termite & Pest Control will contact you about additional charges if any.

***** This is a Section 1 Item *****

NOTICE: Under the Mechanic's Lien Law any structural pest control company which contracts to do work for you, any contractor, subcontractor, laborer, supplier or other person who helps to improve your property, but is not paid for his or her work or supplies, has the right to enforce a claim against your property. This means that after a court hearing, your property could be sold by a court officer and the proceeds of the sale used to satisfy the indebtedness. This can happen even if you have paid your own contractor in full, if the subcontractor, laborer, or supplier remains unpaid.

****NOTICE**** The charge for service that this company subcontracts to another registered company may include the company's charges for arranging and administering such services that are in addition to the direct costs associated with paying the subcontractor. You may accept D&S Termite Controls bid or you contract directly with another registered company licensed to perform the work.

If you choose to contract directly with another registered company, D&S Termite Control will not in any way be responsible for any act or omission in the performance of any work that you directly contract with another to perform.

3735-41	Madison Ave & 4548 38th St., San Diego CA 92116	2/5/2025	450116
BUILDING NO.	STREET, CITY, STATE, ZIP	INSPECTION DATE	REPORT NO.

This is not a clearance, estimate void after ninety days it may be necessary to revise prices after ninety days.

D&S Termite & Pest Control will waive inspection fee if authorized to do work.

NOTE: Itemized cost estimates are valid only if **ALL** work is completed by D&S Termite Control. Prices may vary if partial items are requested, call office for details.

*****NOTICE***ANY REQUEST TO ALTER OR CORRECT ANY PART OF THIS REPORT IS SUBJECT TO A \$30.00 ADMINISTRATIVE FEE, PAYABLE AT TIME OF REQUEST.*****

60mpi

AREAS INSPECTED:

- 1-SUB AREAS (soil conditions, accessibility, etc.)-dry accessible
- 2-STALL SHOWERS(water tested? leaks?)-overtubs no
- 3- FOUNDATIONS(type, relation to grade, etc.)-concrete
- 4-PORCHES-STEPS-concrete
- 5-VENTILATION(type, relation to grade, etc.)-adequate above grade
- 6-ABUTMENTS(stucco walls, columns, arches, etc.)-none
- 7-ATTICS(accessibility, insulation, etc.)-partially inaccessible due to insulation & construction
- 8-GARAGES(type, accessibility, etc.)-attached and detached
- 9-DECKS/PATIOS-none
- 10-INTERIOR-inspected
- 11-EXTERIOR-inspected

3735-41

Madison Ave & 4548 38th St., San Diego CA 92116

2/5/2025

450116

BUILDING NO.

STREET, CITY, STATE, ZIP

INSPECTION DATE

REPORT NO.

SECTION 1

SECTION 2

FURTHER INSPECTION

1A \$ 1400.00

1B See 1A

2A \$ 3760.00

2B \$ 3600.00

2C See 2B

3A See 2B

Proposed Cost Section 1: \$8,760.00

Proposed Cost Section 2: \$0.00

Proposed Cost Fur. Insp: \$0.00

3735-41	Madison Ave & 4548 38th St., San Diego CA 92116	2/5/2025	450116
BUILDING NO.	STREET, CITY, STATE, ZIP	INSPECTION DATE	REPORT NO.

OCCUPANTS CHEMICAL NOTICE

D & S Termite Control will use pesticide chemical(s) specified below for the control of wood destroying pests or organisms in locations identified in the Structural Pest Control report as indicated above.

(1) The pest(s) to be controlled:

SUBTERRANEAN TERMITES FUNGUS or DRY ROT
 BEETLES DRY-WOOD TERMITES OTHER

(2) The pesticide(s) proposed to be used and the active ingredient(s):

- A. Termidor. Active ingredients: Fipronil: 5-amino-1(2,6-dichlor-4-(trifluoromethyl)phenyl)-4-((1,r,s)-(trifluoromethyl)sulfinyl)-1H-pyrazole-3-carbonitrile....9.1% Inert ingredients..90.9%
B. VIKANE: Active ingredients: Sulfuryl Fluoride....99.8% -Inert ingredients:....02%
C. Chlor-O-Pic (Chloropicrin) Active ingredients: Chloropicrin 96.5% Other halonitroalkanes 3.5%
D. W/B Copper-Green-Active ingredients: Copper Napthenate 10.0% inter ingredients 90.0%

"State law requires that you be given the following information: CAUTION—PESTICIDES ARE TOXIC CHEMICALS. Structural Pest Control Companies are registered and regulated by the Structural Pest Control Board, and apply pesticides which are registered and approved for use by the California Department of Pesticide Regulation and the United States Environmental Protection Agency. Registration is granted when the state finds that, based on existing scientific evidence, there are no appreciable risks if proper use conditions are followed or that the risks are outweighed by the benefits. The degree of risk depends upon the degree of exposure, so exposure should be minimized.

"If within 24 hours following application you experience symptoms similar to common seasonal illness comparable to the flu, contact your physician or poison control center (1-619-692-8499) and your pest control company immediately."

In the case of Vikane: If within 24 hours you experience symptoms of dizziness, headache, nausea, reduced awareness, slowed movement, garbled speech or difficulty in breathing, leave the structure immediately and seek medical attention by contacting your physician or Poison Control Center (619) 692-8499 and notify your pest control company. The warning agent, chloropicrin, can cause symptoms of tearing, respiratory distress and vomiting. Entry into the space during fumigation can be fatal.

For further information, contact any of the following:

- D & S TERMITE CONTROL (619) 462-5577
SAN DIEGO COUNTY HEALTH DEPARTMENT (619) 338-2284/(858) 565-5255
SAN DIEGO COUNTY AGRICULTURE COMMISSIONER..... (858) 694-8980
POISON CONTROL CENTER (619) 692-8499
STRUCTURAL PEST CONTROL
2005 Evergreen Street, Suite 1500, Sacramento, CA 95815-3831 ... (800) 737-8188

Persons with respiratory or allergic conditions, or others who may be concerned about their health relative to this chemical treatment, should contact their physician concerning occupancy during and after chemical treatment prior to signing this NOTICE.

NO CHEMICAL APPLICATION WILL BE PERFORMED UNTIL SUCH TIME THAT THIS NOTICE IS RETURNED. HAVING READ THE INSTRUCTIONS, I, THE UNDERSIGNED, WILL ACCEPT RESPONSIBILITY FOR ALL THE AFOREMENTIONED.

OWNER/OCCUPANT _____ DATE _____