

June 21, 2022

Mr. Victor Lofquist, PE  
Lofquist & Associates, Inc.  
11 Citrus Drive  
Sylva, NC 28779

Re: Lyle Wilson Road Single Family Subdivision ("Elevate") - Cullowhee, North Carolina  
Letter of Confirmation and Construction Information

Dear Mr. Lofquist:

This letter is to serve as confirmation that Western Carolina University (WCU) can provide electric service to the above referenced development.

Pursuant to your request for service, we offer this service subject to the following:

1. WCU will require appropriate easements. The easements must hold WCU, its successors and assigns, harmless for damage and/or repair of paving, landscaping and fences as a result of system installation and/or future maintenance and repair.
2. WCU will require all roads and other properties where poles, cables, etc. are to be installed to be at final grade prior to installation.
3. The customer, will provide the necessary trench, backfill and/or select backfill for all underground cables. All trench work performed shall be in accordance with WCU's plans and specifications (see attached) and subject to WCU's inspection and approval.
4. For safety purposes, water lines, sewer lines, and/or other underground facilities installed parallel to WCU's underground electrical cables should maintain a minimum horizontal separation of six (6) feet from the cables, unless specifically exempted. When water lines, sewer lines, and/or other underground installations cross WCU's electrical cables, a minimum vertical separation of twelve (12) inches should be maintained.
5. The customer is required to pay to WCU the estimated difference in cost between any requested underground service and the overhead service which would normally be provided. The differential cost for underground electrical service will be determined once plans are finalized and a formal request for electrical service is received. Once this is received, a Special Work Request/Agreement (see attached) will need to be developed and executed prior to the start of any utility construction.

If we can be of further assistance, please advise.

Very truly yours,

A handwritten signature in black ink, appearing to read "Joe Walker". The signature is fluid and cursive, with a long horizontal stroke at the end.

Joe Walker, P.E.  
Associate Vice Chancellor for Facilities Management  
Western Carolina University

Enclosures:     Underground Trench Specifications  
                      Special Work Request/Agreement

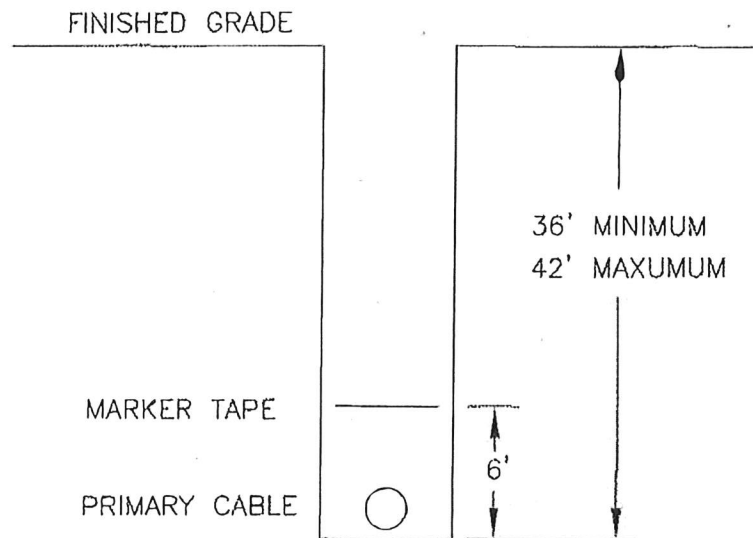

NOTE:

- 1.) TRENCH TO BE FREE OF ROCKS AND ROOTS
- 2.) SELECT BACKFILL TO BE USED TO FILL TRENCH.  
IF SOIL IS ROCKY, CUSTOMER IS RESPONSIBLE  
FOR PROVIDING ROCK FREE BACKFILL.
- 3.) BACKFILL TO BE TAMPED TO PREVENT WASHING  
AND SETTLING.
- 4.) MAINTAIN 12' MINIMUM SEPARATION WHEN CROSSING  
OVER OR UNDER WATER AND SEWER LINES.
- 5.) PRIMARY CABLES ARE NOT TO BE ENERGIZED  
BEFORE TRENCH IS BACKFILLED TO FINISHED GRADE.

## PRIMARY TRENCH DETAIL

NOT TO SCALE: 06-17-22 JHW

TO SCHEDULE

TRENCHING CALL- RANDY

FOX AT (828) 227-3203

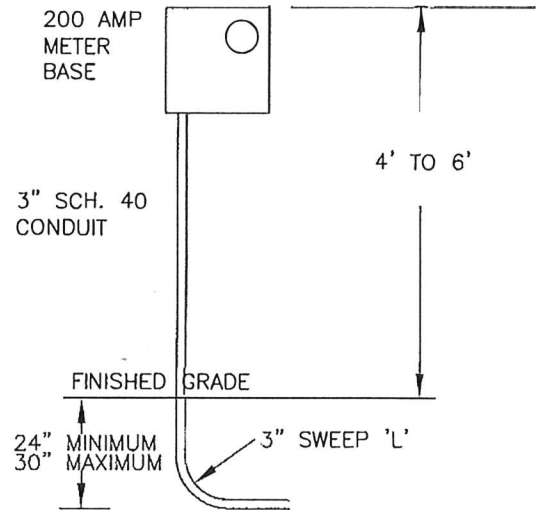
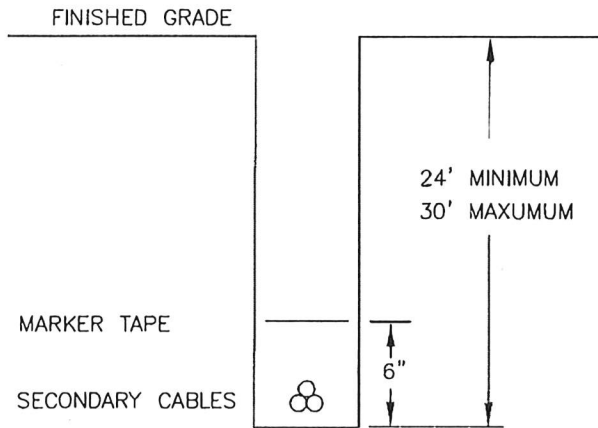

NOTE:

- 1.) TRENCH TO BE FREE OF ROCKS AND ROOTS
- 2.) SELECT BACKFILL TO BE USED TO FILL TRENCH. IF SOIL IS ROCKY, CUSTOMER IS RESPONSIBLE FOR PROVIDING ROCK FREE BACKFILL.
- 3.) BACKFILL TO BE TAMPED TO PREVENT WASHING AND SETTLING
- 4.) MAINTAIN 12' MINIMUM SEPARATION WHEN CROSSING OVER OR UNDER WATER AND SEWER LINES.
- 5.) SECONDARY CABLES ARE NOT TO BE ENERGIZED BEFORE TRENCH IS BACKFILLED TO FINISHED GRADE.
- 5.) METER BASE TO BE INSTALLED ON OUTSIDE EXPOSED WALL BEFORE TRENCHING. DISCONNECTS & OTHER ASSOCIATED EQUIPMENT SHALL BE INSTALLED ON RIGHT SIDE OF METER BASE ONLY.

## SECONDARY TRENCH DETAIL & METER BASE INSTALLATION

NOT TO SCALE: 06-17-22 JHW

TO SCHEDULE TRENCHING

CALL- RANDY FOX \_\_\_\_\_

AT- 227-3203 \_\_\_\_\_

SPECIAL WORK REQUEST/AGREEMENT

The undersigned Applicant and the University agree to the following terms and conditions for the performance of special utility services:

1. Name of applicant: \_\_\_\_\_  
(Corporate name if incorporated)

2. Address and phone number of applicant: \_\_\_\_\_  
\_\_\_\_\_

3. Description of work to be performed: \_\_\_\_\_  
\_\_\_\_\_  
\_\_\_\_\_

(If additional space is needed, attach additional pages  
and initial here \_\_\_\_\_)

4. Estimated price for work (including deposit):  
\$ \_\_\_\_\_

5. Deposit required: \$ \_\_\_\_\_

6. Estimated Date(s) work to be performed: \_\_\_\_\_

7. Applicant's official job site representative with authority to make decisions on the  
job site:

\_\_\_\_\_

8. Additional agreement provisions: \_\_\_\_\_  
\_\_\_\_\_  
\_\_\_\_\_

9. It is understood the Applicant will pay the actual price for the work, as  
determined by the University after completing the work, whether that actual price  
is less than or greater than the estimated price contained herein.

10. It is understood that the University shall perform the work described herein as an  
independent contractor and no partnership, joint venture or employer/employee  
relationship has been created.

11. Applicant warrants that the University will not be infringing on the property right or any other right of any third party by performing the work described herein. Applicant agrees to indemnify and to hold the University harmless from any claim, suit or proceeding arising out of the subject matter of this Agreement, including to indemnify the University for reasonable expenses in defending such claims.
12. This Agreement may not be assigned by Applicant without the express written consent of the University.
13. This Agreement (and its attachments, if any) constitutes the entire understanding between the parties with respect to the subject matter hereof and supersedes any and all prior understandings and agreements, oral and written, relating hereto.

APPLICANT: \_\_\_\_\_

Western Carolina University

By: \_\_\_\_\_

By: \_\_\_\_\_

Address: \_\_\_\_\_

Address: \_\_\_\_\_

\_\_\_\_\_

\_\_\_\_\_

Phone: \_\_\_\_\_

Phone: \_\_\_\_\_

Date: \_\_\_\_\_

Date: \_\_\_\_\_