

FOR LEASE

315-319 W North Ave, Chicago, IL

@properties[®]
COMMERCIAL



SOMETHING NEW IN OLD TOWN

With high household income, strong residential density, and exceptional transportation, Chicago's Old Town neighborhood offers one of the most vibrant neighborhoods in Chicago. Anchored by new high-rise developments to the South and West, Old Town boasts a population of 73,402 within 1 mile with an average household income of \$161,896.

The main East/West corridors is North Avenue, beginning at the Apple Store on North & Clybourne and continuing East until terminating at bustling North Avenue Beach. The primary North/South corridor is Wells, home to boutique stores, local restaurants, vibrant entertainment like Zanies and Second City; and so much more not to mention a new ground up hotel currently under development.

PROPERTY HIGHLIGHTS

- Space 1 measures **1,482 SF**, with great window line along North Avenue.
- Space 2 measures **983 SF**, with equally impressive window line on North.
- Combine the spaces for **2,465 SF** of
- Restaurant infrastructure in place that could service either space.
- Reserved parking in the rear of the building could be made available. Plenty of street parking along North Avenue and in the neighborhood.

TIM RYAN

mobile: 312.217.1591

timr@atproperties.com

GRAHAM MITCHELL

mobile: 312.925.8042

gmitchell@atproperties.com

 atpropertiescommercial.com

All information furnished is from sources deemed reliable. No representation is made as to the accuracy thereof and it is submitted subject to errors, omissions, changes, or withdrawal without notice.

@properties[®]
COMMERCIAL

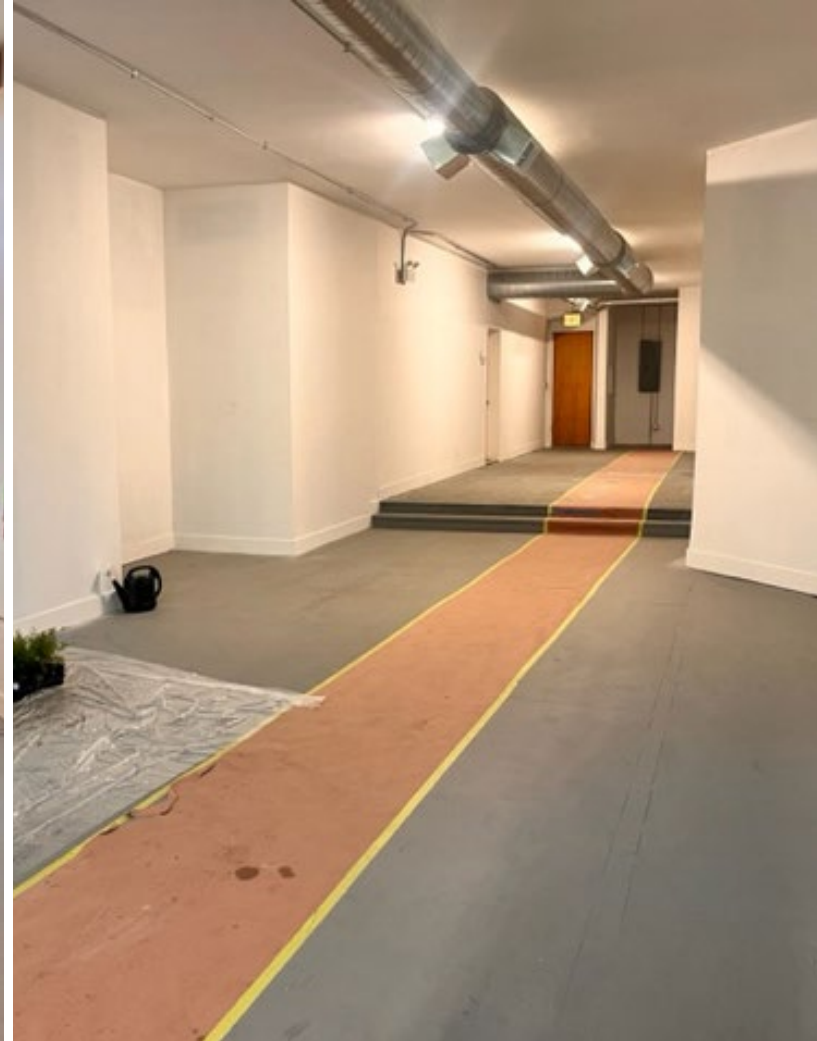

315 floor plan

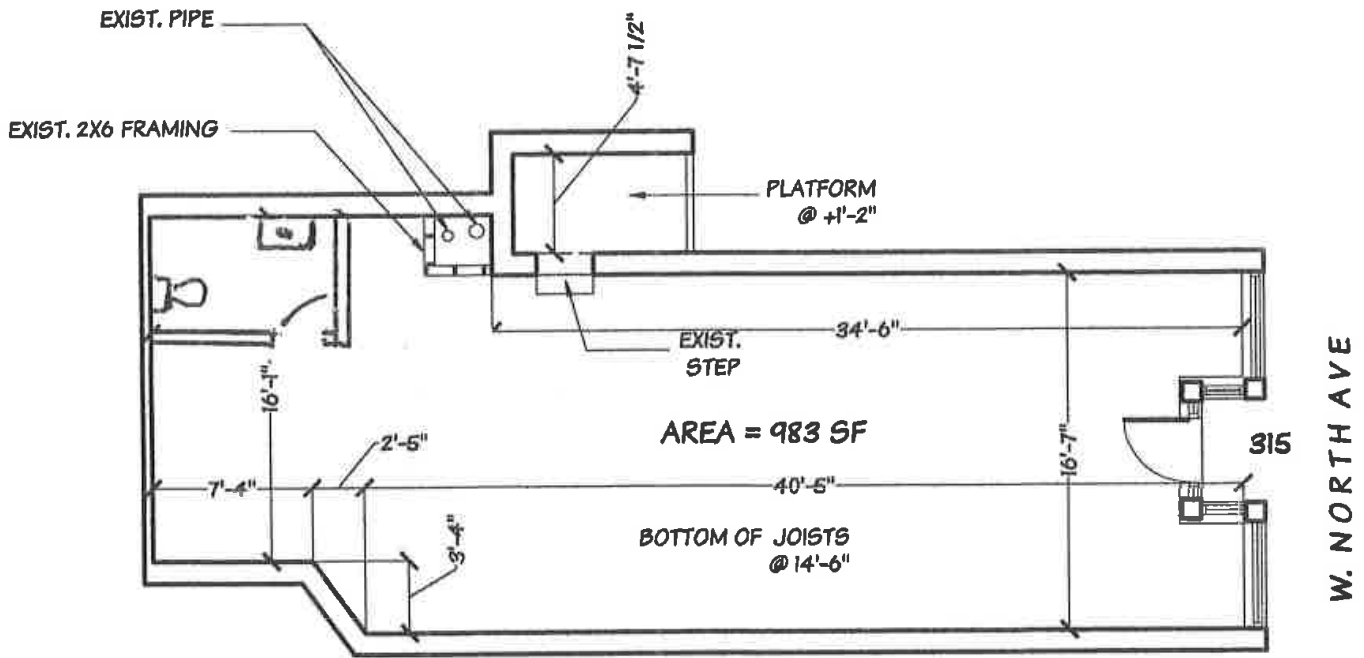

317 floor plan

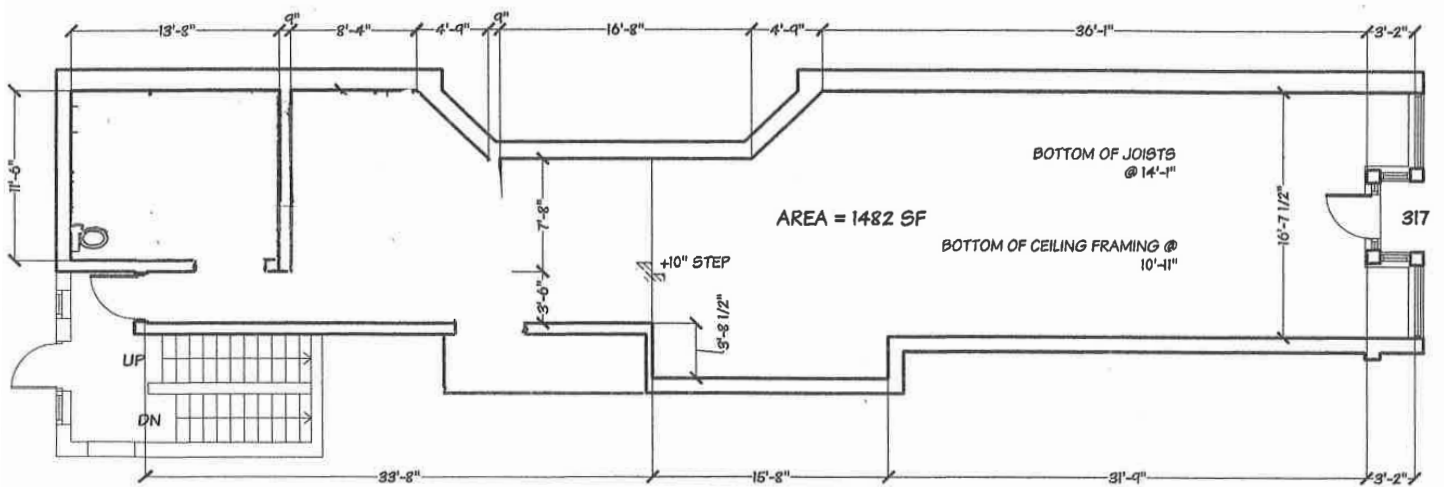

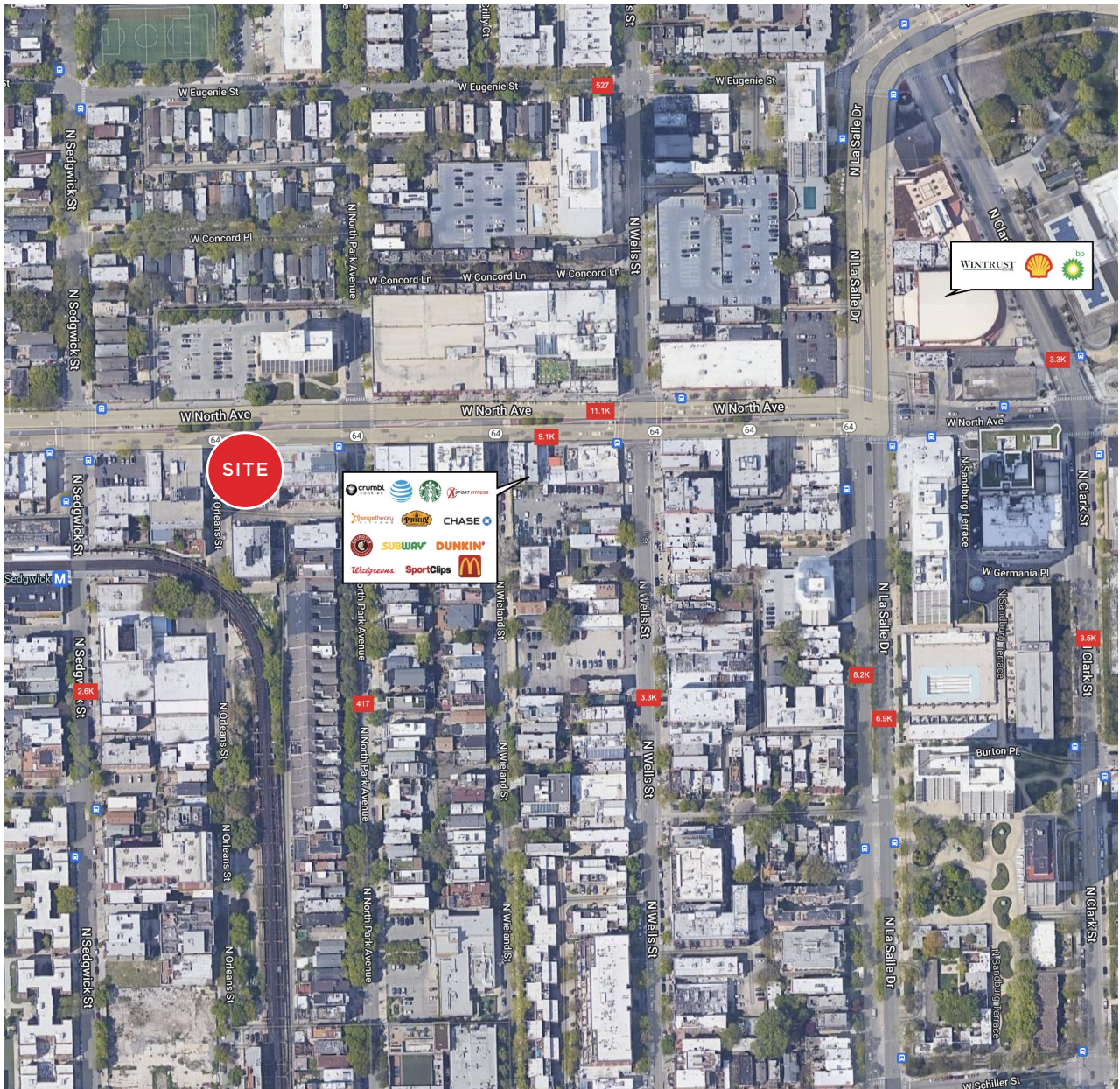

retail and traffic information

Old Town is too hip to ever get old. Located between Lincoln Park and the Gold Coast, the neighborhood continues to capture the interest of homebuyers with its diverse collection of restaurants, shops, and entertainment venues. The upscale neighborhood includes some of the city’s best-preserved historic homes, single-family homes priced well over \$1 million, and many newer condominiums. As the community has edged west in recent years, new development is bringing moderately-priced housing to the area.



demographics

	1 mile	3 mile	5 mile
2023 Estimated Population	73,402	415,837	872,508
2023 Estimated Households	46,082	247,372	447,783
2023 Estimated Average Household Income	\$199,763	\$193,499	\$161,896



TIM RYAN

mobile: 312.217.1591
timr@atproperties.com

GRAHAM MITCHELL

mobile: 312.925.8042
gmitchell@atproperties.com