



INCOME PRODUCING INDUSTRIAL / FLEX BUILDING FOR SALE OR LEASE

(856) 985-9522 • ROSECOMMERCIAL.COM

612 GRAVELLY HOLLOW ROAD, MEDFORD, NJ



Property Description:	Warehouse and office space for Sale or Lease
Building Size:	16,542 +/- SF
Available :	7,000 +/- SF (Divisible)
Zoning:	Planned Industrial (PI)
Taxes:	\$23,444.99
Sale Price:	\$1,900,000.00 \$1,650,000.00
Lease Rate:	\$10.00/ SF NNN

- Comments:**
- Recently renovated warehouse/ flex building
 - Ideal for owner user or investor
 - New windows, doors, HVAC, and roof throughout
 - Ceiling heights range from 10' - 15'
 - 2 loading door and 6 drive in doors
 - Ample parking

Michelle Marinello (Ext. 28)
mmarinello@rosecommercial.com
(856) 985-9522

Rose Commercial Real Estate is a full service commercial real estate firm, specializing in all facets of the industry ~ representing buyers and sellers, landlords and tenants as well as investors both big and small. Key to our growth is experience combined with in depth understanding of the South Jersey real estate market. But that alone is only a part of the comprehensive service we provide clients. With our unique **CIRCLES FOR SUCCESS** and start-to-finish commitment, we make things happen.

651 Route 73 North, Suite 111 • Marlton, NJ 08053 • Phone: (856) 985-9522 • Fax: (856) 985-9488

ROSECOMMERCIAL.COM



INCOME PRODUCING INDUSTRIAL / FLEX BUILDING FOR SALE OR LEASE

(856) 985-9522 • ROSECOMMERCIAL.COM

612 GRAVELLY HOLLOW ROAD, MEDFORD, NJ

BUILDING FLOOR PLAN

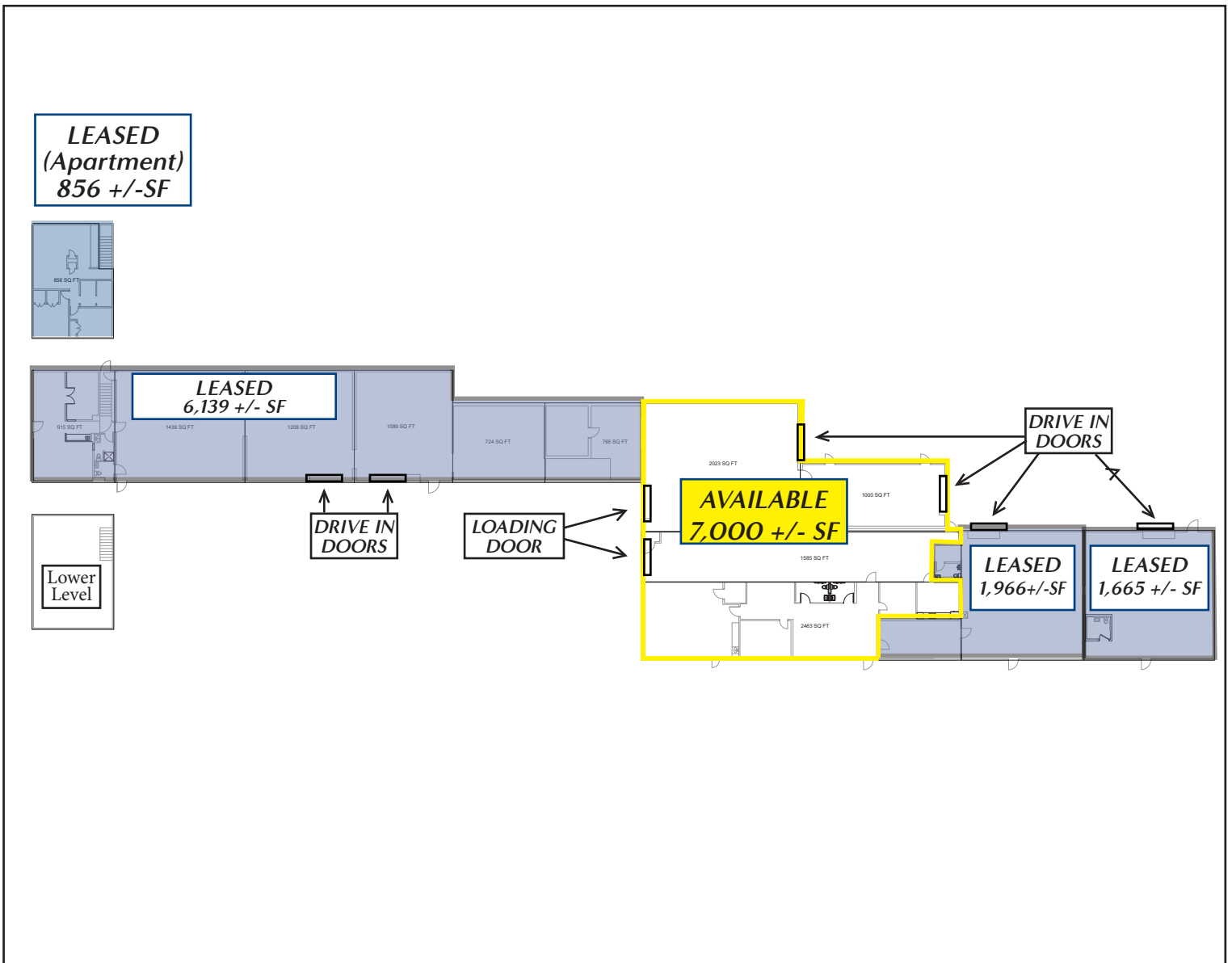



INCOME PRODUCING INDUSTRIAL / FLEX BUILDING FOR SALE OR LEASE

(856) 985-9522 • ROSECOMMERCIAL.COM



651 Route 73 North, Suite 111 • Marlton, NJ 08053 • Phone: (856) 985-9522 • Fax: (856) 985-9488

ROSECOMMERCIAL.COM



INCOME PRODUCING INDUSTRIAL / FLEX BUILDING FOR SALE OR LEASE

(856) 985-9522 • ROSECOMMERCIAL.COM

612 GRAVELLY HOLLOW ROAD, MEDFORD, NJ

7,000+/- SF AVAILABLE - SUITE E/F

