



City of Hackensack

Redevelopment Plan

for the Main Street Area in Need of Rehabilitation

Volume 1

Amendments: January 2025

City of Hackensack
Redevelopment Plan
for the Main Street Area in Need of Rehabilitation

Prepared by DMR Architects

ACKNOWLEDGEMENTS

Mayor and Council

Mayor John P. Labrosse
 Deputy Mayor Kathleen Canestrino
 Councilman Leonardo Battaglia
 Councilwoman Stephanie Von Rudenburg
 Councilman Gerard L. Carroll

Planning Board

Fernando Garip, Jr. - Chairman
 John Chiusolo - Vice Chairman
 John P. Labrosse - Mayor
 Kathleen Canestrino - Deputy Mayor
 Albert Dib - Member
 Michael Allegretta - Member
 Ralph Contini - Member
 Joseph Martucci - Member
 Kimberly Solomon – Member
 Press Iyamu – Alternate

Planning Board Attorney

Joseph L. Mecca, Jr., Esq.

Planning Board Engineer

Gregory J. Polyniak, P.E., P.P., C.M.E., Neglia Engineering

Redevelopment Consultant / Professional Planner

Mr. Francis Reiner, PP - LLA - DMR Architects

Redevelopment Attorney

Mr. Brian Nelson, Esq. - Archer Greiner, P.C.

Chief Financial Officer

Mr. James Mangin

City Manager

Mr. Vincent Caruso, MAS

Special Thanks

The City of Hackensack would like to thank the Upper Main Alliance Special Improvement District (SID) and its members for their continuing efforts in supporting the revitalization of the downtown district. Through the SID's Main Street Initiative, the efforts of its consultant Street-Works, and the extensive public input that was received during the Street-Works led workshops, the City has developed this Redevelopment Plan as a tool to promote the creation of a livable and dynamic downtown district which will become the social, cultural and economic heart of the community.

Specifically, the City would like to thank Jerry Lombardo, Chairman of the Upper Main Alliance, and its Board of Directors for their tireless advocacy in support of revitalizing the downtown district, as well as for their foresight in hiring Street-Works to undertake the Main Street initiative in order to determine ways to make our community a better place. Led by its partners Ken Narva, Lucy Wildrick, Tim Mount and Gregg Sanzari, Street-Works' expertise and knowledge of urban development and revitalization have been invaluable to this process.

Additionally, the City would like to thank the hundreds of members of the community who participated in the Street-Works led workshops. Many of the ideas, plans, and images discussed at these workshops and presented by Street-Works have been incorporated into this planning document which will benefit the City and its residents for years to come.

Table of Contents

Volume 1:

Page

1. Introduction:

1.0: Background Information:1-1
 1.1: Rehabilitation Area Boundary / Description :1-2
 1.2: Vision Statement:1-3
 1.3: Planning Goals and Purpose:1-4

2. Land Use & Zoning:

2.0: Definitions:2-1
 2.1: Permitted Principal Uses:2-3
 2.2: Conditional Uses:2-4
 2.3: Accessory Uses:2-4
 2.4: Prohibited Uses:2-5
 2.5: Bulk Standards:2-6
 2.6: Parking Standards:2-8
 2.7: Screening Standards:2-12

3. Design Standards:

3.0: Development / Place-Making Design Standards:3-1
 3.1: Rehabilitation Standards:3-9
 3.2: Streetscape Design Standards:.....3-11
 3.3: Signage Standards:3-17

4. Circulation Plan:

4.0: Circulation Overview: 4-1
 4.1: Conceptual Street Sections: 4-4

5. Implementation Strategies:

5.0: Implementation Strategies5-1
 5.1: Rehabilitation Process.....5-1
 5.2: Financing / Funding Mechanisms.....5-2
 5.3: Implementation of Redevelopment Plan.....5-3
 5.4: Phasing.....5-3
 5.5: Selection of One or More Redevelopers.....5-4
 5.6: Negotiation of One or More Redevelopers.....5-4
 5.7: Pre-application Review Committee Process and Requirements.....5-4
 5.8 Additional Submission Requirements.....5-5
 5.9 Affordable Housing.....5-5

6. Appendix:

6.0: Relationship of Redevelopment Plan to Master Plans.....6-1

1

Introduction

1.0 Background Information:

1. On March 1st, 2011, the Hackensack City Council adopted Resolution No. 112-11, which authorized an investigation into whether or not the city blocks and lots listed and marked in cross-hatch on the map entitled “Exhibit ‘A’ - Area in Need of Rehabilitation, City of Hackensack – New Jersey Delineation Map Study Area”, prepared by DMR Architects, dated January 18th, 2011, constitute an area in need of rehabilitation. This includes the portions of the following rights-of-way that border upon and/or bind together the cross-hatched city blocks and lots: Bergen County Place, Essex Street, State Street, New York Susquehanna / Western Railway, Union Street, Central Avenue, State Street, Ward Street, Union Street, Anderson Street, Pangborn Place, Clinton Place, Main Street, University Plaza Drive and River Street (hereinafter the “Study Area”).
2. On April 18th, 2011, DMR produced a report entitled “Area in Need of Rehabilitation Study” that supported a finding that the Study Area qualified as an area in need of rehabilitation because a majority of the storm water and sanitary sewer infrastructure in the delineated area is at least 50 years old and is in need of repair or substantial maintenance. A program of rehabilitation as defined in N.J.S.A. 40A:12A-3 may be expected to prevent further deterioration and promote the overall development of the community.
3. On June 8th, 2011, the Planning Board issued its recommendation that the Study Area be designated an area in need of rehabilitation.
4. On June 21st, 2011, the City Council adopted Resolution No. 208-11 which;
 - 1) accepted the recommendation of the Planning Board;
 - 2) adopted the findings of the area in need of rehabilitation study prepared by DMR; and
 - 3) declared that the Study Area constitutes an area in need of rehabilitation because the majority of the storm water and sanitary sewer infrastructure in the Study Area is at least 50 years old and is in need of repair or substantial maintenance and a program of rehabilitation as defined in N.J.S.A. 40A:12A-3 may be expected to prevent further deterioration and promote the overall development of the community;
5. The City Council directed that the City Manager and City Attorney supervise the undertaking of a planning, engineering and legal analysis to develop a program of rehabilitation for the Main Street rehabilitation area including the preparation of a redevelopment plan. The Plan was adopted on June 27, 2012.
6. On April 9th, 2013, the governing body referred proposed amendments to the original Redevelopment Plan to the Planning Board and on June 10th, 2013, the governing body adopted Ordinance No. 15-2013 adopting the first set of amendments to the Redevelopment Plan.
7. On May 20th, 2014, additional amendments which include unit size and yield as well as parking and other technical changes were adopted by the governing body as stated in Ordinance 21-2014.
8. On October 20th, 2015, additional amendments which established more specific zoning and design standards governing building heights, set-backs, permitted uses, disallowing drive thrus, parking, building materials, utilization of sidewalks, and streetscapes.
9. On July 23rd, 2018, additional amendments which establish more specific zoning and design standards governing streetscape design, shared parking, permitted uses, and other bulk standards.
10. On January 8th, 2019, additional amendments which establish additional parking standards for adaptive reuse of pre-existing buildings, standards for temporary signage, and other bulk standard adjustments.
11. On June 15, 2021, additional amendments were adopted which established conditional uses, new parking standards for electric vehicle spaces, updated terminology, updated affordable housing requirements, and eliminated outdated project financing language.

1.1 Rehabilitation Area Description:

1. The Rehabilitation Area consists of approximately 163.80 acres on 389 parcels in 39 city blocks which are depicted on Figure 1.0 and Figure 1.1. These city blocks contain ten (10) separate land use classifications including: High Density and Medium Density Residential, Commercial, Office, Semi-Public, City, County, Parks and Recreation, Redevelopment Office and Parking.
2. The street boundaries of the Rehabilitation Area are Bergen County Place, Essex Street, State Street, New York Susquehanna / Western Railway, Union Street, Central Avenue, State Street, Ward Street, Union Street, Anderson Street, Pangborn Place, Clinton Place, Main Street, University Plaza Drive and River Street.
3. A complete breakdown of the parcels in the Rehabilitation Area is provided in the Appendix and includes a table identifying each parcel, with the tax block, lot and street address. This information is based on the Bergen County GIS Tax Parcel Online Database.
4. Based on information provided in the City of Hackensack 2001 Master Plan and the City of Hackensack Master Plan Reexamination Report dated July 8th, 2009, the existing land uses in the Rehabilitation Area consist of the following:
 1. Office (52.18%).....203 parcels;
 2. General Commercial (34.96%).....136 parcels;
 3. High Density Res./Commercial (6.42%).....25 parcels;
 4. Parking (2.05%).....8 parcels;
 5. City (1.28%).....5 parcels;
 6. Semi-Public (1.02%).....4 parcels;
 7. Parks & Open Space (1.02%).....3 parcels;
 8. Medium Density Residential (0.51%).....2 parcels;
 9. County (0.51%).....2 parcels;
 10. Redevelopment Office (0.25%).....1 parcel;

Block Numbers - Area in Need of Rehabilitation

The Area In Need of Rehabilitation Area consists of the following Blocks as they are shown on the Tax Map for the City of Hackensack

Block 310	Block 406	Block 205
Block 311	Block 407	Block 206.01
Block 311.01	Block 407.01	Block 206.02
Block 312	Block 408	Block 207
Block 313	Block 409	Block 208
Block 314	Block 410	Block 209
Block 315	Block 411	Block 210.01
Block 316	Block 64	Block 210.02
Block 401	Block 200	Block 301
Block 401.01	Block 202	Block 302
Block 402	Block 203	Block 303
Block 403	Block 204	Block 304
Block 405	Block 204.01	Block 309

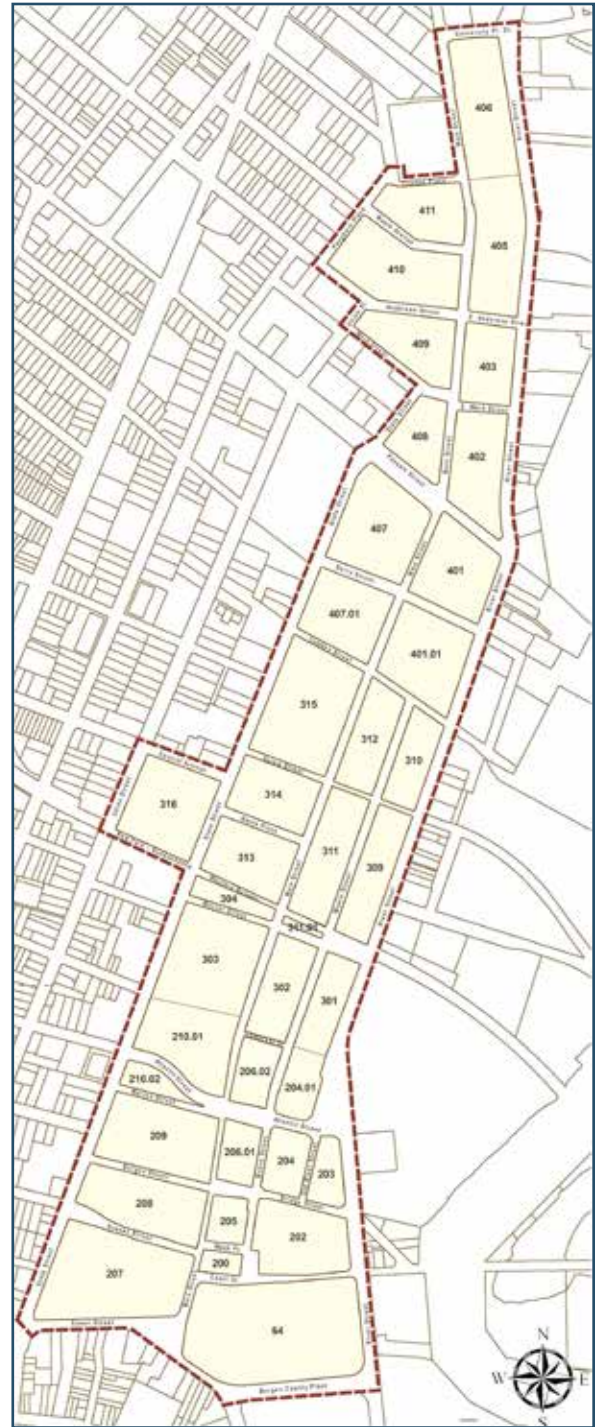

Figure 1.1: Designated Area in Need of Rehabilitation Boundary and Block Number Map

1.2 Vision Statement:

“The vision for this Redevelopment Plan for the Main Street Rehabilitation Area (hereinafter “Redevelopment Plan”) is to promote the creation of a livable and real downtown district with clear boundaries and gateways, which strengthen existing businesses and provides opportunities for new mixed use development which will become the social, cultural and economic heart of the City of Hackensack and Bergen County through the design and development of an immersive, authentic, place-based urban environment.

The plan promotes a diversity of land uses, businesses and housing types with high quality architecture designed from the street up which includes improved infrastructure, streetscape and a hierarchy of parks and open spaces to support a business friendly atmosphere with a diverse population of varied ages, races and socio-economic backgrounds.”



Figure 1.2: Conceptual Streetscape Perspective



Figure 1.3: Conceptual Redevelopment Plan

1.3 Planning Goals / Purpose:

1. To promote and strengthen existing businesses with the creation of a livable, real and clearly defined downtown district, made up of a series of interconnected, newly formed, mixed-use neighborhoods which are connected to their immediate context;
2. To promote and encourage existing property owners to undertake the rehabilitation of their property within the Rehabilitation Area.
3. To promote the development of a place-based environment where people live and work, connected by great streets and activated by appropriate retail, food and entertainment uses;
4. To promote an environment that fosters the development of cultural, educational and civic facilities and uses which enrich the lives and experiences of city and county residents;
5. To promote the preservation, adaptive reuse and integration of historic and architecturally significant buildings within the Rehabilitation Area in order to maintain and promote the rich history of the city and the downtown;
6. To promote a balance between pedestrian and vehicular importance through the design of a hierarchy of streets, roads, gateways and boundaries which promotes activity and vitality;
7. To promote a series of memorable public places and spaces connected by great sidewalks and streetscape elements, enhanced by public art, safe lighting and on-street parallel parking, that promote outdoor dining, walking, people watching and gathering, activated by a clearly organized program of street retail and restaurants;
8. To promote improved pedestrian and vehicular connectivity into and through the downtown and to adjacent existing residential and commercial neighborhoods as well as to transportation and transit options;
9. To promote an overall approach to downtown parking based on a shared vertical parking strategy reflective of a mixed use environment which emphasizes quality, accessibility, location, size, scale, configuration, management and aesthetic character over quantity;
10. To promote and take advantage of the physical relationship of the downtown to the County Complex, Bergen Community College, Fairleigh Dickinson University and Hackensack University Medical Center;
11. To promote the development of a compact urban environment with improved connectivity to the existing rail and bus transit in order to encourage walking and minimize vehicular dependency;
12. To promote and improve the efficiency and capacity of the existing street network to better accommodate vehicles, pedestrians and bicycles in the context of a complete street;
13. To promote a high density, mixed use development with a diverse residential population of varied ages, races and socio-economic backgrounds;
14. To promote a clear, understandable and streamlined business friendly process for the review and approval of new development while promoting and strengthening existing businesses;
15. To promote flexibility within the plan to adapt to changing economic and political environments;
16. To promote the revitalization of the downtown area by focusing on the development of three primary mixed use “catalyst” areas within the newly defined Rehabilitation Area with opportunities for residential, office, cultural and civic uses that are activated by a two-sided retail street experience; and
17. To promote the principles of sustainable design for individual buildings and for the district as a whole.

2

Land Use & Zoning

2.0 DEFINITIONS:

It is the intention of this Redevelopment Plan for the Main Street Rehabilitation Area supersede existing zoning (except as noted herein) as provided under the Local Redevelopment and Housing Law, N.J.S.A 40A:12A-1, et seq. However, this plan adopts the definitions of the City's Land Use Ordinance Section 175-2.2 by reference.

The definitions of the City's Land Use Ordinance shall apply to this plan, unless this plan provides a superseding definition. The definitions defined in Section 175-2.2 apply to the Rehabilitation Area with the exception of the following terms:

ADULT ENTERTAINMENT: A business in which, as the major activity, customers congregate primarily for the purpose of viewing or associating with employees who display anatomical areas designed to provide sexual stimulation or sexual gratification.

BASIC RESEARCH: Research activities which do not involve the storage, use, or manipulation of hazardous materials in excess of that typical of any other permitted commercial use; and where noise, vibration, heat, radiation, and environmental emissions are not detectable beyond the enclosed space in which these activities take place or beyond the property lines where the research establishment is the only use on the property.

BUILDING BASE: The building base refers to the first three levels of a particular building.

BUILDING FACADE: The exterior portion of a building exposed to public view.

BUILDING HEIGHT: The vertical distance of a building measured from the average of the top of curb of the two corners of the proposed building to the highest roof beams of a flat roof. For projects located at a corner lot, the height will be measured from the top of curb of the two corners located along the primary building facade. For project that have a grade change an additional level of parking may be provided at the lower grade of the property.

BUILDING PROPORTION: The width to height relationship of one building to another.

BUILDING FRONT YARD SETBACK: The distance measured from the back of existing or proposed curb (whichever is greater) to the primary building facade.

COVERAGE, BUILDING: As defined at §175-2.2 except that porches, decks, terraces, and patios, and permanent projections and overhangs of more than two feet from the building wall such as canopies and permanent awnings are exempt from building coverage.

FENCE: An artificial barrier constructed of durable materials including brick, stone, other masonry material, wood posts and planks, metal or other materials designed for fencing with a maximum height of four feet. (A chain link fence of any type does not satisfy the definition of a fence)

INDOOR AMUSEMENT & RECREATION: Establishments providing and maintaining indoor facilities where the public may engage in or enjoy amusement or recreational activities, such as dance halls; studios; bowling alleys; commercial facilities such as arenas, rings, and rinks; go-carting; indoor driving ranges or miniature golf; archery; sports and health clubs; arcades; expositions; swimming pools; tennis courts; and other athletic, performance, and recreational activities that may be safely enjoyed within a building.

GENERAL OFFICE: Business offices, and offices for State-licensed professionals and professional firms except for medical offices.

LIVE ENTERTAINMENT: Establishments or accessory uses which provide live entertainment consisting of vocalist, instrumental music or dancers, and, for the purpose of this Plan, spoken word, theatrical performance, comedy, or similar entertainment where patrons are entertained typically for a fee, whether such fee shall be direct or indirect through a charge for other products or services, but not including halls, auditoriums, or religious, civic or fraternal

organizations.

MAKER SPACE (WORK SHARE): A maker space is a community space or other gathering place where individuals are able to take part in a collaborative hands-on process which provide opportunities to design, create, manufacture, and invent new things.

MEDICAL OFFICE: An establishment from which a licensed medical professional and their staff provide outpatient medical services including check-ups, diagnosis, consultation, treatment, and other services that are customarily and typically provided in doctors and dentists offices. Medical offices shall not include hospitals, nursing homes, convalescent homes, rehabilitation centers, or in-patient medical services involving overnight stays, nor shall they include establishments providing group-based counseling for substance abuse or addiction. For the purposes of this Plan, Medical Office shall include physical therapy and basic research.

MULTI-FAMILY: Housing accommodations that are designed principally for residential use, conform to standards satisfactory to the Secretary of Housing and Urban Development, and consist of not less than five (5) units on 1 site. These units may be detached, semidetached, row house, or multifamily structures.

NIGHTCLUB or DANCE CLUB: An establishment that is only open in the evenings and at night, in which music is provided, along with space in which dancing may be conducted, and where alcohol may be served to patrons ages 21 and older.

PEDESTRIAN SCALE: The relationship of a particular building, in terms of mass and scale to a pedestrian.

PHYSICAL THERAPY: An establishment in which one or more licensed physical therapists and their staff provide physical therapy services as licensed and regulated by the State to clients for purposes including post-surgical rehabilitation, pain reduction, and other common purposes for such services.

POP-OUT / PROTRUSION: A portion of the primary building facade that projects into the building setback.

REDEVELOPER: Any person, firm, corporation or public entity that is seeking any financial incentives shall be designated as a Redeveloper by the City Council or Redevelopment Entity and shall enter into a Redevelopment Agreement as set forth in Section 5 of this Redevelopment Plan, all in accordance with the Local Redevelopment and Housing Law, N.J.S.A. 40A:12A-1 et seq.

RESIDENTIAL MICRO-UNIT: A residential unit less than 550 gsf.

RESTAURANT: A building or structure designed, used or intended for use in which food and beverages are sold and consumed.

STREET FURNITURE: The elements of streetscape, including but not limited to benches, bollards, news-racks, trash receptacles, tree grates, hardscape, seat-walls, street lights, and street trees.

SMOKE SHOP: A retailer meeting the definition of a tobacco retail establishment at N.J.S.A. 26:3D-57, and where at least 51 percent of sales are of tobacco products and accessories and where the sale of any other products is incidental to the business of selling tobacco products and accessories.

TANDEM PARKING: Two parking spaces with one car in front of the other to be allocated to a single apartment.

TATTOO PARLOR: An establishment in which tattooing is carried out professionally (Requires a New Jersey Department of Health License)

VISUAL COMPATIBILITY: The design of buildings which is consistent in scale and character with adjacent buildings in the area from a pedestrian perspective in which the design is consistent with the architectural and neighborhood design standards set forth in this document.

2.1 Permitted Principal Uses:

1. The following uses are permitted **principal uses** in the Redevelopment Plan, except as otherwise provided herein:
 - a. **Residential:** Multi-family residential (apartments or condominiums) are permitted above “Mixed Use Eligible” uses listed in subsection “b”;
 - b. **Mixed Use Eligible:** The following uses are permitted to be mixed with residential uses or with each other in a single building or complex:
 - i. **Commercial/Retail:**
 - General office,
 - Health clubs & day spas, -
 - Banks,
 - Hotel,
 - Live Entertainment,
 - Art gallery,
 - Indoor amusement and recreation,
 - Dance clubs and night clubs, subject to all applicable City and State regulations,
 - Eating and drinking establishments,-
 - Movie theater,
 - Grocery store / supermarket,
 - Personal services
 - ii. **Civic, Cultural, Institutional:**
 - Recreation centers,
 - Athletic and sports facilities,
 - Libraries,
 - Museums,
 - Police and fire stations;
 - iii. **Education:**
 - Primary Through Secondary Education: Public/private elementary, junior and senior high schools, and child day-care
 - Higher Education: Colleges, universities, trade schools, adult training facilities, dormitories;
 - iv. **Transit Stations:** Including parking facilities, “Park and Ride” and “Kiss and Ride”;
 - v. **Structured Parking:** Principal and/or accessory use;
 - vi. **Maker Space/Work Share**
 - c. **Stand Alone Uses:** The following uses are permitted alone, and not permitted in the same building as any other use.
 - i. **Utility and Related Facilities:** Such as distribution lines, railroad rights-of-way, telephone repeater stations, and water storage tanks. (These uses are not permitted to front Main Street);
2. **Omission of Use:** Any use not stated as a Permitted Use is not allowed in the Rehabilitation Area;
3. **Relation to Structured Parking:** The uses listed above are permitted in the stories above structured or sheltered parking areas integrated into the building, or as “liner” uses separating the parking areas from the street or from any property boundaries.
4. **Ground Level Uses on Main Street and Banta Place:** Residential lobbies and entrances for the residential portion



Figure 2.1: Rehabilitation Area Permitted Uses

of a mixed-use building, however, are permitted on the first floor on Main Street and should be distinct and separate from the entrances of all other first floor uses;

- Lobbies and entrances shall not exceed 35% of the frontage of any building on Main Street;

5. Existing nonconforming uses or structures are permitted to continue as per N.J.S.A. 40:55D-68. However, the renovation or restoration of a nonconforming use or structure shall be accomplished as per the Rehabilitation Standards of this Plan;

2.2 Conditional Uses:

1. The following are permitted conditional uses in the Rehabilitation Area, subject to the conditions listed.
 - a. Tattoo Parlors:
 - i. The establishment has a state permit and individuals performing the services have a State Department of Health License.
 - ii. No establishment can be located within 1,500 feet of another similar facility.
 - iii. The establishment requires appointments only.
 - iv. Walk-ins are not permitted.
 - b. Beauty Service:
 - i. No establishment shall be within 400 feet of a similar existing establishment.
 - c. Medical Office:
 - i. Shall not exceed the greater of 6,000 square feet or 20% of leasable non-residential space.
 - ii. Shall not be located above the second story of any building.
 - d. Live-Work Studios: For artists, designers, photographers, musicians, sculptors, gymnasts, potters, wood and leather craftsmen, glass blowers, weavers, silversmiths, antique dealers and designers of ornamental and precious jewelry, and meeting the definition in §175-2.2 of the City Zoning Ordinance:
 - i. Subject to the conditional use standards at §175-8.2.C.13 of the City Zoning Ordinance
 - e. Smoke Shops:
 - i. No such establishment shall be within 1,000 feet of a similar existing establishment;
 - ii. Shall not sell flavored vapor tobacco product.
 - f. General and Neighborhood Retail
 - i. Shall not include more than ten percent (10%) of floor area space for the sale of tobacco products, hookahs, electronic vapor devices, electronic inhalation substances or drug paraphernalia to purchasers for consumption or use;

2.3 Accessory Uses:

1. Accessory uses and structures shall be permitted which are clearly and customarily incidental and subordinate to a permitted or conditional principal use on the same property. Examples of permitted accessory uses include, but are not limited to, the following:
 - a. Hotels & Office Buildings:
 - i. Shops, services, conference rooms, meeting areas, ATMs, vending machines, massage therapy, and other services which are accessible only to guests, employees, and tenants, provided they are located on first or second stories.
 - b. Eating and Drinking Establishments
 - i. Outdoor beer gardens and patios, as well as temporary canopies, umbrellas, or other weather shelter for such spaces;
 - ii. Rooftop dining and service areas, including rooftop bars;
2. Accessory structures shall comply in all respects with the setback, building/impervious coverage, and height requirements of this Redevelopment Plan applicable to the principal structure, with the following exceptions.

- a. No accessory structure shall be located closer to the street right-of-way line than the principal structure;
 - b. The aggregate area covered by accessory structures shall not exceed twenty-five percent (25%) of the rear yard (less required buffer areas), with the exception of parking structures and outdoor patios.
 - c. Accessory structures below grade shall have a minimum rear or side yard, when not abutting a street, of five feet;
 - d. No permitted accessory use or structure may occupy or prevent proper usage of any off-street or on-street parking spaces except as may be temporarily permitted by the City for special events or purposes.
3. No accessory structure shall be constructed or placed on any lot unless the principal structure is first constructed or placed upon said lot, with the exception of parking facilities (surface or structure) which may be constructed prior to the primary use.
 4. In no event shall the height of an accessory structure exceed the height of the principal building except for parking structures.
 5. Except for structured or sheltered parking areas wrapped or below multi-family residential uses, no portion of an accessory structure shall include living quarters;
 6. **Other Accessory Uses:** The following standards shall apply to the below listed accessory uses
 - a. **Live Entertainment Uses:** Live entertainment may be provided as an accessory use in any eating or drinking establishment, cafe, civic, cultural, or institutional establishment in accordance with all applicable City codes.
 - b. **Outdoor Open Markets:** Permitted by special permit on City or Board of Education owned properties for selling fresh food and plants based on state laws and regulations.
 - c. **Outdoor Music:** Permitted per the City's Noise and Outdoor Cafe Ordinance.
 - d. **Structured Parking:** Parking areas which are accessory to and either built into or attached to a building or containing permitted principal and conditional uses may be located below or behind those uses in such building provided that they are screened from the public rights-of-way and from adjacent properties in accordance with the requirements of this Redevelopment Plan.



Figure 2.2: 2001 City Master Plan Zoning Classifications Kasler Associates

2.4 Prohibited Uses:

1. Any use not specifically designated as a principal permitted use, an accessory use or a conditional use, and any use explicitly prohibited in Chapter 175 of the City Code is prohibited in the rehabilitation area.

2.5 Bulk Standards:

The following requirements apply for the Redevelopment Area:

1. **Minimum Lot Area:** None
2. **Dwelling Unit Sizes:**
 - a. A maximum of 5% can be less than 550 sf;
 - b. A maximum of 20% can be between 550 sf and 650 sf;
 - c. A maximum of 25% can be over 1,200 sf.
3. **Minimum Setback:** The minimum setback for new buildings or parking structures from the face of the existing or proposed curb shall be as follows:
 - a. Main Street, Essex Street, Passaic Street, River Street State Street and Banta Place - 18'-0" .
 - b. All other streets in the Rehabilitation Area - 12'-0"
 - The minimum setback applies to all public street frontages, not just to the street toward which the structure is oriented;
 - Alleys are not considered public street frontages;
 - Utility structures, exhaust air vents, backflow preventers, or other similar devices when located above grade, must be located behind the setback, be screened and should not be located on Main Street;
 - Utility structures located below grade may be located within the setback and on Main Street;

If the renovation or addition of an existing structure is located within the required setback, the setback for the addition may be reduced to the setback established in Chapter 175.
4. **Minimum Side / Rear Yard:** None
 - a. Except that a setback of 20'-0" shall be required where the rear lot line abuts a one- or two-family dwelling.
5. **Minimum / Maximum Number of Stories/Building Height:**
 - a. Main Street: 2 /6 Stories (24'-0" / 72'-0")
 - Block 405 Lot 3, 14 and Block 406 Lot 1.03 14 stories will be permitted



Figure 2.3: Residential over Retail



Figure 2.4: Residential over Retail

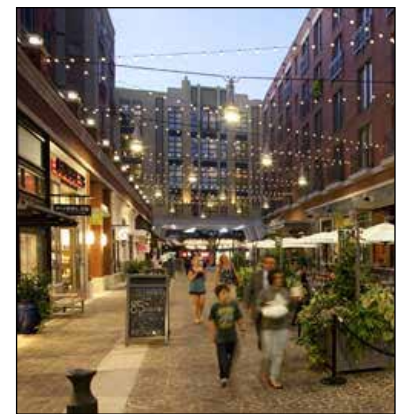

Figure 2.5: Tivoli lights over street



Figure 2.6: Example of potential residential over retail



Figure 2.7: Example of potential Banta Place design

to have a maximum 14 stories and 168 feet in height for new structures based on the previously approved Redevelopment Plan for those properties. (Ordinance No. 54-2021)

- b. Other Properties: 1/6 stories (24'-0" / 72'-0")
 - c. Height is measured from the average of the top of curb of the two corners of the proposed building. For projects located at a corner lot, the height will be measured from the top of curb of the two corners located along the primary building facade;
 - d. Rooftop appurtenances, which include rooftop mounted equipment, elevator shaft equipment and structures, and stairwell structures, may exceed the building height by not more than 12'-0". Rooftop solar panels or telecommunication antennae shall be limited to the heights permitted by §175-11.3.N and §175-14.1 et seq., respectively.
 - e. Parking structure maximum height is 74'-0" measured to the top of the roof level parapet wall, calculated based on a first floor height of 16'-0" for liner uses and subsequent floor to floor heights of 10'-2", excluding the height of stair and elevator towers;
 - f. See Section 3.0 Development / Place-Making Design Standards for all building design requirements;
6. **Maximum Impervious Coverage:** 90% of lot or tract area
- a. Pervious surface and / or storm-water management systems will be required for any proposed development to reduce the impacts to the City's sewer system. Infrastructure improvements would include but not be limited to green roofs, planter boxes and trays, permeable pavers, and above or below grade storm-water management systems.
 - The improvements shall be provided in order to ensure that the post-construction peak runoff rates for the 2 year, 10 year, and 100 year storm events are a maximum of 90 percent of the pre-construction peak runoff rates.
7. **Rehabilitation of Existing Structures:** The density, area, yard and height requirements of this section are not required for rehabilitation of existing structures with less than 20% expansion.
- a. See Section 3.1 Rehabilitation Standards for all Architectural and Neighborhood Design requirements;



Figure 2.8: Example of residential and streetscape

2.6 Parking Standards:

1. **New Construction Parking Ratios:**

The minimum parking requirements for new development projects which meet the Density, Area, Yard and Height Requirements for the Rehabilitation Area are as follows:

<i>Use****</i>	<i>Parking Ratio</i>
- Multi-family:	1.0 sp per studio or efficiency dwelling unit + 10% for guests 1.25 sp per dwelling unit for all other units +10% for guests
- Eating and Drinking Establishments:	8.0 sp/ 1,000 GFA*
- Medical Office:	4.0 sp/1,000 GFA
- General Office:	3.5 sp/1,000 GFA
- Hotel:	0.75 sp/ per room + 1 sp/employee**
- All other Commercial / Retail Uses:	4.0 sp/1,000 GFA*
- Civic, Cultural, Institutional, Assembly and Live Entertainment:	1.0 sp/4.0 seats***
- Higher Education:	3.0 sp/1000 GFA
- Other Education Uses:	See §175-13.1.B.2.

2. **Existing Commercial / Retail / Eating and Drinking Establishment Parking Requirements:**

1. New tenants in existing Commercial / Retail / Eating and Drinking Establishment spaces less than 10,000 sf, do not require parking for customers.
2. Off-site parking for existing Commercial / Retail / Eating and Drinking Establishment spaces is required for the maximum number of employees only during peak hours.
 - a. These parking requirements can be met either on-site or within 800 feet, on either a municipal lot or on a lot owned by the same property owner of the commercial / retail space in question.
 - b. Monthly parking on a municipal lot would need to be available and provided in perpetuity or until the use changes or parking is provided by some other means identified within this redevelopment plan and acceptable to the Planning Board.
2. Parking shall be required for Commercial / Retail / Eating and Drinking Establishment spaces over 10,000 sf, per the requirements of the New Construction Parking Ratios in the section of the Redevelopment Plan.
3. Any expansion or additional square footage to any structure over 20% must conform to the New Construction Parking Ratios in this section of the Redevelopment Plan;
4. Parking ratios for all other uses in Existing Commercial / Retail / Eating and Drinking Establishments are required per the New Construction Parking Ratios in this section of the Redevelopment Plan.

Notes:

1. When the formula or parking spaces required results in a fraction of a space exceeding 0.49, a full space shall be required;
2. Gross Floor Area is the total interior floor area of all floors determined by measuring the inside dimension of the outside walls of the structure;
3. Up to 10% of the required parking stalls may be designated for compact cars;
4. Outdoor seating areas do not count toward the required parking ratios;
5. Accessory uses do not require parking;
6. All surface parking shall be screened based on the Design Standards indicated in the Streetscape section of this Redevelopment Plan;

- * Outdoor seating does not count toward the required parking ratio. Restaurants with under 600 sf of seating and customer queuing area do not require parking.
 - ** Employee parking is based on the number of employees per shift.
 - *** For uses without seating, the Retail/Commercial parking requirements shall apply;
 - **** See Section 3.1 Rehabilitation Standards for additional parking standards. For uses not specifically stated refer to Section 175-13.1 of Off-Street Parking Regulations in the City of Hackensack Zoning Ordinance.
3. **Adaptive Reuse / Rehabilitation of Existing Structures:** The Planning Board, at its discretion, may waive up to 50% of the required parking for each use proposed in an adaptive reuse or rehabilitation project, where those uses will occupy existing buildings within the Rehabilitation Area that cover over 90% of existing lot area and where the building footprint is not being modified. Applicants who cannot fit required off-street parking on the same site as a proposed development may request consideration by the Planning board for the use of the PIP ordinance (Chapter 26, Article VI: Payment In Lieu of Parking) within the City of Hackensack Zoning Ordinance.
 4. **Parking Space Locations and Access:**
 - a. No surface parking or maneuvering space is permitted within any required yard, except driveways providing access to the parking area from the street or connecting two parking areas may be installed across these areas.
 - b. Dead-end parking aisles shall include a bump out or circle to allow vehicles to safely reverse out of spaces at the end of the aisle;
 - c. Columns and walls of structured garages or parking structures shall not encroach into the required parking space width;
 - d. Off-street tandem parking is prohibited;
 5. **Electric Vehicle Parking and Charging Stations:** Projects shall provide electric parking spaces in accordance with §175-13.1.F of the City’s Zoning Ordinance and any applicable State Standards.
 6. **Shared Parking:** A determination of the actual parking requirement for the Project shall be based upon the shared parking opportunities provided by the mixed-use nature of the projects. The Applicant shall be required to submit a shared parking analysis as part of the site plan application before either the Planning Board. The

TABLE No. - Parking Occupancy Rates						
Land Use	Time Period					
	Weekdays			Saturday & Sunday		
	8am-6pm	6pm-Midnight	Midnight-8am	8am-6pm	6pm-Midnight	Midnight-8am
Education	100%	20%	5%	10%	10%	5%
Entertainment	40%	100%	10%	80%	100%	50%
Hotel	80%	100%	100%	80%	100%	100%
Institutional	100%	20%	5%	10%	10%	5%
Office	100%	20%	5%	10%	10%	5%
Theater	40%	80%	10%	80%	100%	10%
Religious	20%	40%	5%	100%	50%	5%
Residential	60%	100%	100%	80%	100%	100%
Restaurant	70%	100%	10%	70%	100%	20%
Retail/Commercial	90%	80%	5%	100%	70%	5%

Figure 2.9: Occupancy Rates Table

shared parking analysis must be prepared by a qualified parking expert or licensed professional planner based on the anticipated hours of operation and specific operational characteristics of the anticipated users in the proposed development. The shared parking study should include the following steps;

- a. Determine the minimum parking requirement for the individual uses in the development project- The minimum number of parking spaces that are to be provided for each use shall be based on the parking ratios included in this redevelopment plan;
- b. Adjust for shared parking- The minimum parking requirement for each use shall be multiplied by the “occupancy rate” as indicated in the table below at Figure 2.9. The applicant and its professionals shall provide documentation to the Board demonstrating the occupancy rates for any proposed land uses not included in the table. Absent documentation, which is subject to review and approval by the Board, 100% of the required parking shall be included in the Shared Parking Study for each time period;
- c. Tabulate the minimum parking requirement for each time period- Sum of the adjusted minimum parking requirements for each land use for each of the six time periods shall be calculated to determine an overall project minimum parking requirement for each time slot;
- d. Total minimum parking requirement- The highest parking requirement for any of the six time periods shall be the minimum parking requirement for the mixed use development project;
- e. In the event there is a change in the size, distribution or use of any of the project components, the property shall be required to appear before the approving Board to demonstrate that the modifications do not negatively affect the results of the approved Shared Parking Study and analysis. Any change that results in a parking deficiency will require variance relief;
- f. The Shared Parking Study is subject to review and approval by the Board and its professionals. If the shared parking analysis is deemed acceptable, the Board may relax the aggregate total of required parking spaces to account for the shared use of the provided spaces. The application and acceptance of this policy is at the sole discretion of the approving Board;

7. **Existing Non-Conforming Parking:** Existing non-conforming parking spaces, areas, and related on-site circulation shall be removed if the property undergoes a change of use or expansion. However, no additional parking is required for the reuse of an existing building, or due to the removal of non-conforming parking.

8. **On-Street Parking Spaces:** Parking spaces located along the portion of a public street(s) fronted upon by a retail or commercial use may be counted toward the minimum number of parking spaces as required by this ordinance. Those on-street parking spaces must be located on the same side(s) of the street as the use and have a length of at least 22 feet.

- a. Tandem on-street parking spaces are encourage on Main Street and require at least 22'-0” in length with a minimum 6'-0” striped or demarcated ingress/egress space between each set of parking spaces.
- b. In the event any on-street parking which was counted toward the minimum requirement is removed by the City subsequent to the approval of the development, the existing use will not be required to make up the difference;

Total Number of Parking Spaces in Parking Facility (Lot or Garage)	Minimum Total Number of Accessible Parking Spaces Required	Minimum Number of Van Accessible Sparking Spaces
1 - 25	1	1
26 - 50	2	1
51 - 75	3	1
76 - 100	4	1
101 - 150	5	1
151 - 200	6	1
201 - 300	7	2
301 - 400	8	2
401 - 500	9	2
501 - 1000	2% of total	
1001 and over	20, plus 1 for each 100, or fraction thereof, over 1000	

Figure 2.10: ADA Accessible Parking Space Ratios

9. **Off-Site Parking Standards:** Parking standards may be met on-site or off-site at the discretion of the Planning Board. In order for the off-site parking to count toward the minimum parking requirements, it shall be located within 800 feet from the permitted use on either a Municipal Lot or on a property owned by the developer. Off-site parking must be maintained so long as the use of the building remains. In the event of a change in use or density, parking requirements shall be adjusted to meet the standards for the new use.
10. **Bicycle Parking:** Bicycle parking is required for new developments at a rate of one bicycle parking space for every 50 vehicle parking spaces, up to 200 vehicle parking spaces.
 - a. Thereafter, one bicycle parking space shall be provided for every 100 vehicle parking spaces. Fractions equal to or greater than one half resulting from this calculation shall be considered to be one bicycle space;
 - b. Bicycle parking shall not be located in a front yard or in the right-of-way on Main Street;
11. **Structured/Underground Parking Decks:** Residential developments, including mixed or multi-use with a residential component, can provide security for residents by controlling vehicular and pedestrian access to structured or underground parking in areas designated for the residential parking;
12. **Handicapped Accessible Parking Requirements:** Refer to Figure 2.10 for the accessible parking space requirement.
13. **Additional Off-Street Parking Regulations:** For all parking standards not covered in this section or in section 2.7, "Screening Standards", of this Redevelopment Plan, refer to Section 175-13.1 of the City of Hackensack Zoning Ordinance with the exception of the following:
 - a. Off-street parking dimensions shall be 9'-0" x 18'-0" ;
 - b. Two lane drive aisle dimensions for 90-degree (perpendicular) parking spaces shall be 24'-0";
14. **Loading Standards:** Buildings and structures, excluding parking structures, subject to the provisions of this section, must provide a minimum number of off-street loading spaces. These spaces must be designed and constructed so that all loading maneuvers take place within the property line, service alley or secondary street. These loading spaces shall not interfere with the normal movement of vehicles and pedestrians in the public rights-of-way, unless otherwise approved.

These loading spaces must be provided in accordance with the following:

- | | |
|--|----------------------|
| - Less than 25,000 square feet: | None Required |
| - 25,000 - 50,000 square feet: | 1 bay + 1 compactor |
| - 50,000 – 100,000 square feet: | 2 bays + 1 compactor |
| - 100,000 – 150,000 square feet: | 2 bays + 2 compactor |
| - Each additional 100,000 square feet: | 2 bays + 1 compactor |

For grocery stores / supermarket:

- | | |
|-------------------|-----------------------|
| - 50K square feet | 2 bays + 2 compactors |
|-------------------|-----------------------|

For non-residential use with five (5) or more off-street loading parking spaces, 40 percent of the spaces must be large enough to accommodate vehicles greater than 30 feet long.

Off-street loading and unloading shall be provided in such amount and manner that all loading and unloading operations will be conducted entirely within the boundaries of the lot concerned, and no vehicle shall use public streets, sidewalks or rights-of-way for loading or unloading operations, other than ingress and egress to the lot.

2.7 Screening Standards:

The provisions of this section shall be met at the time land is developed or the land and structures are redeveloped. The requirements of this section do not apply to lots or portions of lots, which are vacant or undeveloped.

1. **Off Street Parking:** All proposed off street parking areas with 25 spaces or more shall be screened from all public streets with the following criteria:
 - a. A 4 foot minimum planting strip shall be located between the back of the public sidewalk and the parking area;
 - b. The planting strip shall be planted with evergreen shrubs at least three feet high at the time of planting which are a species that will form a year round dense screen. The maximum height for planting should be maintained at no greater than 4 feet in height;
 - c. Perimeter trees shall be planted at no greater than 25 foot on center based on the perimeter length of the parking area and should be trimmed up to 8 feet in height at the time of planting;
2. **Interior Landscape Planting:** All open parking areas of 36 or more parking spaces or at least 12,000 square feet in area shall provide at least one 4 inch caliper tree for every 8 parking spaces which include perimeter trees. (See Section 3: Design Standards for minimum street tree requirements.)
 - a. Fractions equal to or greater than 0.5 resulting from this calculation shall be considered to be 1 tree;
 - b. Each such tree shall be located in a planting island with a minimum area of 150 square feet of pervious surface;
 - c. The following distribution of trees shall apply:
 - Each end space in a row of 12 or more parking spaces shall fully abut a planting island or a perimeter landscaped area along the long dimension of the end space;
 - No more than 20 parking spaces shall be permitted between planting islands, or a planting island and a perimeter landscaped area;
3. **Required Screening:** The following uses or site elements must be screened from abutting property and from a public street:
 - a. Dumpsters, recycling containers (except for recycling containers located at recycling collection centers), or solid waste handling areas;
 - b. Service entrances or utility structures associated with a building, except in the area where such use abuts other service entrances or utility structures;
 - c. Loading docks or spaces, except in the area where such use abuts other loading docks or spaces;
 - d. Utility meters, HVAC equipment, generators, transformers, and similar equipment, structures, or mechanisms at ground level.
 - e. Outdoor storage of materials, stock and equipment; and
 - f. Any other uses for which screening is required under these regulations;
4. **Landscape Buffer:** Any screening or buffer areas used to comply with the provisions of this section or other ordinance provisions, for uses other than parking decks, must consist of a planted area which is at least 4 feet wide.
 - a. This area may contain any type screening materials sufficient to visually separate land uses on separate lots, provided such materials meet the requirements of this section;
 - b. If a wall or fence is used, then the buffer shall not require shrubbery, but shall require trees where the proposed building is at least two-stories in height. The composition of the screening material and its placement on the lot will be left up to the discretion of the property owner, so long as the purpose and requirements of this section are satisfied;

5. **Installation Requirements:** The following contains standards to be used in installing screening:
- a. Trees must be installed with a minimum 4 inch caliper and must be large deciduous or evergreen species which have a minimum growth height of 25 feet; (See Section 3: Design Standards for minimum street tree requirements.)
 - b. Trees should be trimmed up 8 feet at the time of planting;
 - c. Shrubs used in any screening or landscaping must be evergreen, at least 3 feet tall with a minimum spread of 2 feet when planted and no further apart than 4 feet. They must be of a variety and adequately maintained so that an average height of 3 to 4 feet could be expected as normal growth within 4 years of planting. Shrubs and trees shall be approved by the City Engineer;
 - d. Any fence or wall used for screening shall be constructed in a durable fashion of brick, stone, other masonry material, specifically designed for fencing or wall construction purposes;
 - e. A fence used for screening in accordance with this Redevelopment Plan shall be entirely closed, or opaque. A chain link fence with plastic, metal or wooden slats cannot be used and does not satisfy the requirements of this section;
 - f. The maximum height for a wall or fence is 4 feet, except that a fence as tall as 6 feet shall be permitted along a property line abutting a one- or two-family dwelling or as may be deemed appropriate by the Planning Board where the application concerns a public use and is necessary for public safety;

3 Design Standards

3.0 Development / Place-Making Design Standards:

The design standards in this section provide the criteria for existing and proposed development within the Main Street Rehabilitation Area in order to promote a high quality, pedestrian friendly, mixed use environment. Any future development is subject to these provisions and should be built in accordance with the minimum design standards specified in this section. These standards promote:

- a. Appropriate scale for Main Street and the Rehabilitation Area;
- b. Standards for commercial, office, residential and civic uses;
- c. Mixture of architectural styles with;
 - i. Respect for the character of existing historic buildings;
 - ii. Contemporary design for new development;
 - iii. Unified streetscape design;
 - iv. New construction with an emphasis on modern materials and construction methods;

1. Architectural Character - Relation to Surroundings

- a. All buildings shall reinforce pedestrian scale.
 - i. The base of buildings shall be distinguished from the remainder of the building with an emphasis on providing design elements that will enhance the pedestrian environment particularly at the street level;
 - ii. Special attention must be given to the design of windows at the base of buildings. Ribbon windows are discouraged. Recessed windows are encouraged which are distinguished from the shaft of the building through the use of arches, pediments, mullions, and other treatments;



Figure 3.0: Buildings promote pedestrian scale with first floor retail to activate the street



Figure 3.1: Building facades should be varied



Figure 3.2: Buildings fronting Main Street should have retail on the first floor with unique and individual storefronts to provide variety.

2. **Facade Articulation**

- a. Building facades in excess of 120'-0" in length shall be designed to avoid a monolithic appearance through the use of different façade materials and at least one building step back or the incorporation of balconies/bay windows for each 120'-0" that act to break the building appearance into smaller increments and sections.
 - i. For buildings in excess of 120'-0" in length, a vertical demarcation should be included at a minimum of every 60'-0" of building façade;
- b. Elements should be provided to add special interest to the base, such as cornices, belt courses, corbelling, molding, string courses, ornamentation, changes in material or color, and other sculpturing of the base;

3. **General Building Materials**

- a. Building materials may include: brick, stone, cast stone, stucco, metal and glass storefront assemblies, wood and fiber cement siding;
 - i. Brick, stone, cast stone, and/or glass shall cover a minimum of 65% of each building façade, exclusive of windows and doors with accent materials, which shall comprise the remaining 35% for each building façade;
- b. Vinyl siding of any type and grade is strictly prohibited on any portion of any building façade within the Rehabilitation Area;

4. **Ground Level Uses**

- a. First level commercial, retail and office may be designed using different



Figure 3.3: Unique retail storefront on first floor of mixed use development



Figure 3.4: Storefront should support and enhance good pedestrian experience



Figure 3.5: Merchandising may include elements that enhance the tenant's brand such as planters, furniture, and displays

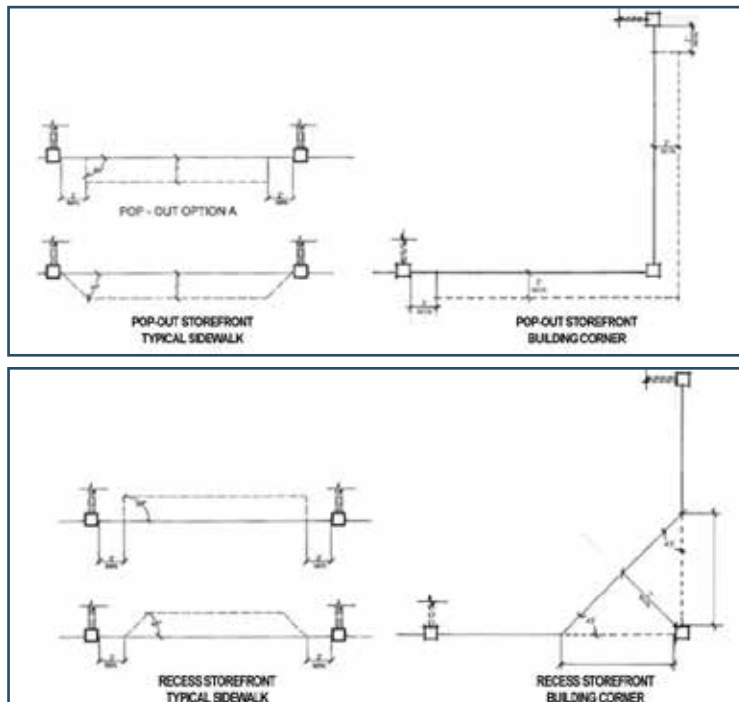

Figure 3.6- First Floor Retail Pop-out example



Figure 3.7: Storefronts should exceed the quality of the base building design

material than the levels above;

- i. First level facades should be varied and avoid monolithic appearance;
 - ii. Generic national branding architecture for freestanding retail / commercial buildings is prohibited unless it meets the requirements of this section;
 - iii. Storefront design should reflect the individual tenant's brand identity;
 - iv. All new commercial and retail first floors shall have a 16'-0" minimum floor to floor height;
- b. The design of Banta Place should consider closing the street on weekend nights for outdoor dining and public events;
- i. The design of the street should consider removing the curb and gutter and providing a special paving material such as cobblestone to create a flexible public space that would support outdoor dining;
 - ii. Consideration should be made for tivoli lighting across the street;
 - iii. Daytime and emergency access should be considered along with access to the Post Office;
- c. Temporary / semi-permanent outdoor dining and seating is encouraged within the 18'-0" setback for retail and restaurant uses located on Main Street;
- i. Seating is encouraged to be designed either along the building façade or at the back of the curb. These areas should be clearly identified with either temporary, semi-permanent barriers that are removed at the end of each night or permanent barriers;
 - ii. A minimum six foot (6'-0") clear zone must be maintained within the building setback in order to allow adequate pedestrian flow;
 - iii. Outdoor seating shall not count toward the total number of seats for the establishment or for parking requirements.
- d. For storefronts, refer to "5. Storefront Design Standards"

5. Storefront Design Standards

a. General:

- i. Great retail streets are comprised of great retail storefronts. As a part of the public space, storefronts

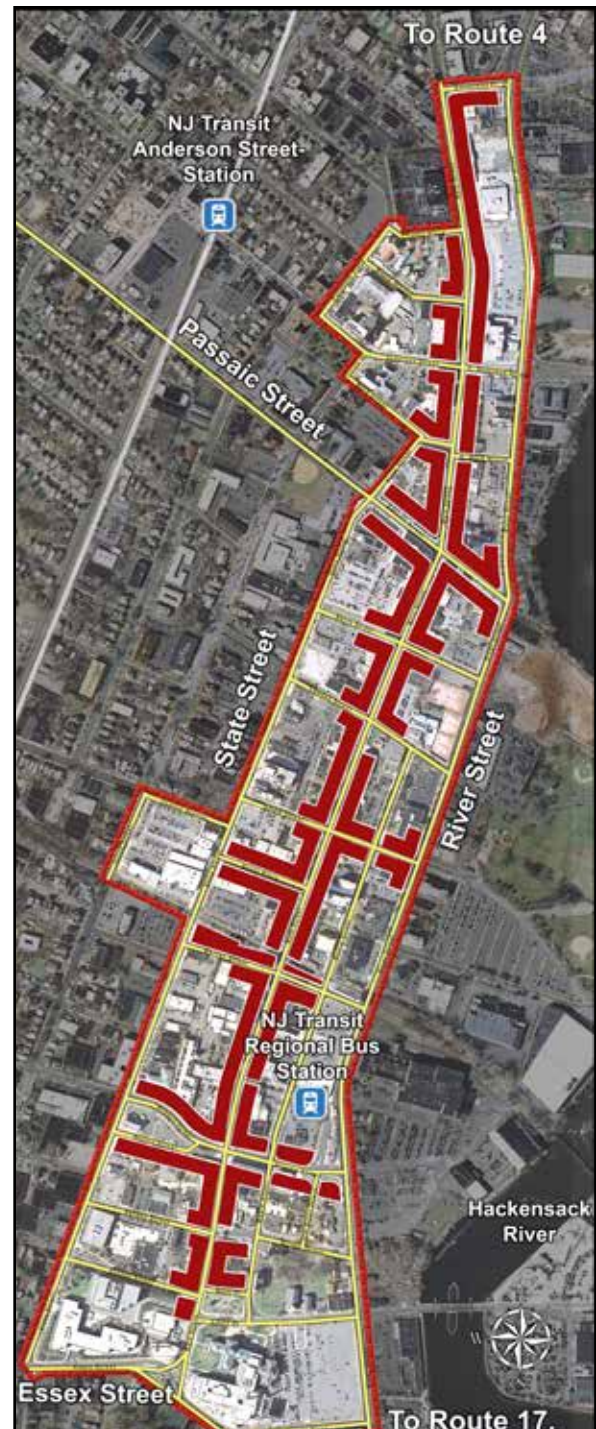

Figure 3.8: Recommended first floor retail locations

are a critical component of a street's vibrancy and character. Therefore, the City encourages a variety of unique and engaging storefronts to collectively form a great retail street. First and foremost, creativity is strongly encouraged. These criteria are established less as a set of rules, and more as a benchmark, or starting point, for making exciting storefronts. In addition to storefront design, retailers can actively contribute to their location's streetscape. Elements such as awnings, planters and outdoor seating increase visibility, enhance connections to the sidewalk and create interest.

- ii. All retail tenants can have the opportunity to design and install their own storefronts as a way to express their individual identity and positioning provided they observe the minimum guidelines noted below:

- Storefronts should be "individual" expressions of a tenant's identity;
- Tenants will be encouraged to avoid cookie cutter representations of their identity and to create an expression that is complementary to the architectural vocabulary of the street;
- Tenant's storefront construction should be of high quality and craftsmanship. Tenants are encouraged to use real, durable materials in the interpretation of their identity;
- Store color palettes should take into consideration and strive to complement or integrate the overall color palette of the buildings on the block;
- With review and approval by the City, and agreement from the landlord, tenants may be allowed to express their identity beyond the façade in the form of banners, awnings, flower boxes, etc.;

b. Storefront Components:

- i. **Entries & Doors:** The placement of doors and their design are an integral part of the storefront because they establish a clear point of entry to the store. Creative uses for entry doors should be explored as a connection to the street. Restaurants especially should use doors to open interior seating spaces to the outside café seating on the sidewalk;
- ii. **Canopies & Awnings:** An awning or canopy emphasizes the store or restaurant's entrance, provides shade for a café, and can carry part of a tenant's identity. It can also add texture to the streetscape, and add interest and variety to the building façade;



Figure 3.9: Storefronts should be transparent



Figure 3.10: Canopies can overhang 8'-0" over the sidewalk into the ROW



Figure 3.11: Outdoor dining is encouraged to wrap building corners and front on public spaces



Figure 3.12: Storefront should express tenant identity

iii. **Windows & Glazing:** The use of glazing in retail storefronts creates an important connection between the interior and exterior environment, and allows for effective window shopping and merchandising opportunities. Glazing elements also play a key role in establishing the quality of public space. Storefronts are required to be a minimum of 75% transparent from the street;

- Windows and interior layouts for retail type uses should permit unobstructed visibility of at least 12 feet into the establishment;

c. **Storefront Materials:**

i. The approach to storefront design should be to create the highest quality level possible with an emphasis on user-friendly materials. The overall objective in developing the exterior storefront design is to specify “real” materials at the pedestrian level. A variety of masonry materials such as brick, stone and pre-cast are suitable. Masonry detailing, molding, finished metals, glass enhancements and high quality paint treatments will contribute to a successful retail environment. The minimum recommendations below, outline some of the specifics when considering materials for storefronts:

- Construction detail and finish should adhere to craftsman’s standards;
- Focus should be on window design to create a visual connection between the interior and exterior;
- Recommended materials are wood, metal, brick, stone, glass and concrete as well as plaster;
- Acceptable materials are durable, smooth exterior grade woods such as oak, redwood and poplar;
- Durable materials are especially critical at street level where pedestrian contact will be considerable. Consequently, these types of materials are required below 12’-0” AFF on the storefront. EIFS or similar materials are not



Figure 3.13: Awnings over the street and outdoor dining are encouraged



Figure 3.14: Canopies should be a minimum of 10’-0” above sidewalk grade



Figure 3.15: Outdoor dining should be separated from the sidewalk with a 6’-0” pedestrian clear zone

permitted below this dimension;

- Storefronts should be predominantly glass to provide views into the store, but glass should not be the exclusive material;
 - Materials should be authentically portrayed and code compliant;
- ii. The following materials are not permitted for storefronts in new development: (See Rehabilitation Standards for renovation standards for existing storefronts)
- Plastic and metal laminates;
 - Acrylic;
 - Plastics;
 - Smoked or tinted glass;
 - Anodized or mill finish aluminum;
 - Simulated materials;
 - Interior grade materials and wall coverings;
 - Distressed or sandblasted woods;
 - Rough-sawn woods and shakes;
 - Mirror;
 - EIFS;

6. **Building Orientation:** All buildings shall be oriented toward public streets and public open spaces. The building front shall be considered to be any elevation facing any public street.
- a. A building that is adjacent to a park, plaza or open space should orient to both the public street and the open space.
 - b. The first floors of all buildings, including structured parking, must be designed to encourage and complement pedestrian-scale activity. It is intended that this be accomplished principally by the use of windows and doors arranged so that the uses are visible from and/or accessible to the street on at least 75% of the retail or commercial length of the first floor street frontage;
7. **Building Entrances:** Building entrances should be easily identifiable and feature large, open and transparent windows with unique and interesting signage. (Operable windows are encouraged)
- a. Retail entrances can have up to a 2 foot pop-out / protrusion / recess into the required setback for columns or other architectural features that distinguish the commercial or retail storefront;
 - Tenants may use this area for merchandising projection;
 - b. Entrances for residential, office and uses other than retail should be separate and distinct from retail entrances;
8. **Canopies and Balconies:** Canopies, awnings, and similar architectural accents are encouraged at entrances to buildings and in open space areas. Such features may be constructed of rigid or flexible material designed to complement the tenant's identity at the street level.
- a. Any canopy may extend from the building up to one half of the depth of the setback area in front of the building, or 8 feet, whichever is less;
 - b. Ground supports for these features are not permitted in the minimum setback, sidewalk or in the public right-of-way on Main Street;

- In no instance shall such features extend over or interfere with the growth or maintenance of any required tree plantings;
 - Residential canopies located on secondary streets may have ground supports for these features;
- c. Minimum overhead clearance shall be ten (10'-0") feet. If a canopy, awning, cornice, or other appurtenance extends into the public right-of-way, an encroachment agreement shall be required;
 - d. Balconies/balconettes can be incorporated into the building façade and are allowed to project into the 18 foot setback up to 4 foot starting at the second level;
9. **Mechanical Equipment Screening:** The screening of rooftop mechanical equipment is required.
- a. All rooftop mechanical equipment including cellular communications antennae shall be screened from view from all adjacent public streets, open spaces and parks in all directions and elevations to minimize the negative impact from any public street, residential neighborhood or adjacent building;
 - b. Screening materials shall be consistent with the architectural detail, color and materials of the building;
 - Wire mesh screening is not permitted;
 - c. All rooftop equipment and HVAC systems must be set back a minimum of 15 feet from Main Street and 10 feet from any other public street or public open space from the building edge and screened as to not be visible from any adjacent public street or public property;
 - d. Any wall pack ventilation unit facing a public street must match the adjacent material color;
10. **Building Service Locations:** All service locations for new development shall be provided at the rear or side of the building and shall not be permitted directly on Main Street, Essex Street, Passaic Street and Banta Place.
- a. Existing service locations on Main Street are permitted with designated service drop off areas only. Service vehicles are not permitted to stop in the street and must use a designated service drop off area;



Figure 3.16: Outdoor dining should be separated from the sidewalk with a 6'-0" pedestrian clear zone



Figure 3.17: Outdoor dining should be separated from the sidewalk with a 6'-0" pedestrian clear zone

11. **Doors and Windows:** Where windows are used they must be transparent. Where expanses of solid wall are necessary, they may not exceed 30 feet in length.
 - a. The first floor and street level must be designed to address all public streets and all adjacent public or private open space improvements;
 - b. Buildings fronting on two streets, or on one street and one public plaza or open space, shall provide pedestrian access from the primary street and is encouraged to provide access from the secondary street or public open space;
 - For buildings that do not provide access from the secondary street or open space, the building facade should provide windows and/or architectural details that are aesthetically interesting;
 - c. Operable windows are encouraged at the street level;
 - d. No development may have exterior walls with a reflectivity value in excess of 35 percent;
12. **Structured Parking:**
 - a. Structured parking shall be screened with uses along Main Street and Banta Place;
 - b. Structured parking shall be screened with either uses or shall include decorative architectural details such as building materials, windows and detailing along all other streets in the Rehabilitation Area;
 - Architectural detail elements should have the same or similar materials and should have the same or similar scale for openings as the residential / commercial building above;
 - Other than at the parking entrances vehicles shall not be visible from the center line of either public street;
 - c. All ramps shall be internal to the parking structure and shall not be visible from any public street;
 - Cabling or exposed concrete alone does meet the screening requirement;
 - d. Driveway and garage openings should not exceed 28'-0" and should include traffic calming measures and a change in surface materials where driveways cross the sidewalk to help ensure pedestrian and bicycle safety;
13. **Openings / Ventilation:** Any openings for ventilation, service, or emergency access located at the first floor level in the building facade must be decorative and must be an integral part of the overall building design.
 - a. These openings as well as pedestrian and vehicular entrances must be designed so that cars parked are not visible from the street;
14. **Urban Open Spaces:** Providing open space for new developments with a gross floor area greater than 100,000 square feet is strongly encouraged.
 - a. Open space that is provided shall be located at the street level as a plaza, park, or within a public lobby;
15. **Environmental and Sustainable Design:**
 - a. Pervious surface and / or storm-water management systems will be required for any proposed development to reduce the impacts to the City's sewer system. Infrastructure improvements would include but not limited to green roofs, planter boxes and trays, permeable pavers and above or below grade storm-water management systems;
 - b. The improvements shall be provided in order to ensure that the post-construction peak runoff rates for the 2 year, 10 year, and 100 year storm events are a maximum of 90 percent of the pre-construction peak runoff rates.

3.1 Rehabilitation Standards:

1. Introduction / Background Information:

Preserving elements of the City of Hackensack's architectural heritage is a vital and valuable element for the creation of a pedestrian friendly mixed use urban environment. The Rehabilitation Area has a number of potential properties that could be preserved or rehabilitated which include but are not limited to the properties identified in Figure 3.18. The determination for preservation or rehabilitation should include the following considerations:

- a. Age of the structure;
- b. Structural / historic integrity;
- c. Overall contributing historic character;
- d. Adaptability to new or improved use;
- e. Symbolic significance;
- f. Visibility and prominence;

2. Rehabilitation Standards:

For buildings being proposed for rehabilitation, renovation and adaptive reuse that are located in the Rehabilitation Area the following items should be considered:

- a. The City of Hackensack "Main Street, Hackensack, NJ Historic Walking Tour" survey should be reviewed to determine whether or not the property has architectural or historic significance;
 - In the event, architectural elements are uncovered during a renovation, efforts should be made to preserve and accentuate those elements;
- b. The following Block and Lots shall preserve / enhance any historic portion (as identified in the "Main Street Hackensack, NJ Walking Tour) survey of the existing building facades that front a public street (not including parking);

- Block 64 Lot 1 (15 Court Street)	- Block 208 Lot 30 (41-43 Main Street)
- Block 202 Lot 8 (42 Court Street)	- Block 205 Lot 1 (14 Washington Place)
- Block 304 Lot 1.01 (179 Main Street)	- Block 409 Lot 14.01 (5 Anderson Street)
- Block 314 Lot 1 (226 State Street)	- Block 315 Lot 32.01 (241 Main Street)
- Block 312 Lot 18 (274 Main Street)	- Block 405 Lot 3 (440-468 Main Street)
- Block 411 Lot 2.02 (32-44 Maple Avenue)	- Block 407 Lot 34 (355 Main Street)
- Block 314 Lot 9.01 (237 Main Street)	- Block 201.02 Lot 8 (104 State Street)
- Block 209 Lot 5 (27 Warren Street)	- Block 208 Lot 29 (47 Main Street)
- Block 205 Lot 3 (60 Main Street)	- Block 206.01 Lot 7, 14, 15 (78 - 82 Main Street)
- Block 210.01 Lot 17.02 (135-137 Main Street)	- Block 311 Lot 10 (200 Main Street)
- Block 312 Lots 14.01, 14.02, 14.03, 14.04, 14.05 (262 - 270 Main Street)	
- c. Enhancements shall include but are not limited to reopening windows and doorways, restoration of historic details in addition to enhancements of historic elements.
- d. Any interior renovation that does not expand the existing square footage over 20% may be done without meeting the design standards of the Redevelopment Plan;
 - Any expansion or additional square footage to any structure over 20% must conform to the Design Standards of the Redevelopment Plan;

- Any change to the exterior signage shall require all signage to conform to the signage requirements of the Redevelopment Plan;
- e. Deteriorated architectural features should be repaired instead of being replaced where feasible. In situations where replacement is necessary, the same materials are encouraged to be used and the replacement should meet the same visual, design, composition, color and texture of the original feature;
- f. Any additions or repairs to over 50% of the façade which are visible from any street should meet the architectural style and intent of the original building based on the historic time period in which it was originally constructed or meet the Design Standards of the Redevelopment Plan unless seeking a variance;
 - For structures with new uses, non functional features that diminish the marketable value may be removed so long as they do not diminish the historic nature of the building as seen from any public street;
 - Existing non-conforming buildings may remain;
- g. Any existing building may change its first floor use to a restaurant without requiring additional parking, so long as the change in use does not propose more that a 20% expansion of the existing building square footage;
 - All submittal, review and approval requirements other than parking are required;



Figure 3.18 - Block and Lots to preserve existing building facades facing a public street.

3.2 Streetscape Design Standards:

A successful neighborhood is not complete until its parks, open space, sidewalks and streetscape have been designed and “furnished”. The items that are referred to as streetscape elements in this guideline include such things as street lights, sidewalks, benches, trash receptacles and other street furniture which reinforce the character of the street and the neighborhoods. The following section addresses an overall approach for the design of streetscape elements that are to be considered as part of the overall Redevelopment Plan vocabulary. These standards are meant to establish the minimum criteria that will be required for the design and implementation of streetscape, parks and open space improvements.

As a part of the revitalization of the Rehabilitation Area, the City of Hackensack will develop specific streetscape standards for Main Street and the other streets in the Rehabilitation Area. All new buildings and developments in the Rehabilitation Area, with the exception of renovated and rehabilitated buildings, must meet the following minimum standards.

1. **Rehabilitation Area Streetscape:** The streetscape for the Rehabilitation Area should be designed with a similar palette of materials and standards in order to portray a cohesive downtown district.
 - a. **Main Street:** The streetscape for Main Street and Banta Place shall provide a higher standard for the design elements;
 - b. The specific paving colors, materials, and palettes should be the same for certain blocks but varied along the length on Main Street so as not to create a single monotone street pattern. Redevelopment of entire blocks should encourage developers to explore alternative patterns and colors of paving materials;
2. **Streetscape Elements:** For projects in the Rehabilitation Area the following streetscape elements shall be provided per this section of the Design Standards:
 - ◇ Street trees;
 - ◇ Lighting;
 - ◇ Furniture;
 - ◇ Pavers;
 - ◇ Materials;

Proposed development projects shall provide these elements as a part of the approval process.

- a. **Street Trees:** Street trees shall be planted in either grates or open landscape areas equivalent to 30'-0" on center along all public street frontage for any new project/development.
 - Recommended street trees: Main Street: Gleditsia Tricanthos (Honey Locust - thornless and pod free) - Other Street: Platanus × acerifolia (London Plane Tree);
 - Trees should be installed at a 4" caliper;



Figure 3.19 - Streetscape with lighting/bench



Figure 3.20 - City of Hackensack bench



Figure 3.21 - Varied paving pattern



Figure 3.22 - Bus shelter with seating and trash receptacle



Figure 3.23 - Street tree guards

- Prior to installation a 4 foot by 8 foot minimum area should be treated and prepared for tree root growth;
- A minimum 2 year watering plan should be put into place (Gator bags);
- Main Street and Banta Place shall plant street trees in grates. The remaining streets should be planted in a minimum 4 foot x 8 foot landscape area;
- For buildings located adjacent to public open spaces, parks or plazas, trees may be planted in open grass areas;
- Above ground planters may be considered to fulfill the street tree requirement only in situations where underground utilities prevent tree pits;
- Street trees shall be planted with a minimum four inch 4" caliper, shall be trimmed up to 8'-0" and shall be in accordance with the "American Standard for Nursery Stock" published by the American Association of Nurserymen;
- Street tree species can vary along Main Street so long as the same species is used for a minimum of two block lengths and for both sides of the street. (Accent flowering trees may be used to denote special areas, parks, plazas, etc.);
- Street tree species for all secondary streets with the exception of State Street and River Street shall have a single species of tree for the entire length (Accent flowering trees are permitted to denote special areas.);

b. Sidewalks:

- Sidewalks should be comprised of a "pedestrian zone" nearest the facade for building access and window shopping and a "furniture zone" nearest the curb for trees, plantings, street furnishings and cafe seating when there is sufficient width;
- The 4'-0" street furniture area should include Belgard Catalina (Color: Bella) for the area between Passaic Street and Atlantic Street. <http://www.belgard.com/products/pavers/urbana-ston>;
- Random pattern using four different sizes (4"x8"; 8"x8"; 8"x12"; and 12"x12"). The pattern should be done as to not require any cutting of the pavers;
- Pavers will be set in sand;
- Sidewalks shall be concrete on secondary streets;
- Openings/grates for plantings should be provided in the furniture zone and should be consistent with street tree plan;

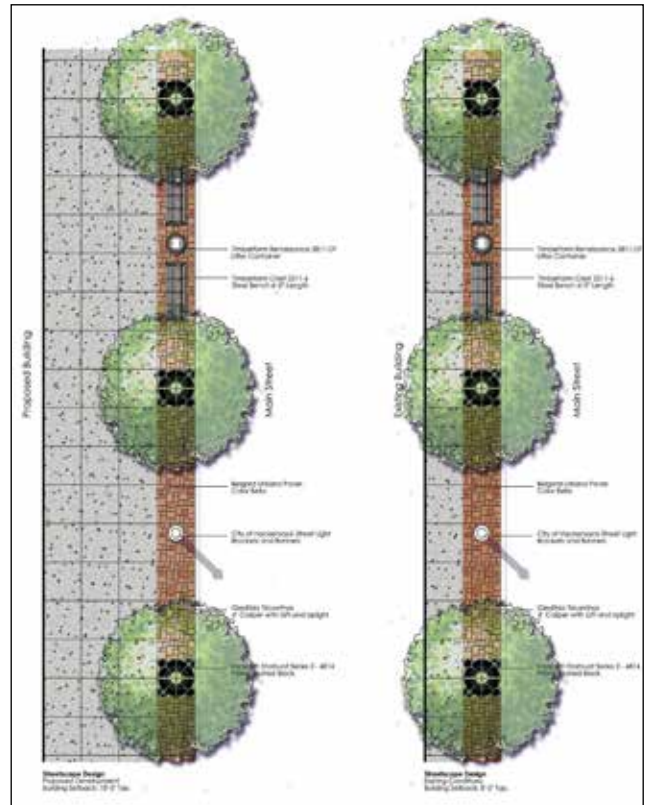

Figure 3.24 - Streetscape Design

- Open landscape planting beds shall be located at all Main Street corners and shall include a raised stone curbing;
- c. **Seating, Benches & Bus Shelters:**
- Seating should be grouped together as much as possible and be placed at busier pedestrian nodes or gathering places;
 - Seating should be designed and placed appropriately to provide an amenity to the public;
 - Seating can be manifested in permanent planter edges;
 - Seating should not obstruct views for vehicles, sidewalks for pedestrians, or signs and displays for businesses;
 - Seating should blend in with the surroundings or be specified in a complementary accent color;
 - Outdoor cafe seating should also follow the guidelines listed under Street Level Frontage / Uses of this section and recognize the designated amenity zone;
 - Bus shelter locations should be coordinated with streetscape design;
 - Benches should be Timberform Crest 2311-6 Steel Bench with middle arm rest 6 foot long anchored to sub-grade concrete slab with black finish;
 - Two benches and one trash receptacle should be located between street trees where street lights are not located and should be at minimum every 90 feet on center;
- d. **Lighting and Power;**
- All street lighting within the Rehabilitation Area shall be the City of Hackensack city standard pedestrian scale light pole, and fixture, black finish;
 - Poles should include the mounting brackets and banner extensions (two banners) on each pole;
 - GFI receptacle should be located at the top of the pole;
 - The conceptual layout was based on 16 foot pole every 90 feet on center. This should be verified with the photometric design;
 - The height and spacing of the light poles should be based on a photometrics calculations;
 - Lights should be centered between the street trees within the 4 foot street furniture zone;
 - Street light specifications and locations shall be submitted for review and approval prior to installation;
 - Street lights should be located as part of the streetscape and function as a unifying element of other streetscape items including

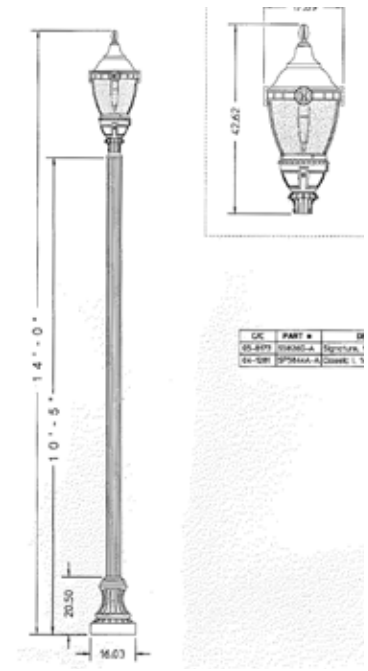

Figure 3.25 - Typical street light

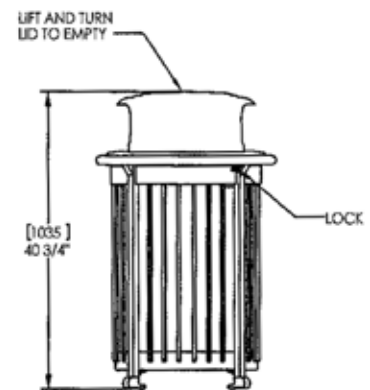

Figure 3.26 - Typical trash receptacle



Figure 3.27 - Bicycle rack example



Figure 3.28 - Bollards with lighting example

- trees, benches and paving;
 - Fixtures should exhibit an aesthetic as well as functional purpose to create interest and a sense of scale for the pedestrian;
 - Luminaires should be translucent or glare-free using opaque glass or acrylic lenses;
 - Diffusers and refractors should be installed to reduce unacceptable glare; particularly adjacent to residential areas;
 - 120 V ground mounted GFI receptacles should be located at the base of every street tree;
 - Tree up lighting fixtures should be located at the base of every street. (Atlantic Street Park specified Hadco #BT1-AL, 75 W MR16 Lamp or equal);
 - Conduit for all power should be located at the back of the 4 foot street street furniture area (under the pavers) and next to the concrete sidewalk;
- e. Planting Pots & Planters:
- Pots and planters should be used in addition to landscape planting areas to complement the surrounding streetscape by adding color and variety;
 - Pots and planters can be placed anywhere pedestrian or vehicular traffic is not disturbed, but may function as a separation between pedestrians and vehicles;
 - Large pots are preferred to fixed boxes to allow for maintenance or service access;
 - Pots and planters are ideally located near seating areas, but plant materials should not interfere with circulation or comfort;
- f. Tree Grates:
- Tree grates should be Ironsmith Starburst Series 2 (4814) Powder coated Black every 30 feet on center;
 - Tree grates should be used wherever a tree is placed within a high traffic area;
 - Tree grates should allow for tree growth and be made of ductile iron and should be factory painted;
 - Electrical outlets should be provided within the grate area to allow for lighting opportunities;
 - Tree grates should be designed to support uplighting;
- g. Trash Receptacles:
- Trash receptacles: Timberform Renaissance Model 2811 - DT Litter Container anchored to sub-grade concrete slab, black finish;
 - Every other receptacle should be: 2817-22 Litter/Recycling Container which includes a second recycling container;
 - Trash receptacles should be located conveniently for pedestrian use and service access in significant areas and gathering places;
 - Restaurants with outdoor seating should provide additional trash receptacles near seating;
- h. Bicycle Racks:
- Bicycle racks should be permanently mounted and placed in convenient locations to encourage bicycle use;
 - Bicycle racks should be placed so as not to obstruct views or cause hazards to pedestrians or drivers;
 - Bicycle racks should exhibit a simple and easy design that allows for convenient and safe use by the public;

- Bicycle racks should not be placed on Main Street within the 18 foot building setback;

i. Bollards:

- Bollards should integrate with and aesthetically complement the overall streetscape concept; respond to the area it supports (Plaza vs Services); setback from curbs to allow unobstructed opening of parked car doors;
- Bollards may be chained or cabled together to ensure pedestrian safety or define areas for public functions;
- Removable bollards should be used where service vehicles need access and for street closures in the event of festivals or community events;



Figure 3.29 - Wall and flag signs

j. Fountains:

- Fountains or water features can be located in key public areas such as parks or plazas;
- Fountains or water features should allow for ample pedestrian circulation on all sides;
- Fountains or water features may be designed to encourage “sitting” or for interaction;



Figure 3.30 - Window sign

k. Public Art:

- Public art should be “accessible”; tie to the history of Hackensack and if possible, should be created by a local source; include water, seating, planting, decorative architectural elements or plaza space design;
- Public art should be visible, but not interfere with pedestrian circulation or create a traffic hazard; made of durable, weatherproof materials; and should be designed to avoid physical hazards;



Figure 3.31 - Primary sign

l. Kiosks:

- Kiosks should be used for retail purpose or to impart community information to the public;
- Kiosks should be positioned to complement and respect other street furnishings such as benches and lighting;
- Kiosks should be accessible and attractive from all sides and well-illuminated;
- Kiosks should be flexible to allow for up-to-date information;
- Consideration should be given to the use of fixed kiosks to project a sense of permanence with other fixed surroundings;
- Kiosks are not required to be fixed and may be mobile to allow for flexibility in public areas;

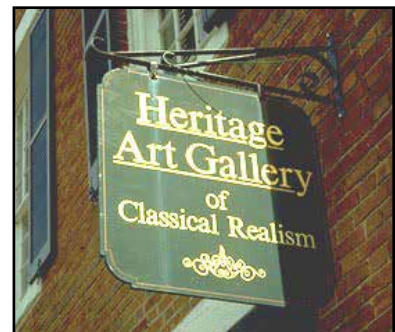

Figure 3.32 - Blade sign

m. Parking Meters:

- Muni-meters and other parking technologies should be used for all on-street parking within the Rehabilitation Area;
- Muni-meters will have dual space capability, there will be one meter pole for every two spaces with the exception of odd spaces on a given block;
- All meters will have black meter poles that match the street furniture and the face of the meter will be Hackensack Blue;

n. Pay Stations

- Pay stations will used for all off-street parking lots;

o. Utility Accessories:

- Utility boxes, meters, man hole covers and fire hydrants should be coordinated with other streetscape accessories;
- Utilities should be readily accessible and placed so as not to obstruct pedestrian movement;
- Utility locations should minimize visual and physical impact as much as possible;
- Utilities should blend in with the surroundings or enhance the area;

p. Intersection Design;

- Bump-outs will not be a typical design for intersections but can be incorporated into certain intersections based on the design engineers recommendations;
- At each street intersection the corner will include an open landscape area (4'-0" x 4'-0" minimum with a raised stone edging with Belgard pavers at soldier course;
- The City will consider an epoxy overlay aggregate and/or design for all crosswalks. (Design and layouts should be presented to the City for review and approval);

3.3 Signage Standards:

1. Signage Standards Overview:

- a. Tenants are encouraged to explore a variety of signage types, sizes and styles with the objective of integrating the design of the signage into the whole storefront design. Storefronts are expected to take maximum advantage of store logos, specialty letter styles, quality materials, graphic flourishes and high impact graphics. This variety is necessary to highlight the diversity of tenants and to support the unique character that defines Hackensack’s Main Street. National or regional stores are specifically asked to consider the special nature of this environment, and look for ways to do something different and even better than is produced in other markets.
 - The goal is to maintain creative consistency that identifies the tenant’s identity and integrates with the storefront façade design;
 - Signs can be in the form of a painted sign, flat sign, fin sign, window sign, illuminated or non-illuminated sign, dimensional sign, sidewalk sign or awnings;
 - Emphasis should be on durable, natural materials and quality manufacturing and can include cast, polished or painted metal; painted, stained or natural wood; glazed and ceramic tile; etched, cut, edge-lit or stained glass; cast stone and carved natural stone;
 - Tenants should strive for creativity, uniqueness and high quality;
- b. For all signage standards not covered or specifically stated in this Section, refer to Section 175-13.4.A through M of the City of Hackensack Zoning Ordinance.

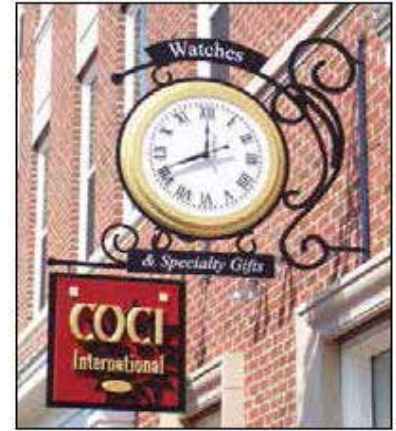

Figure 3.33 - Blade sign



Figure 3.34 - Blade sign



Figure 3.35 - Sidewalk signs



Figure 3.36 - Retail sign locations typ.

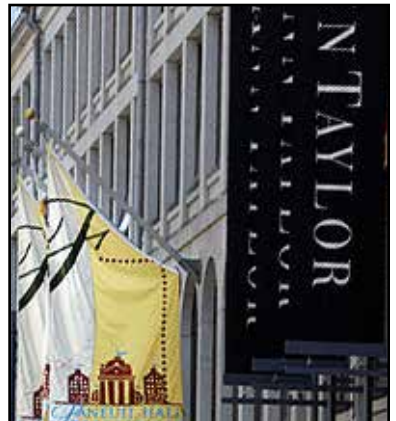

Figure 3.37 - Flag banner signs

2. **Signage Principles:**

- a. Each tenant is permitted two (2'-0") square feet of signage for each one (1'-0") linear foot of storefront. This total signage allocation can be distributed among all signage types;
 - A variety of sign types is encouraged, such as wall mounted, fin, projecting, banner, awning and marquees;
 - A variety of sign illumination is encouraged, such as external, internal, halo, and indirect;

3. **Signage Criteria:**

A variety of sign types is both permitted and encouraged.

- a. **Primary Signs:** Each tenant needs to identify its premises through a Primary sign. The Primary sign refers to a tenant's sign above the entry. The maximum length of lettering permitted to be used on the storefront Primary sign should not exceed 75% of the permitted sign area;
- b. **Secondary Signs:** Secondary signs are those signs that mark a second entrance or corner condition such as would occur on a street corner or at a public place;
- c. **Additional Signs:** A variety of other sign types are permitted and encouraged including;
 - **Projecting Signs:** A projecting sign mounts perpendicular to a building façade and typically hangs from decorative cast or wrought iron brackets, or is firmly mounted to the façade. The use of projecting signs is strongly encouraged. The signs can be painted wood or sheet metal panels with painted, applied or carved letters, logo, crests, insignias and/or images that creatively represent the tenant's identity. Unique shapes and layered applications are encouraged. Projecting signs include blade signs, banners (rigid or soft), and flags. Projecting signs of any type should always be mounted well out of reach of pedestrians;
 - **Blade Signs:** Should be located at a minimum of 10'-0" above finished grade, and should only project a maximum of 2'-6" from the face of the storefront;
 - **Flags & Banners:** Canvas or nylon flags and banners may be used but vinyl banners are discouraged. Flags can be hung perpendicular to the building from poles at or above the third story, or flat against the building. Flag or banner content should be limited to tenant identity, and should not be used for advertisement of specific products or services;
 - A minimum of four locations for banner poles should be considered along Main Street. The poles should be at minimum 20'-0" in height to allow a banner to be hung with a minimum 16'-6" (Clearance should be verified by the Engineer in order to meet all applicable codes);
- d. **Building Address / Identification Signs:**
 - **Building Address Sign:**
 - Should be made of the same or similar materials, letter type, as other signs used by tenants in the building.
 - Maximum sign area: 34 sf for one or multiple business tenants
 - **Building Identification Sign:**
 - May be mounted above the second story on any building four or more stories in height.
 - No part of the sign may be closer than five (5) feet to a side or rear property line or to an

adjacent building

- Permitted one (1) sign per street frontage with a maximum three (3) foot letter height, maximum 25 foot in length and a maximum fifty (50) foot sign area.
- A wall mounted building or business identification sign shall not be located in the same vertical plane as any awning sign displaying the same building or business identification information unless it is mounted on a fifth story or higher.

e. **Temporary Real Estate Signs:**

- Temporary real estate signs shall be permitted for all new construction and for the substantial rehabilitation (over 50% renovations of the interior) of existing structures;
- The temporary real estate sign approval shall expire one (1) year after the date of issuance, and a new permit shall not be reissued for the same sign unless the Building Inspector has determined the sign is not unsightly and is not in need of substantial repair and the inspection fee is paid;
- No temporary sign shall be permitted for more than two years after the date of issuance without a Planning Board review and approval;
- All signs shall be a maximum of four (4) colors (including black and white);
- Temporary Sign Size: A maximum of three (3) temporary signs are permitted on each side of the building, so long as the maximum area of the total signage per side, does not exceed 20% of the area of the side of the building the sign is located on.
- The Zoning Officer has the right to request any Temporary Sign be reviewed and approved by the Planning Board.

f. **Sidewalk Signs:** Can be used to enhance a tenant's identity but should not be considered as temporary signage. Restaurant menu boards are the best example of the appropriate use of sidewalk signs;

g. **Window Signs:** These signs are meant to establish or enhance a tenant's identity and should not be considered as temporary signage that advertises sales, promotions, etc.;

4. **Prohibited Sign Types:** The following sign types, components and devices are not permitted:

- Animated, moving, chaser, flashing, smoke, audible or odor-emitting signs;
- Boxed or cabinet type signs, except when totally recessed and integrated as part of the storefront;
- Fabric, Styrofoam, cardboard, paper or injected molded plastic;
- Luminous vacuum formed plastic letters;
- Exposed lamps and neon;
- Credit card decals, stickers and/or trademarks;

5. **Other Signage Requirements:**

- a. All signs erected in this Rehabilitation Area shall conform to the signage standards set forth as indicated in this document, and the uniform construction code;
- b. No sign shall be erected or altered within the Redevelopment Area without first obtaining approval from the appropriate review board and a permit from the Construction Official;
- c. A sign permit application shall include either structural drawings or specifications of how the sign is to be

- erected and electrical drawings if applicable of how the sign is to comply with the National Electric Code;
- d. All signs shall be designed, located, shielded and directed so as to prevent the casting of glare or direct light from artificial illumination upon streets, driveways and surrounding property;
 - e. Under no circumstances shall fluorescent or glowing paint be permitted for any signage in the Redevelopment Area;
 - g. The Planning Board at its discretion may waive some of the regulations if a proposed sign or light is presented as a site specific piece of civic art;
 - h. Freestanding billboard signs are expressly prohibited throughout the Redevelopment Area;
 - i. Street sign poles should match the style of the street light pole and should be finished black;

4

Circulation Plan

4.0 Circulation Overview:

1. **Background Information:**

- a. Through the Redevelopment Plan, the City of Hackensack has developed these guidelines that embrace a successful mixed use downtown through the design of a complete street network. A critical element to the future success of Main Street including the existing and future commercial development will be the conversion of the existing one-way street network into a two-way street network.
- b. The Redevelopment Plan recommends the city consider converting the existing one-way Main and State Streets into two-way streets in order to promote greater accessibility and viability for successful commercial and residential uses. The re-establishment of two-way circulation is based on developing a complete street design with an emphasis on accessibility for all modes of transportation in order to promote a successful mixed use residential and commercial core in the downtown.
- c. Main Street, State Street and River Street provide the roughly rectangular shape of the rehabilitation area. The conversion of both Main and State Street to two-way would increase the accessibility into and through the Rehabilitation Area.
- d. The Redevelopment Plan recommendations provide a more permeable street grid that supports vehicle, transit and pedestrian traffic. These recommendations provide for a re-imagined downtown which leverages the City's infrastructure, work-education centers and transportation options. This plan establishes preferred building mixes at a conceptual level.

2. **Circulation Plan Goals:**

- a. Promote and strengthen existing businesses with the creation of a livable, real and clearly defined downtown district made up of a series of interconnected, newly formed, mixed use neighborhoods;
- b. Promote the development of a place based environment where people live and work connected by great streets and activated by appropriate street retail, food and live entertainment uses;
- c. Promote a safer living, shopping and driving experience through the design of a hierarchy of streets, roads, gateways and boundaries which promote activity, vitality and safety;

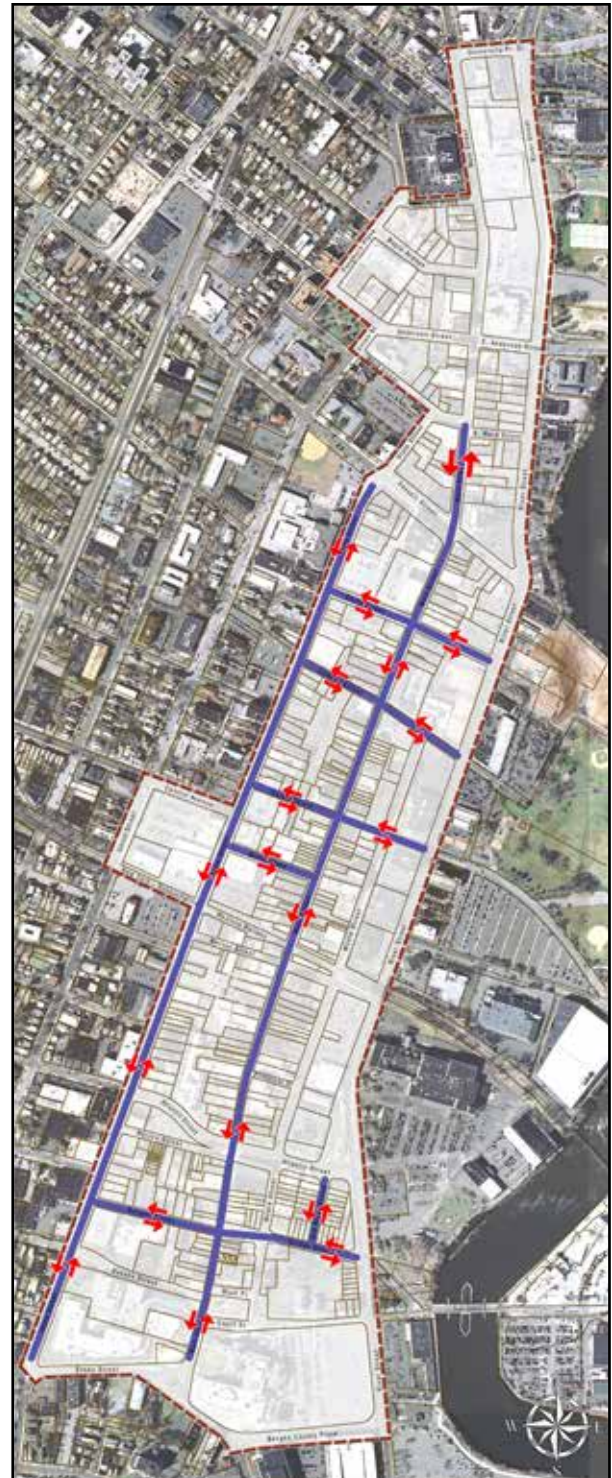

Figure 4.0 - Recommended two-way street network

- d. Promote improved pedestrian and vehicular connectivity into and through the Rehabilitation Area and to adjacent existing residential and commercial neighborhoods, as well as to transportation and transit options;
 - e. Promote the development of a compact urban environment with improved connectivity to the existing rail and bus transit to encourage walking and minimize vehicular dependency;
 - f. Promote and improve the efficiency and capacity of the existing street network to better accommodate vehicles, pedestrians and bicycles in the context of a complete street;
3. **Design Elements:** The following general design elements are the basis for recommending the conversion from a predominantly one-way to two-way system.
- a. The proposed conversion of all streets includes maintaining the existing face of curb to face of curb dimension. All street sections in the Redevelopment Plan include the existing street dimensions as well as recommendations for on-street parking;
 - b. The final design, layout and timing for the conversion of these streets will need to take into consideration the following design elements prior to construction;
 - Recommendations to provide pedestrian elements which meet current ADA standards;
 - Location and storage for bicycles;
 - Shuttle and bus stop routes, locations and design;
 - Parking garage locations and access;
 - The potential removal of existing street signalization;

4. **Conclusions / Recommendations:**

As indicated in the Traffic Study found in the Appendix the conversion to a two-way system analyzed the potential traffic impact of the conversion of Main Street, State Street and the secondary streets. The analysis included necessary changes to existing traffic control devices to support the conversion of State Street and Main Street, as well as the conversion of side streets to two-way traffic in support of these proposed initiatives.

The analysis indicates the proposed street network will be able to process existing development as well as future development allowed under the new zoning standards outlined in the Redevelopment Plan.

The operational key for Main Street will be to provide the following:

- a. Enforceable loading zones on Main Street;
- b. On-street parking as needed on both sides of the street;
- c. Coordination with mass-transit to remove buses and bus routes on Main Street;
- d. Do not permit semi-trucks on Main Street;
- e. Parking policies and rates that discourage all-day on-street employee parking;

The policy elements to consider include:

- a. A vision for how and why the community wants to complete its streets;
- b. The term “all users” includes pedestrians, bicyclists and transit passengers of all ages and abilities, as well as trucks, buses, and automobiles;
- c. Encourage street connectivity and aim to create a comprehensive, integrated, and connected network for

- all modes;
- d. Is adoptable by all agencies to cover all roads;
- e. Applies to both new and retrofit projects, including design, planning, maintenance and operations, for the entire right of way;
- f. Makes exceptions specific and sets a clear procedure that requires high-level approval of exceptions;
- g. Directs the use of the latest and best design criteria and guidelines while recognizing the need for flexibility in balancing user needs;
- h. Directs that complete streets' solutions will complement the context of the community;
- i. Establishes performance standards with measurable outcomes,

4.1 Street Sections:



Figure 4.1 - Main Street Typical Section: Court Street to Atlantic Street Typ

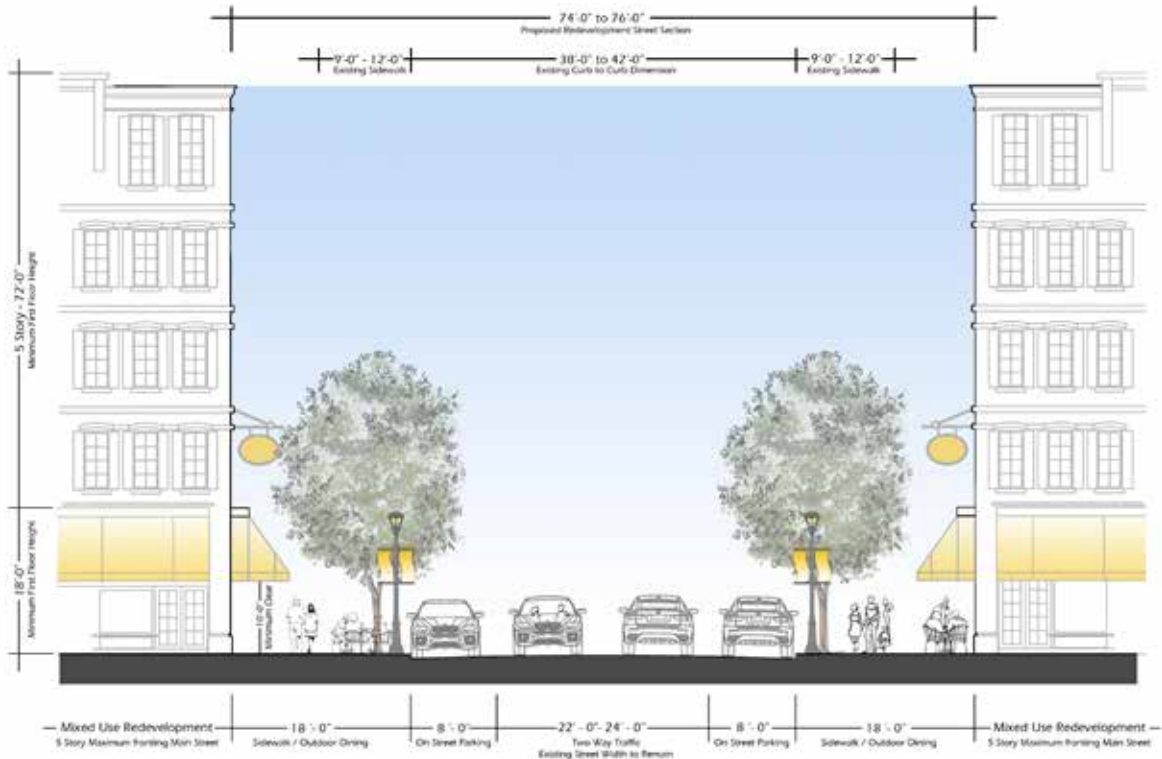

Figure 4.2 - Main Street Typical Section: Atlantic Street to University Plaza Drive Typ.

Main Street: Recommendation to convert Main Street from a one-way street with on-street parking on both sides to a two-way street with on-street parking on both sides. On-street parking spaces should have a dimension of at least 22' feet in length. Tandem on-street parking spaces are recommended on Main Street and require a minimum 6'-0" space between each set of spaces.

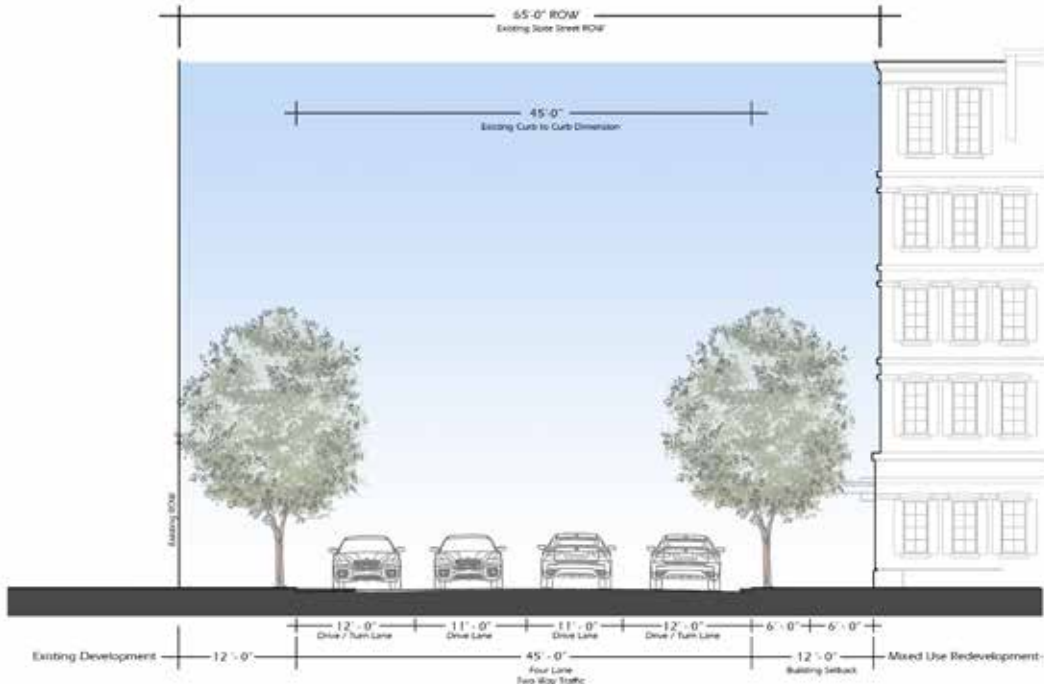

Figure 4.3 - State Street Typical Section: Essex Street to Passaic Street Typ.

State Street: Recommendation to convert State Street from a four lane, one-way street to a four lane two-way street. The existing face of curb to face of curb dimension will remain throughout the entire length of State Street. On street parking may remain in certain areas based on the existing conditions and proposed development. Turn lanes may be required at certain intersections to allow access to parking within the Rehabilitation Area and will be determined during the design phase.

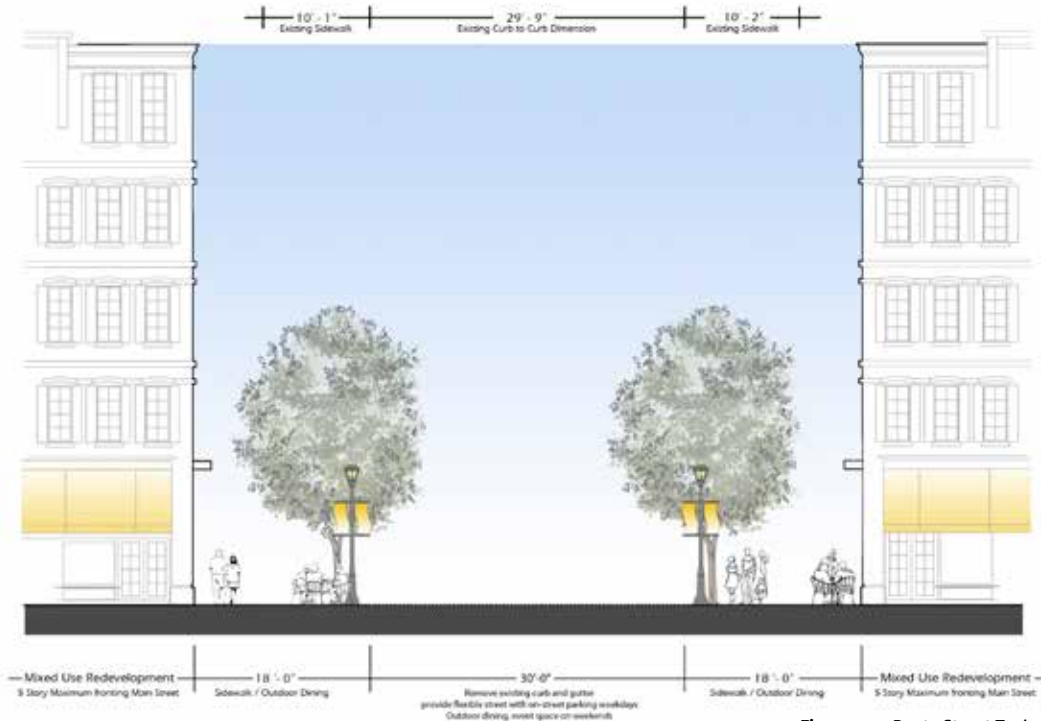

Figure 4.4 - Banta Street Typical Section

Banta Place: Recommendation to maintain Banta Street as a one lane, one-way street with parallel parking on both sides. Banta Place should be designed as a flexible outdoor space for events that can be closed during weekends with daytime and emergency access;

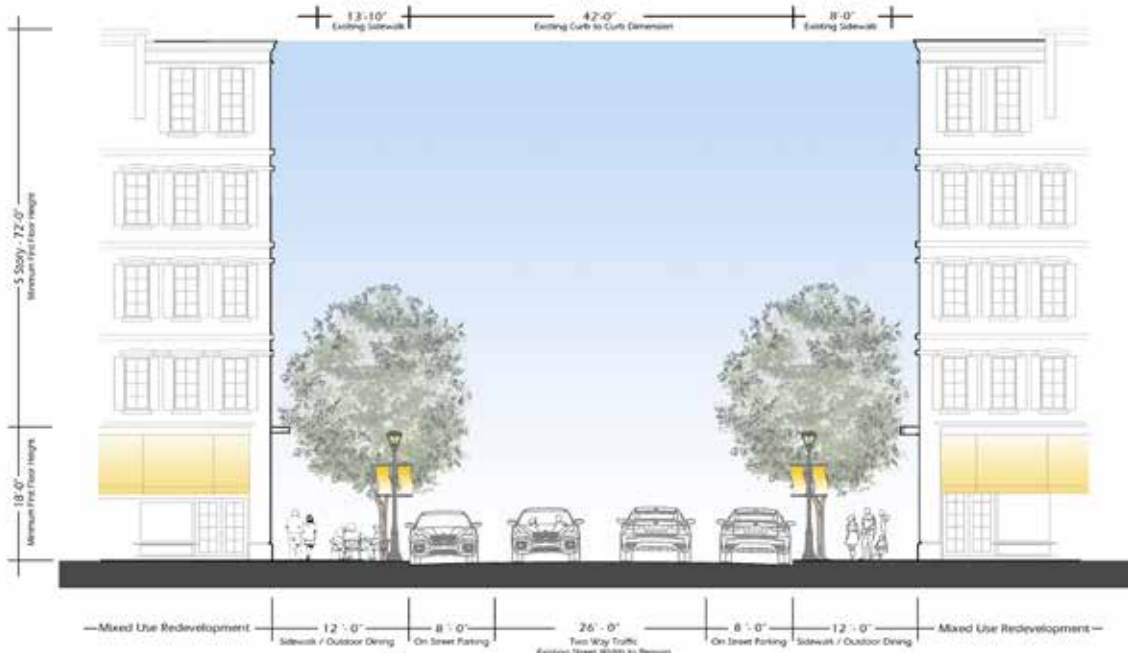

Figure 4.5 - East Mercer Street Typical Section



Figure 4.6 - West Mercer Street Typical Section

East and West Mercer Street: Recommendation to keep East and West Mercer Street as a two-way street in its current configuration.



Figure 4.7 - Salem Street Typical Section

Salem Street: Recommendation to convert Salem Street from a one-way, westbound street to a two-way street with the existing face of curb to face of curb dimension to remain in its current configuration.



Figure 4.8 - Bridge Street Typical Section

Bridge Street: Recommendation to maintain Bridge Street as a one-way westbound street.

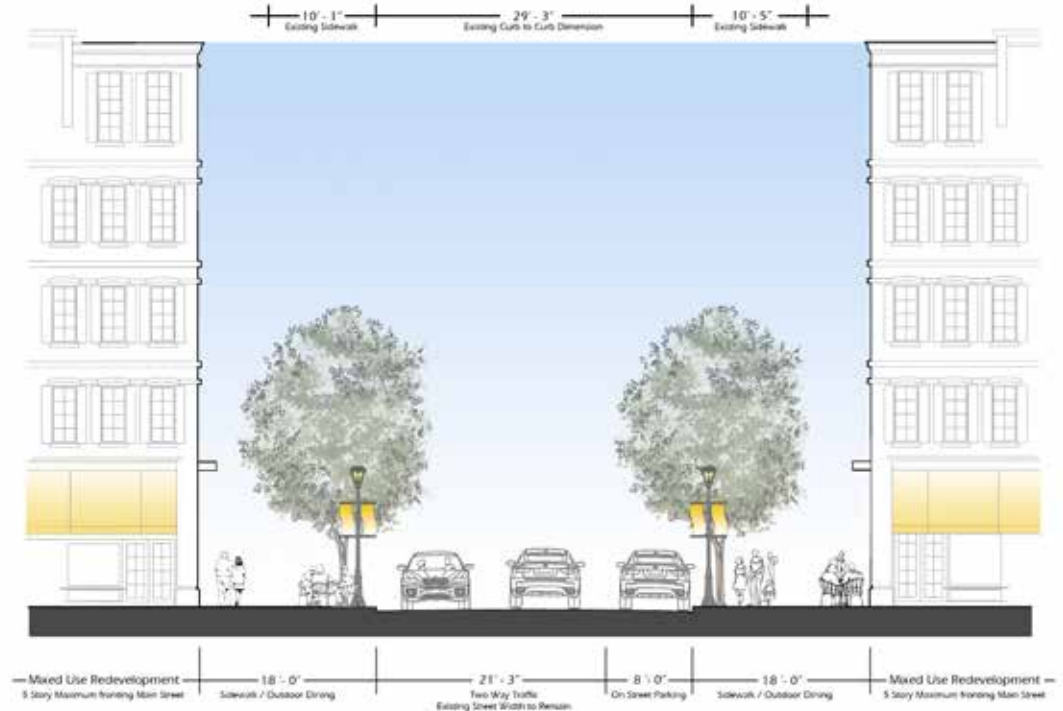

Figure 4.9 - East Berry Street Typical Section

East Berry Street: Recommendation to convert East Berry Street from a one-way westbound street to a two-way street and with a 12'-0" setback for new development. The existing face of curb to face of curb dimension to remain in its current configuration.



Figure 4.10 - West Berry Street Typical Section

West Berry Street: Recommendation to maintain West Berry Street as a two-way street with on street parking on both sides. A 12'-0" setback for new development with the existing face of curb to face of curb dimension to remain in its current configuration.

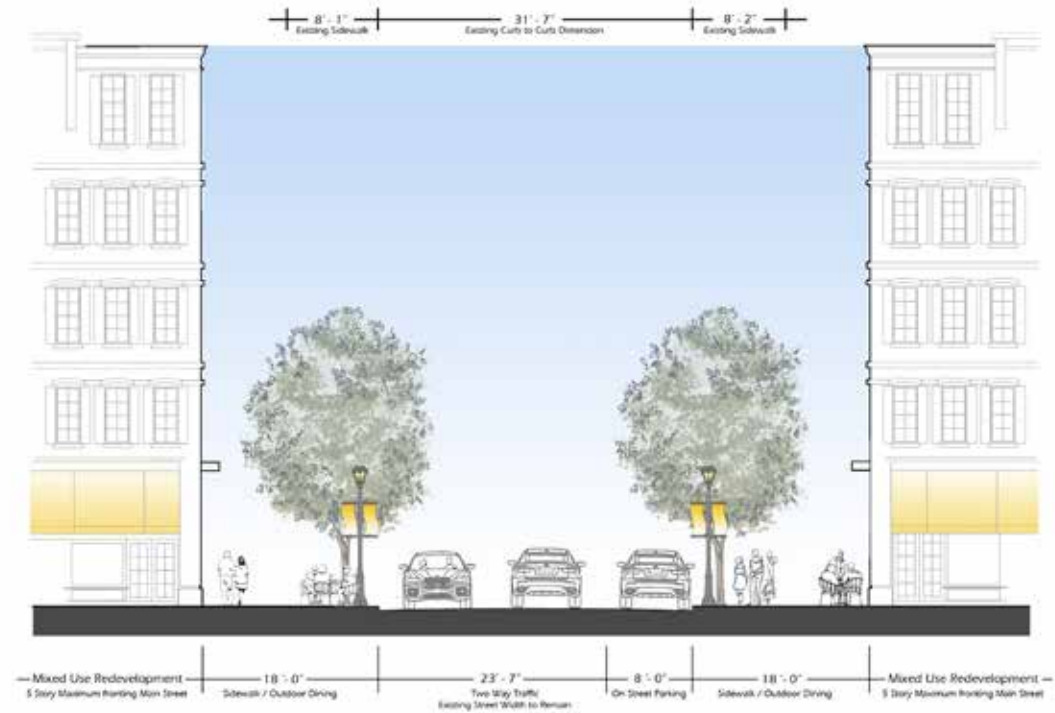

Figure 4.11 - East Camden Street Typical Section

East Camden Street: Recommendation to keep East Camden Street as a two-way street with on street parking on one side. The existing face of curb to face of curb dimension to remain in its current configuration.



Figure 4.12 - West Camden Street Typical Section

West Camden Street: Recommendation to convert West Camden Street from a one-way westbound street to a two-way street with the existing face of curb to face of curb dimension to remain in its current configuration.

5

Implementation Strategies

Section 5.0 – Implementation Strategies:

1. The purpose of this section is to outline implementation strategies and mechanisms the City of Hackensack may consider as next steps in order to support its commitment to the revitalization of its downtown.
2. The City of Hackensack may consider other implementation strategies to entice significant revitalization in the Rehabilitation Area.
 - a. Consideration to provide public improvements including but not limited to;
 - Infrastructure Improvements: Storm water and sanitary sewer upgrades and improvements;
 - Streetscape Improvements: Hardscape and softscape improvements including: street trees, street furniture, and street lighting;
 - Hardscape Improvements: Sidewalks, crosswalks and intersection improvements;
 - Gateways: Potential signage, monumentation and/or gateways into the downtown;
 - Parks and Open Space: Parks, open space and plazas associated with a project which are accessible to the public;
 - Parking Structures: Public parking structures that can be utilized by office, retail, civic and residential rental users;
 - b. Consideration of public private partnerships, including funding and/or financial mechanisms to encourage and support rehabilitation and development in the rehabilitation area;
 - c. Consideration for a streamlined submittal, review, and approval process for projects;
 - d. Consideration for a streamlined submittal, review, and approval process for projects;
 - e. Consideration for funding for open space and art;



Figure 5.0 - Conceptual Development Plan

Section 5.1 Rehabilitation Process:

The City Council or designated Redevelopment Entity may consider a competitive selection process through the issuance of an RFP or RFQ for the designation of a redeveloper(s) within the Rehabilitation Area. The determination to undertake a competitive selection process may be made at the sole discretion of the City Council or designated Redevelopment Entity from time to time to spur or foster Development Project(s) in the Rehabilitation Area as defined in Section 2.5 of this Redevelopment Plan.

In addition, owners of property in the Rehabilitation Area are encouraged to undertake the rehabilitation of their property in accordance with this Redevelopment Plan. Existing property owners are not required to be designated as a Redeveloper in order to rehabilitate their property in accordance with this Redevelopment Plan, but are required to be designated if they are redeveloping their property beyond what is identified in the Rehabilitation section of this plan.

Section 5.2 Financing / Funding Mechanisms:

In association with a Redevelopment Agreement, the City Council or designated Redevelopment Entity may consider creative financing mechanisms for Development Projects to promote revitalization in the Rehabilitation Area. Such mechanisms may consider utilizing any of the following as a means for the implementation of public improvements and/or paying of debt service on bonds, notes or other obligations related thereto as it pertains to a Development Project:

- a. **Special Assessment Financing:** The City Council may consider levying a special tax assessment on all or a portion of a Development Project pursuant to N.J.S.A. 40:56-1 et seq. in order to provide for the debt service on any such bonds, notes or other obligations;
- b. **Parking Revenue Financing:** The City Council or Redevelopment Entity may consider allocating revenues generated by public parking facilities in order to provide for the debt service on any such bonds, notes or other obligations;
- c. **Other Available Revenues:** The City Council or Redevelopment Entity may consider allocating other available revenues generated by a project in order to provide for the debt service on any such bonds, notes, or other obligations;
- d. **Development Rights / Inclusion of**



Figure 5.1 - Conceptual Redevelopment Plan - Sphere of Influence 1: Conceptual plan indicates a mixed use redevelopment opportunity with retail uses located on the first level along Main Street and medium to high density residential development for the remaining portions of the blocks. Public parking structures are located in the middle of each block with access through public plazas to Main Street. The conceptual redevelopment plan proposes approximately 1,500 to 1,800 residential units and 150,000 sf of retail.



Figure 5.2 - Conceptual Redevelopment Plan - Sphere of Influence 2: Conceptual plan indicates a mixed use redevelopment opportunity with an emphasis on civic, cultural and entertainment opportunities. Located along Banta Place the conceptual plan considers opportunities for outdoor festivals, street and music fairs and other entertainment venues. Entertainment and cultural venues represent the redevelopment opportunity which would support retail and restaurants throughout the downtown area.

Public Property: The City may consider including the sale of public owned property to the designated redeveloper(s) as a part of a development project;

- e. **Municipal Reimbursement Model:** The City Council may consider entering into an agreement with a designated redeveloper(s) whereby the designated redeveloper(s) would agree to initially finance and construct the public improvements as listed in this section associated with a Development Project. In turn, the City Council would consider bonding to purchase from, or otherwise reimburse the developer for the public improvements associated with the project upon completion, minimum occupancy requirements and/or other considerations based on a financial model and analysis;
- f. **Local, State and Federal Grants / Tax Credits:** The City Council or Redevelopment Entity may consider available federal, state and local programs, grants and tax credits to assist in the funding and implementation of public improvement projects within the Rehabilitation Area;

In addition, the City Council or Redevelopment Entity (to the extent allowed by law) may consider the following financial mechanisms:

- a. **Payment in Lieu of Taxes:** The City Council may consider granting a five-year tax abatement for all or a portion of a project pursuant to N.J.S.A. 40A:21-1 et seq. and the City's Tax Exemption and Abatement Ordinance;
- b. **Payment in Lieu of Parking:** The City Council or Redevelopment Entity may consider, in satisfaction of certain parking requirements, payments in lieu of building all of the parking for a particular project in order to fund off-site parking facilities;
- c. **Development Rights / Inclusion of Public Property:** The City Council or Redevelopment Entity may consider including the sale of City or Redevelopment Entity owned property to a redeveloper as a part of a project;

Any and all funding or financial mechanisms referred to herein are for informational and illustrative purposes only and may not be relied upon by any party or person as an offer, agreement or commitment by the City.

Any such mechanisms or incentives shall be subject to the terms and conditions of a Redevelopment Agreement with a designated redeveloper at the absolute and sole discretion of the City Council.

Section 5.3 Implementation of Redevelopment Plan:

This Redevelopment Plan shall be implemented by the governing body of the City of Hackensack acting as the redevelopment entity, or through a designated Redevelopment Entity selected by the City Council. It is the intent of the City



Figure 5.3 - Conceptual Redevelopment Plan - Sphere of Influence 3: Conceptual plan indicates a mixed use redevelopment opportunity with retail uses located on the first level along Main Street and medium to high density commercial and office development for the remaining portions of the blocks. Public parking structures are located in the middle of each block with access through public plazas to the Main Street retail. The conceptual redevelopment plan proposes approximately 950,000 sf of commercial and office space and 100,000 sf of retail.

Council that this Redevelopment Plan shall preserve and not limit the powers set forth in the Local Redevelopment and Housing Law (“LRHL”), N.J.S.A. 40A:12A-1 et seq., for the implementation of redevelopment plans and redevelopment projects in Rehabilitation Areas. For informational purposes, it is noted that pursuant to N.J.S.A. 40A:12A-3 the term “redevelopment entity” applies equally when used in connection with the undertaking of a project in an area in need of redevelopment or area in need of rehabilitation.

Section 5.4 Phasing:

The clearance, planning, conservation, development and rehabilitation of the Rehabilitation Area may be accomplished in one or more phases or sub-phases as determined by the City Council or designated Redevelopment Entity.

Section 5.5 Selection of One or More Redevelopers:

The City Council or Redevelopment Entity may select one or more redevelopers to undertake projects in the Rehabilitation Area. Prior to the designation of a redeveloper to undertake a project in the Rehabilitation Area, the City Council or Redevelopment Entity shall determine that the redeveloper possesses rights to the property to be developed, or a reasonable plan and time line for obtaining rights to the property to be developed, as well as the experience, financial capability, and technical expertise to undertake the proposed project in the Rehabilitation Area.

The redeveloper may demonstrate its experience, financial capability and technical expertise to the City Council or Redevelopment Entity by providing evidence of its prior experience in constructing projects of similar size or scope, or through evidence of the prior experience of its retained professionals and/or staff at executing projects of similar size or scope, through the provision of statements of net worth, annual financial reports or commitments from lenders, or demonstrated prior experience obtaining project financing for projects of similar size or scope, through the retention of knowledgeable, experienced professionals, such as architects, engineers, planners, attorneys and financial advisors that have experience with projects of similar size or scope.

The foregoing listing is provided by way of example and not as a limitation upon the inquiry that the City Council or Redevelopment Entity may choose to undertake to make a determination that the redeveloper possesses the experience, financial capability, and technical expertise to undertake and complete a project in the Rehabilitation Area.

Section 5.6 Negotiation of One or More Redevelopment Agreements:

In the event that the City Council or Redevelopment Entity selects one or more redevelopers to undertake projects in the Rehabilitation Area, it shall require the redeveloper to execute a Redevelopment Agreement. The Redevelopment Agreement shall comply with the requirements of the LRHL and other applicable laws. The City Council or Redevelopment Entity may negotiate and collect revenue from a redeveloper to defray the costs of the City or Redevelopment Entity.

Section 5.7 Pre-Application Review Committee Process and Requirements:

An applicant may request a pre-application conference with the Pre-Application Concept Review Committee prior to submitting a formal application to either the Planning Board or Zoning Board of Adjustments. The compliance review

shall consist of a review of relevant site plan application elements to enable the City Council or Redevelopment Entity to determine that the site plan application is consistent with the Redevelopment Plan, determine the impact on existing facilities, identify development opportunities and constraints, and provide input on general design. In addition, the committee will discuss any waivers or variances that may be necessary and aid the applicant in preparing its submittal to the Planning or Zoning Board. The informal review by the Pre-Application Committee shall not be binding upon the applicant, the Planning Board, Zoning Board, or any official participating, the purpose of the review is to expedite development in the City and reduce the applicant's design and development costs.

As provided under Section 5.1, existing property owners are not required to be designated as a Redeveloper in order to rehabilitate their property in accordance with the Plan, but are still subject to a compliance review by the City Council or designated redevelopment entity to ensure compliance with the Redevelopment Plan. A Redeveloper designation and Agreement, however, may be required if an existing property owner seeks to secure any funding mechanisms or financial incentives that may be offered by the City pursuant to Section 5.2

Section 5.8 Additional Submission Requirements:

In addition the mentioned requirements for site plan applications the Applicant should also include the following analysis and studies pertaining to the project.

1. **Preliminary Fiscal Impact Analysis** (required where the redeveloper is seeking a financial incentive): This analysis should assess the fiscal impacts associated with the proposed development in the City of Hackensack. It should include the existing ratable base, existing tax revenues generated by the subject property, projected tax revenues generated by the subject property, projected residents and school age population, municipal and school district cost projects and projected fiscal impact;
2. **Traffic Impact Analysis:** The analysis should forecast additional traffic associated with the entire project, determine vehicular and pedestrian improvements necessary to accommodate the proposed development to help ensure safe and reasonable traffic conditions and reduce negative impacts created by the development;
3. **Massing and Shade Analysis:** A shadow study should be provided by the developer to determine if the building negatively impacts any adjacent properties;
4. **Environmental / Sustainable Analysis:** A preliminary environmental and sustainable analysis on the existing property and the impacts the project may have on the environment.

Section 5.9 Affordable Housing:

One of the City of Hackensack's objective's is to provide adequate and affordable housing, economic opportunity and a suitable living environment free from discrimination and an atmosphere that promotes educational growth and family stability. The City through its Housing Authority has established the following goals:

- a. To be the best property owner in the City of Hackensack;
- b. To provide an environment of hope and opportunity to its family residents in their quest to self-actualize;
- c. To utilize it resources in economical and efficient manner in meeting its goals and objectives;

- d. To provide the necessary services to allow its capable family residents to move to private market housing;
- e. To provide services to the elderly and disabled that allows them to remain in their independent living environment for as long as humanly possible;
- f. To ensure that all residents reside in a safe and secure environment;

The City believes that providing an adequate supply of quality affordable housing is essential. In order to support these efforts, the City of Hackensack requires all development either provide a set-aside of at least 10% of the total number of residential units as very-low-, low-, and moderate-income affordable housing units as a part of the project, or if a redeveloper can demonstrate to the City that any affordable housing set-aside would render the project financially infeasible, pay the required residential and/or non-residential development fee contribute to the City's Affordable Trust Fund as required in accordance with Chapter 45A-26 and A-27 to assist in the City's continuing commitment to building affordable units.

Inclusionary affordable housing units shall comply with the City's Affordable Housing Ordinance, Chapter 45A-1 through -22, Council on Affordable Housing Regulations, N.J.A.C. 5:93, and Uniform Housing Affordability Controls, N.J.A.C. 5:80-26.1, et. seq., and the New Jersey Fair Housing Act, N.J.S.A. 52:27D-301, et. seq.

6

Appendix

the use of infrastructure needs assessments and life-cycle costing. Provide adequate public facilities in ways that are consistent with the State Plan's vision and goals."

- f. "Provide Adequate Housing at a Reasonable Cost – Provide adequate housing at a reasonable cost through public/private partnerships that create and maintain a broad choice of attractive, affordable, ecologically designed housing, particularly for those most in need. Create and maintain housing in the Metropolitan and Suburban Planning Areas and in Centers in the Fringe, Rural and Environmentally Sensitive Planning Areas, at densities which support transit and reduce commuting time and costs, and at locations easily accessible, preferably on foot, to employment, retail, services, cultural, civic and recreational opportunities. Support regional and community-based housing initiatives and remove unnecessary regulatory and financial barriers to the delivery of housing at appropriate locations."
- g. "Preserve and Enhance Areas with Historic, Cultural, Scenic Open Space, and Recreational Value – Preserve, enhance, and use historic, cultural, scenic and recreational assets by collaborative planning, design, investment and management techniques. Locate and design development and redevelopment and supporting infrastructure to improve access to and protect these sites. Support the important role of the arts in contributing to community life, civic beauty and redevelopment in ways that are consistent with the State Plan's vision and goals."
- h. "Ensure Sound, Coordinated and Integrated Statewide Planning – Ensure sound, coordinated and integrated statewide planning by using the State Plan as a guide to planning and growth related decisions at all levels of government in ways that are consistent with the State Plan's vision and goals."
- i. "Increase Energy Efficiencies and Reduce Greenhouse Gas Emissions – Increase Energy Efficiencies and Reduce Greenhouse Gas Emissions by promoting the improved coordination and integration of transportation planning and land-use planning and decision-making to reduce vehicle miles traveled (VMT); and by the citing, development, design and use of green-building construction materials and techniques in ways that are consistent with the State Plan's vision and goals."

2. The State Planning Act (N.J.S.A. 52:18A-196 et. seq.) states:

- a. "Among the goals of the act is the following: ... conserve its natural resources, revitalize its urban centers, protect the quality of its environment, and provide needed housing and adequate public services at a reasonable cost while promoting beneficial economic growth, development and renewal."
- b. "It is in the public interest to encourage development, redevelopment and economic growth in locations that are well situated with respect to present or anticipated public services and facilities, giving appropriate priority to the redevelopment, repair, rehabilitation or replacement of existing facilities and to discourage development where it may impair or destroy natural resources or environmental qualities that are vital to the health and well-being of the present and future citizens of this state." (N.J.S.A. 52:18A-196 (d))

3. The State Plan Policy Map (SPPM)

- a. Recognizes that New Jersey requires different approaches in its Metropolitan, Suburban, Rural and Environmentally Sensitive Planning Areas. The New Jersey State Development and Redevelopment Plan adopted by the State Planning Commission, places the City of Hackensack in Planning Area 1 - the Metropolitan Planning Area and states:
- b. "The Metropolitan Planning Area – This Planning Area includes a variety of municipalities that range from

large Urban Centers to 19th century towns shaped by commuter rail and post-war suburbs. The Communities in this Planning Area have strong ties to major metropolitan centers – New York/Newark/Jersey City metropolitan region; the Philadelphia/Camden/Trenton Metropolitan Region; and on a smaller scale the Easton/Phillipsburg Metropolitan Region.”

- c. “These municipalities have many things in common: mature settlement patterns; infrastructure systems that are approaching their reasonable life expectancy; an aging housing stock in need of rehabilitation; recognition that redevelopment will be the predominant form of growth; and a growing realization of the need to regionalize services and systems. In addition, the wide and often affordable choice of housing in proximity to New York and Philadelphia has attracted significant immigration, resulting in noticeable changes in demographic characteristics overtime.”
- d. “In the Metropolitan Planning Area, the State Plan’s intent is to do the following:”
 - “Provide for much of the State’s future development and redevelopment;”
 - “Revitalize Cities and Towns;”
 - “Take advantage of increased densities and compact building design;”
 - “Encourage distinctive, attractive neighborhoods with a strong sense of place;”
 - “Provide for mixed-use concentrations of residential and commercial activity;”
 - “Create a wide range of residential housing opportunities and choices with income mix;”
 - “Provide for a variety of multi-modal transportation alternatives;”
 - “Prioritize clean-up and redevelopment of brownfields and greyfields sites;”
 - “Create cultural centers of state-wide significance;”
 - “Re-design any existing areas of low-density sprawl;”

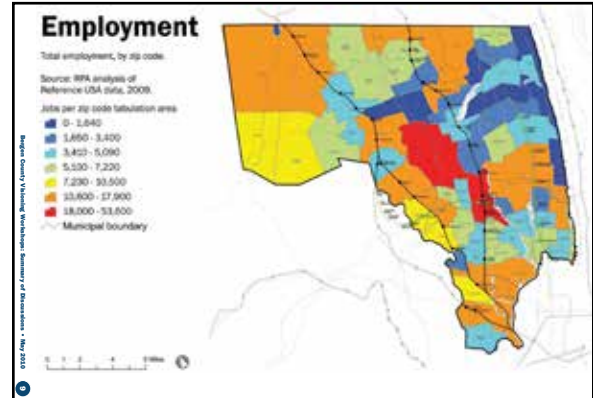

Draft Bergen County Master Plan
Employment Data

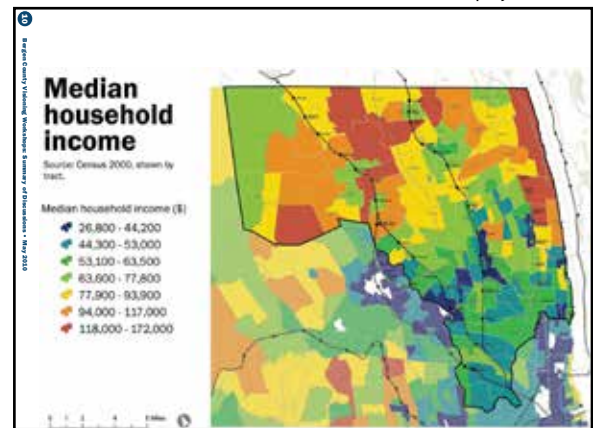

Draft Bergen County Master Plan
Medium Household Income

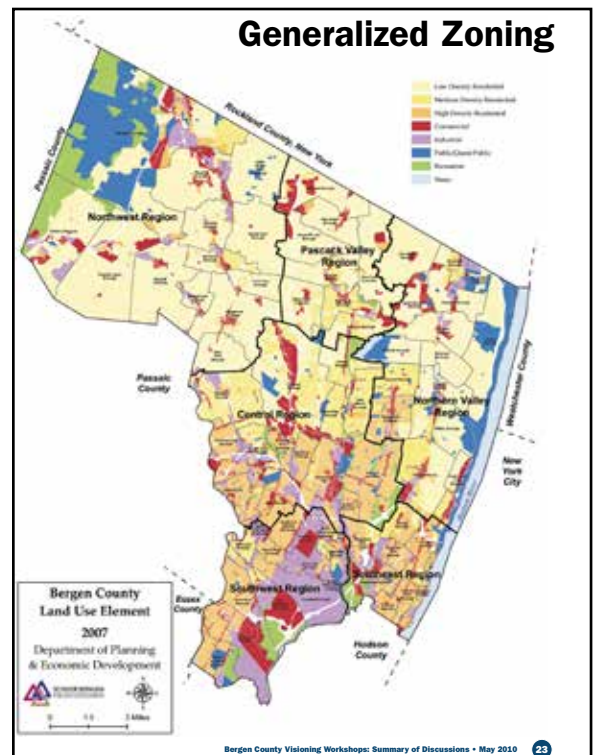

Draft Bergen County Master Plan
General Zoning

II. Bergen County Master Plan:

In reviewing the Final Draft Bergen County Master Plan the following information pertains to goals and policies for a program of rehabilitation which discuss the development and redevelopment policies for urban areas.

1. Bergen County Master Plan Overview:

- a. "The Bergen County Department of Planning and Economic Development is undertaking a county-wide planning effort that will result in the first County Master Plan in some time."
- b. "The Master Plan will create a unifying vision for the County's 70 municipalities and help them plan for sustainable growth while protecting environmental resources. Development of the Master Plan will be a collaborative process involving the County, municipalities, regional agencies, public and private sector stakeholders and Bergen County citizens."

2. Draft Report

- a. The Draft Report provided on the Bergen County Master Plan website includes the following descriptions:
 - "Future growth will primarily occur through redevelopment and infill;"
 - "Redevelopment provides opportunities to create new public spaces and green areas in places that have none;"
 - "Redevelopment on a large scale using green guidelines has the potential over time to significantly ameliorate many of the county's storm water run-off and water quality issues;"
 - "Redevelopment can occur spontaneously and be privately driven, or it can take place as a result of a public initiative, usually under the jurisdiction of a local redevelopment agency;"

III. City of Hackensack 2001 Master Plan Study, 2009 Master Plan Reexamination Report:

The City's Master Plan report provided strategies for redevelopment in the Study Area, which included developing the downtown based on spheres of influence. The spheres of influence are depicted in Exhibit 'E' in the Appendix. The Redevelopment Plan is consistent with the Master Plan report as noted in the following:

1. Goals and Objectives stated in the Master Plan Reports excerpts include:

- a. "Maintain and enhance the quality of established neighborhoods in Hackensack and promote compatibility of new development with existing or specifically defined character;"
- b. "Encourage public and private redevelopment to assist in the rehabilitation of areas in need of improvement and upgrading including utilization of State and Federal Assistance programs, where applicable, as well as public / private partnerships;"



Exhibit 'E' - 2001 Master Plan - Spheres of Influence
Kasler Associates, PA

- c. “Provide housing opportunities and a variety of housing for various income levels of the population, including low and moderate income housing, middle income housing and senior citizen housing; encourage multi-family and mixed-use development and redevelopment within the central business district
- d. “Improve the quantity, quality and availability of parks and open space including active and passive recreational facilities, neighborhood parks and environmentally sensitive areas. Encourage open space within major new developments and redevelopment. Promote the establishment of a publicly accessible linear greenway (riverside) park along the Hackensack River;”
- e. “Encourage adaptive re-use of historic and character defining structures, where appropriate; encourage context sensitive design of replacement structures;”
- f. “Promote adequate community services for all portions of Hackensack with an emphasis on improving the quality and adequacy of education, stormwater drainage, sewer, transportation, parking and recreation facilities;”
- g. “Promote and upgrade the downtown area of Hackensack including the four spheres of influence with an emphasis on assuring a vibrant, mixed use and appealing downtown;”

2. Strategies for Redevelopment:

In the City’s Master Plan the report provides strategies for redevelopment in the Study Area which include developing the downtown based on spheres of influence. These include:

- a. “Main Street is too long to be developed continuously, and thus must be developed in “spheres of influence”; the government sector, the banking / educational / cultural sphere containing the urban node, the retail sector which would focus on conventional and household shopping and the Packard area
- b. “The downtown study should focus on the following:”
 - “The potential for redevelopment of the Main Street Area;”
 - “A reduction in the scale of the retail/shopping sector. Main Street is too long to be developed continuously. The downtown area is not pedestrian friendly;”
 - “The provision of additional parking and the dichotomy between long term (monthly) parking and short term shopper parking needs to be resolved;”
 - “The ERA report believes that (mid-rise) apartment uses which can overlook the Hackensack River in the downtown are potentially marketable and can provide an alternative market for goods and services in the downtown corridor.”

3. The City’s 2009 Master Plan Re-examination Report

Contains a significant amount of narrative related to areas in need of rehabilitation which included the following:

- a. Regarding Areas in Need of Rehabilitation the document states: “A viable alternative to the use of eminent domain is available to the City for stimulating private redevelopment in the form of Areas in Need of Rehabilitation. This simpler approach to side-scale rehabilitation and redevelopment does not involve eminent domain, but it provides a means for making substantial progress at minimal cost.”
- b. Regarding the program of Rehabilitation the document states: “In addition, the Mayor and Council must determine that a program of rehabilitation, as defined in the LRHL, may be expected to prevent further deterioration and promote the overall development of the community.”
- c. Regarding Infrastructure Age the document states: “While the City’s housing stock as of the 2000 US Census indicated that 45% was built before 1960, it is probable that more discreet, yet fairly extensive areas

of the City would qualify under the age of housing criteria. The age of water and sewer infrastructure may also qualify designation of the entire city as an area in need of rehabilitation.”

- d. Regarding Rehabilitation Area Options the document states: “The City’s options for redevelopment in an area in need of rehabilitation are basically the same as for an area in need of redevelopment, except that eminent domain cannot be used unless a formal designation of one or more properties as an area in need of redevelopment is made by the Mayor and Council. Thus, proceeding with the rehabilitation route does not preclude pursuing special properties for designation as an area in need of redevelopment if needed later on. In addition, the rehabilitation designation requires a simple resolution (no public hearing or special notice required) by the Mayor and Council, thus avoiding the time and expense of a redevelopment designation study.”
- e. The document also states: “The available options for an area designated as an area in need of rehabilitation include the following:”
 - “Planning for redevelopment in a collaborative process with property owners, rather than an adversarial one, resulting in a shorter path to actual re-investment in the designated area.”
 - “Property owners can be afforded tax abatement over five years to allow their capital to be directed to property upgrades and expansions, which ultimately enhance the tax base due to the positive effects on the subject property and those around it.”
 - “The City may prepare a redevelopment plan for any area designated for rehabilitation, select a redeveloper, provide special redevelopment zoning standards and design criteria and phase the development over a predetermined schedule.”
 - “Off-site improvements can be accomplished without the need for meeting the “rational nexus” criteria.”
 - “Each project can be guided by a redeveloper’s agreement or simply the requirements of the redevelopment plan.”

4. Regarding the Rehabilitation Approach the document states:

“The area in Need of Rehabilitation approach has been effectively used in number of New Jersey Municipalities and holds great promise for the City of Hackensack. Therefore this report strongly recommends the pursuit of this approach in all areas of the City that meet the criteria.”

IV. City of Hackensack 2020 Master Plan Reexamination Report:

The City’s 2020 Master Plan Reexamination Report provided further strategies for redevelopment in the Study Area, which included developing the downtown. The Redevelopment Plan is consistent with the Master Plan report as noted in the following:

1. The Plan which was adopted in 2012 and amended as recently as 2017 promotes:
 - a. Smart growth principles by creating zoning which increases development flexibility, reduces parking ratios and promotes mixed-use, pedestrian friendly development in the downtown;
 - b. Connectivity to existing public infrastructure, including the two NJ Transit Rail Stations, the NJ Transit Regional Bus Station and Routes 4, 17, 46, Interstate 80 and the Garden State Parkway;
 - c. A mixture of uses with a variety of residential housing options to encourage walkability and active streetscapes;
 - d. Redevelopment and rehabilitation through architectural, neighborhood design standards that ensure high

quality development;

- e. The implementation of a two way street system; and
- f. Strategies which include municipal tools and mechanisms to promote revitalization;

1. Goals and Objectives stated in the Master Plan Reports excerpts include:

- a. Zoning and Land Use: Recommendations for changes to the current Zoning and Land Use patterns for the City to ensure growth and compliment the existing neighborhoods.
- b. Streamline & Modernize the Zoning Ordinance: Recommendations for changes to the existing Zoning Ordinance to establish clear and concise requirements.
- c. Downtown Revitalization: Strategies and recommendations to further advance the revitalization efforts within the downtown.
- h. Economic Development: Recommendations for expansion of market sectors as well as growth to the existing tax base in order to move toward economic sustainability.
- k. Housing: Recommendations to ensure a variety of housing types including Senior, Disabled, Veteran and Affordable housing in the future.

2. The specific Goals and Objectives stated in the Master Plan Reports for the Downtown include the following:

- a. 2012 Downtown Redevelopment Initiatives:
 - i. Promote the continued redevelopment of the downtown as a pedestrian friendly mixed use environment with the following:
 - Storm and sanitary sewer separation throughout the entire City including the Downtown Area;
 - Completion to the circulation improvements identified in the 2012 Downtown Master Plan including the conversion of Main Street to two way;
- c. Public Private Partnerships / Opportunity Zone Funding:
 - i. The City should continue to leverage municipally owned land for the purposes of implementing the City's redevelopment goals with public private partnerships (PPPs) including the City's surface parking lots that have been previous designated as areas in need of redevelopment.
- e. Downtown Student Housing: Considering the concentration of post-secondary academic institutions in Hackensack, the City should explore ways to encourage developers to create housing within the downtown that is affordable to students.
- f. Hotel / Extended Stay: The City should continue to look for opportunities to promote a hotel either in the downtown or associated with Hackensack Meridian Health or the proposed STEM Zone. This use would not only support the existing hospital, but would provide additional activity and nightlife in the downtown area with the growing performing and cultural arts uses.
- g. Gateways: The City should identify the "gateways" to its Downtown (the principal points of entry) and celebrate those gateways with monuments such as arches, art, and conspicuous signage that welcomes visitors and makes the district more identifiable.
- h. Liquor Licenses: The City should continue to advocate for liquor license reforms that would increase the number of liquor licenses available in the City. This would help the City establish itself as a night-life destination.

IV. Neighboring Community Master Plans:

Information for the Master Plans of the adjacent municipalities have been included as stated in the 2009 Master Plan Reexamination Report which includes the following information:

1. Borough of Bogota: “The 2003 Master Plan for Bogota recommends a rezoning of properties located in the Planned Development zone. This zone directly abuts the City’s southeast boundary. The planned development zone has existed since the last master plan was adopted and no planned development has occurred on these parcels for the past ten years. Currently, these properties contain a driving range and have been there for a long time. The Borough’s master plan therefore recommends that this area be zoned for 1-2 zones, which permits light-industry use, warehouses, and offices, indoor and outdoor recreational use.”
2. Borough of Hasbrouck Heights: “The 2003 Master Plan Reexamination Report recommends that the Borough should consider redeveloping portions of lands along Route 17, which connects Hasbrouck Heights to Hackensack City. However, these projects, if and when they are built, will not significantly impact Hackensack.”
3. Borough of Little Ferry: “The Borough’s 2004 Master Plan Reexamination Report recommends significant redevelopment along the waterfront. The plan recommends developing the area around Bergen Turnpike and Valley Road intersection that currently contains an underutilized shopping center to be redeveloped to include hotel, high-end large retail anchors, restaurants and a mix of offices. The plan recommends redevelopment along the waterfront that would include low-rise (1-3 story) mixed-use development with an array of recreational amenities and pedestrian walkways along the riverfront. The recommended projects are consistent with the development currently occurring along River Street in Hackensack.”
4. Borough of Lodi: “The Borough of Lodi’s 2010 Master Plan Reexamination Report” does not have any significant plans to areas that border Hackensack which would affect Hackensack.
5. Borough of Maywood: “The Borough of Maywood 2003 Master Plan recommends that redevelopment study should be undertaken for areas along the southwesterly side of the Borough that have access from Route 17. This, however, will not impact Hackensack.”
6. Borough of Paramus: “The 2005 Master Plan Reexamination Report recommends that the Borough should evaluate for any areas in need of redevelopment within the Borough. The Plan also suggests rezoning certain residential properties that directly abut the Maywood Borough boundary. However, this will not impact Hackensack.”
7. Borough of River Edge: “The Borough does not have any significant plans that would affect Hackensack.”
8. Borough of South Hackensack: “The Borough prepared a land use element of the Master Plan in 2001; however, no changes are proposed at this time.”
9. Borough of Teterboro: “The 2006 Master Plan Reexamination Report recommends that the Borough should evaluate potential properties within the existing industrial area that are in need of redevelopment.”
10. Township of Teaneck: “The Township recently adopted its Master Plan, April 2, 2007. The plan recommends that some properties located centrally within the Township be rezoned. However, the proposed zone changes will not impact the City of Hackensack.”

11. Village of Ridgefield Park: “Portions of the industrial area that abut the Hackensack boundary to the east are being redeveloped. As part of the riverside park system plan, a new bike path is proposed along the river. These improvements are consistent with the waterfront redevelopment projects that Hackensack and Bergen County are proposing.”

Area in Need of Rehabilitation Lot and Block Numbers
 Information obtained through the Bergen County GIS website

PAM Pin	Block	Lot	Address
Block 64	Block	Lot	Address
0223-64-1	64	1	15 Court Street
Block 200	Block	Lot	Address
0223-200-1	200	1	Null
Block 202	Block	Lot	Address
0223-202-1	202	1	20-22 Court Street
0223-202-3	202	3	21 Bridge Street
0223-202-8	202	8	42 Court Street
0223-202-9	202	9	63 River Street
0223-202-10	202	10	Null
0223-202-11	202	11	Null
0223-202-12	202	12	Null
0223-202-13	202	13	Null
0223-202-14	202	14	Null
0223-202-15	202	15	60 Court Street
0223-202-17	202	17	Null
0223-202-18	202	18	Null
0223-202-19	202	19	Null
Block 203	Block	Lot	Address
0223-203-8	203	8	38 Bridge Street
0223-203-9	203	9	Null
0223-203-17	203	17	127 River Street
Block 204	Block	Lot	Address
0223-204-1	204	1	30 Bridge Street
0223-204-2	204	2	Null
0223-204-3	204	3	26 Bridge Street
0223-204-4	204	4	Null
0223-204-10	204	10	82-84 Moore Street
0223-204-11	204	11	88 Moore Street
0223-204-12	204	12	Null
0223-204-13	204	13	Null
0223-204-14	204	14	Null
0223-204-15	204	15	Null
0223-204-16	204	16	Null
0223-204-17	204	17	Null
0223-204-18	204	18	Null
0223-204-19	204	19	Null
0223-204-20	204	20	87 Old River Street
0223-204-21	204	21	Null
0223-204-22	204	22	Null
0223-204-23	204	23	81 Old River Street
0223-204-23.01	204	23.01	Null
Block 204.01	Block	Lot	Address
0223-204.01-16	204.01	16	111 River Street
0223-204.01-26.01	204.01	26.01	108-110 Moore Street
Block 205	Block	Lot	Address
0223-205-1	205	1	14 Washington Place
0223-205-2.01	205	2.01	54 Main Street
0223-205-3	205	3	
Block 206.01	Block	Lot	Address
0223-206.01-5	206.01	5	85 Moore Street
0223-206.01-6	206.01	6	83 Moore Street

0223-206.01-8	206.01	8	75 Moore Street
0223-206.01-9	206.01	9	78 Moore Street
0223-206.01-10	206.01	10	Null
0223-206.01-12	206.01	12	Null
0223-206.01-14	206.01	14	82 Main Street
0223-206.01-15	206.01	15	84 Main Street
0223-206.01-16	206.01	16	90 Main Street
Block 206.02	Block	Lot	Address
0223-206.02-21	206.02	21	106-108 Main Street
0223-206.02-22	206.02	22	112-114 Main Street
0223-206.02-23	206.02	23	Null
0223-206.02-24	206.02	24	116-122 Main Street
0223-206.02-25	206.02	25	124 Main Street
0223-206.02-26	206.02	26	126-130 Main Street
0223-206.02-26.01	206.02	26.01	111 Moore Street
Block 207	Block	Lot	Address
0223-207-2	207	2	15 Main Street
0223-207-3	207	3	21 Main Street
0223-207-4	207	4	25 Main Street
0223-207-5	207	5	19 Main Street
Block 208	Block	Lot	Address
0223-208-23	208	23	15 Bergen Street
0223-208-24	208	24	63 Main Street
0223-208-25	208	25	61 Main Street
0223-208-26	208	26	59 Main Street
0223-208-27	208	27	57 Main Street
0223-208-28.01	208	28.01	53-55 Main Street
0223-208-28.02	208	28.02	51 Main Street
0223-208-29	208	29	47 Main Street
0223-208-30	208	30	41-43 Main Street
0223-208-31	208	31	60 State Street
Block 209	Block	Lot	Address
0223-209-1	209	1	14-18 Bergen Street
0223-209-2	209	2	Null
0223-209-3	209	3	24 Bergen Street
0223-209-4	209	4	Null
0223-209-7	209	7	36 Bergen Street
0223-209-16	209	16	
0223-209-17	209	17	15 Warren Street
0223-209-18	209	18	Null
0223-209-19	209	19	Null
0223-209-20	209	20	85 Main Street
0223-209-21	209	21	11 Atlantic Street
0223-209-22	209	22	9 Atlantic Street
0223-209-23.01	209	23.01	1 Atlantic Street
0223-209-23.02	209	23.02	5 Atlantic Street
0223-209-24	209	24	89-91 Main Street
0223-209-27	209	27	79-81 Main Street
0223-209-28	209	28	73-77 Main Street
0223-209-29	209	29	71 Main Street
0223-209-30	209	30	67-69 Main Street
Block 210.01	Block	Lot	Address
0223-210.01-1	210.01	1	20 Atlantic Street
0223-210.01-12	210.01	12	120 State Street

Area in Need of Rehabilitation Lot and Block Numbers

0223-210.01-13	210.01	13	126 State Street
0223-210.01-14	210.01	14	Null
0223-210.01-15	210.01	15	136 State Street
0223-210.01-16	210.01	16	Null
0223-210.01-17.02	210.01	17.02	135 Main Street
0223-210.01-18	210.01	18	131 Main Street
0223-210.01-19	210.01	19	127 Main Street
0223-210.01-20	210.01	20	125 Main Street
0223-210.01-21	210.01	21	121 Main Street
0223-210.01-22	210.01	22	Null
0223-210.01-23	210.01	23	111-113 Main Street
0223-210.01-24	210.01	24	109 Main Street
0223-210.01-25	210.01	25	105 Main Street
Block 210.02	Block	Lot	Address
0223-210.02-2	210.02	2	Null
0223-210.02-8	210.02	8	104 State Street
Block 303	Block	Lot	Address
0223-303-1	303	1	140 State Street
0223-303-2	303	2	Null
0223-303-3	303	3	146 State Street
0223-303-4	303	4	Null
0223-303-5	303	5	150 State Street
0223-303-6	303	6	154 State Street
0223-303-7	303	7	Null
0223-303-9	303	9	170 State Street
0223-303-10	303	10	162-174 State Street
0223-303-11	303	11	27-35 Mercer Street
0223-303-13	303	13	21 Mercer Street
0223-303-15	303	15	171-173 Main Street
0223-303-16	303	16	Null
0223-303-17	303	17	Null
0223-303-18	303	18	157 Main Street
0223-303-19	303	19	153-155 Main Street
0223-303-20	303	20	149 Main Street
0223-303-21	303	21	145 Main Street
0223-303-22	303	22	141 Main Street
0223-303-22.02	303	22.02	139 Main Street
0223-303-22.03	303	22.03	137 1/2 Main Street
0223-303-22.04	303	22.04	137 1/2 Main Street
Block 304	Block	Lot	Address
0223-304-1.01	304	1.01	179 Main Street
0223-304-1.02	304	1.02	10 Mercer Street
0223-304-2	304	2	Null
0223-304-5	304	5	32 Mercer Street
Block 309	Block	Lot	Address
0223-309-1	309	1	25 Salem Street
0223-309-3	309	3	190 Moore Street
Block 310	Block	Lot	Address
0223-310-1	310	1	250 Moore Street
Block 311	Block	Lot	Address
0223-311-1.01	311	1.01	184 Main Street
0223-311-2	311	2	186 Main Street
0223-311-3	311	3	190 Main Street
0223-311-8.01	311	8.01	192 1/2 Main Street

0223-311-8.02	311	8.02	194 Main Street
0223-311-10	311	10	198 Main Street
0223-311-11	311	11	204 Main Street
0223-311-12	311	12	Null
0223-311-13	311	13	206 Main Street
0223-311-17	311	17	216-218 Main Street
0223-311-17.01	311	17.01	Null
0223-311-18	311	18	223 Moore Street
0223-311-19.01	311	19.01	224 Main Street
0223-311-19.02	311	19.02	222 Main Street
0223-311-20.01	311	20.01	228 Main Street
0223-311-20.02	311	20.02	226 Main Street
0223-311-22	311	22	230-238 Main Street
0223-311-24	311	24	235 Moore Street
0223-311-25	311	25	Null
0223-311-26	311	26	Null
0223-311-38.01	311	38.01	Null
0223-311-45	311	45	185 Moore Street
Block 311.01	Block	Lot	Address
0223-311.01-1.02	311.01	1.02	Null
0223-311.01-1.03	311.01	1.03	Null
Block 312	Block	Lot	Address
0223-312-3	312	3	Null
0223-312-4.01	312	4.01	246 Main Street
0223-312-4.02	312	4.02	248 Main Street
0223-312-5	312	5	250 Main Street
0223-312-6	312	6	252-258 Main Street
0223-312-10	312	10	Null
0223-312-14.01	312	14.01	262 Main Street
0223-312-14.02	312	14.02	264 Main Street
0223-312-14.03	312	14.03	266 Main Street
0223-312-14.04	312	14.04	268 Main Street
0223-312-14.05	312	14.05	270 Main Street
0223-312-18	312	18	274 Main Street
0223-312-20	312	20	259 Moore Street
0223-312-21	312	21	Null
0223-312-22	312	22	Null
Block 313	Block	Lot	Address
0223-313-1	313	1	200-218 State Street
0223-313-5	313	5	207 Main Street
0223-313-6	313	6	199-205 Main Street
0223-313-7	313	7	Null
0223-313-7.01	313	7.01	191-195 Main Street
0223-313-8	313	8	197 Main Street
0223-313-9	313	9	Null
0223-313-10	313	10	Null
0223-313-11.01	313	11.01	181 Main Street
0223-313-11.02	313	11.02	187 Main Street
Block 314	Block	Lot	Address
0223-314-1	314	1	226 State Street
0223-314-2	314	2	236-244 State Street
0223-314-6	314	6	17-19 Salem Street
0223-314-8	314	8	15 Salem Street
0223-314-9.01	314	9.01	237 Main Street
0223-314-9.02	314	9.02	11 Salem Street

Area in Need of Rehabilitation Lot and Block Numbers

0223-314-9.03	314	9.03	231 Main Street
0223-314-10	314	10	227-229 Main Street
0223-314-11	314	11	223 Main Street
0223-314-12.01	314	12.01	10 Banta Place
0223-314-12.02	314	12.02	20-22 Banta Place
0223-314-12.03	314	12.03	213 Main Street
0223-314-12.04	314	12.04	215 Main Street
0223-314-12.05	314	12.05	215 1/2 Main Street
0223-314-12.06	314	12.06	217 Main Street
0223-314-12.07	314	12.07	219 Main Street
0223-314-12.08	314	12.08	221 Main Street
Block 315	Block	Lot	Address
0223-315-1	315	1	18 Salem Street
0223-315-2	315	2	22-24 Salem Street
0223-315-3	315	3	248 State Street
0223-315-4	315	4	254 State Street
0223-315-5	315	5	256 State Street
0223-315-6	315	6	Null
0223-315-7	315	7	264-266 State Street
0223-315-32.01	315	32.01	241 Main Street
0223-315-32.02	315	32.02	16 Salem Street
Block 316	Block	Lot	Address
0223-316-3	316	3	65 Central Avenue
0223-316-1	316	1	216-222 Union Street
Block 401	Block	Lot	Address
0223-401-8	401	8	330 Main Street
0223-401-9	401	9	336 Main Street
0223-401-10	401	10	340 - 342 Main Street
0223-401-12.01	401	12.01	346 Main Street
0223-401-12.02	401	12.02	Null
0223-401-12.03	401	12.03	344 Main Street
0223-401-12.04	401	12.04	9-11 Passaic Street
0223-401-12.05	401	12.05	Null
0223-401-13.01	401	13.01	350-352 Main Street
0223-401-13.02	401	13.02	348 Main Street
0223-401-22	401	22	329 River Street
Block 401.01	Block	Lot	Address
0223-401.01-1.02	401.01	1.02	286/302 Main Street
0223-401.01-2	401.01	2	304 Main Street
0223-401.01-3.01	401.01	3.01	308 - 310 Main Street
0223-401.01-3.02	401.01	3.02	306 Main Street
0223-401.01-4	401.01	4	312 - 314 Main Street
Block 402	Block	Lot	Address
0223-402-12	402	12	360 Main Street
0223-402-16.01	402	16.01	374 Main Street
0223-402-16.02	402	16.02	375 River Street
0223-402-17.01	402	17.01	382 Main Street
0223-402-17.02	402	17.02	378 Main Street
0223-402-18	402	18	Null
0223-402-18.01	402	18.01	11 Ward Street
0223-402-18.02	402	18.02	395 River Street
0223-402-19.01	402	19.01	392 Main Street
0223-402-19.02	402	19.02	7 Ward Street
Block 403	Block	Lot	Address

0223-403-10.01	403	10.01	9 Anderson Street
0223-403-10.03	403	10.03	Null
Block 405	Block	Lot	Address
0223-405-3	405	3	440 - 468 Main Street
0223-405-14	405	14	480 Main Street
Block 406	Block	Lot	Address
0223-406-1.01	406	1.01	540 Main Street
0223-406-1.02	406	1.02	529 River Street
0223-406-1.03	406	1.03	492 Main Street
0223-406-8	406	8	533 River Street
Block 407	Block	Lot	Address
0223-407-16	407	16	352 State Street
0223-407-18	407	18	360 State Street
0223-407-20.01	407	20.01	372 State Street
0223-407-20.02	407	20.02	370 State Street
0223-407-23	407	23	19 Passaic Street
0223-407-34	407	34	355 Main Street
0223-407-35	407	35	325-335 Main Street
Block 407.01	Block	Lot	Address
0223-407.01-38	407.01	38	299 Main Street
Block 408	Block	Lot	Address
0223-408-15	408	15	381 Main Street
Block 409	Block	Lot	Address
0223-409-1	409	1	16 Ward Street
0223-409-2	409	2	Null
0223-409-4	409	4	436 Union Street
0223-409-14.01	409	14.01	5 Anderson Street
0223-409-14.02	409	14.02	9-15 Anderson Street
0223-409-14.03	409	14.03	423 - 425 Main Street
0223-409-14.04	409	14.04	22 - 24 Ward Street
0223-409-16	409	16	417 - 421 Main Street
0223-409-17	409	17	409 Main Street
0223-409-18	409	18	405 Main Street
0223-409-19.01	409	19.01	14 Ward Street
Block 410	Block	Lot	Address
0223-410-18	410	5	22 Anderson Street
0223-410-18	410	7.01	26 Anderson Street
0223-410-18	410	7.02	32 Anderson Street
0223-410-18	410	9.01	50 Anderson Street
0223-410-18	410	9.02	40-46 Anderson Street
0223-410-18	410	12	43 Maple Avenue
0223-410-18	410	20	17 Maple Avenue
0223-410-18	410	22	453 Main Street
Block 411	Block	Lot	Address
0223-411-18	411	1	10/16 Maple Avenue
0223-411-18	411	2	22 Maple Avenue
0223-411-18	411	2.02	32 -44 Maple Avenue
0223-411-18	411	3	24-26 Maple Avenue