



PROFESSIONAL OFFICE IN SOUTH TUMWATER



1342 88th Avenue SE, Tumwater, WA

LISTING INFORMATION

Office space available in Tumwater in a shared building with one private restroom, five offices, a storage/work room, and ample parking.

1,100 SF

\$22.00/SF
MODIFIED GROSS

CBA# 41623039



rants.group/134288thAveSEvt

Danielle Rants, ccim
VP, MANAGING BROKER
360-352-7822
danielle@rantsgroup.com

Ian Zarosinski
BROKER
(360) 800-5808
ian@rantsgroup.com

360-943-8060
RANTSGROUP.com

This information, while obtained from sources we deem reliable, is not guaranteed. It is provided without any representation, warranty or guarantee, expressed or implied as to its accuracy. Prospective buyer or tenant should conduct an independent investigation and verification of all matters deemed to be material, including, but not limited to, statements of income and expenses. Consult your attorney, accountant, or other professional advisor.

1342 88th Avenue SE, Tumwater, WA

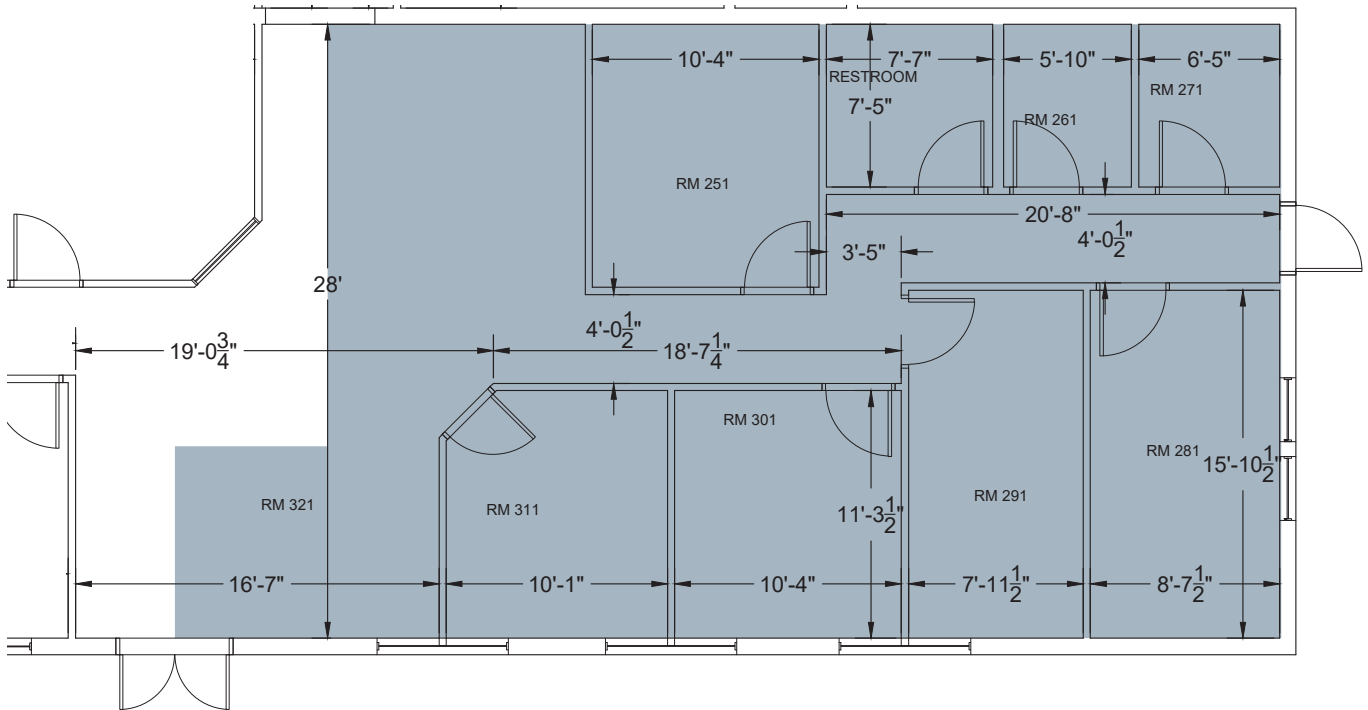

AVAILABLE



THIS FLOORPLAN IS NOT TO SCALE
SIZES AND DIMENSIONS ARE APPROXIMATE, ACTUAL MAY VARY.



CONTACT

Danielle Rants, ccim
VP, MANAGING BROKER
360-352-7822
danielle@rantsgroup.com

Ian Zarosinski
BROKER
(360) 800-5808
ian@rantsgroup.com



rants.group/134288thAveSEvt

This information, while obtained from sources we deem reliable, is not guaranteed. It is provided without any representation, warranty or guarantee, expressed or implied as to its accuracy. Prospective buyer or tenant should conduct an independent investigation and verification of all matters deemed to be material, including, but not limited to, statements of income and expenses. Consult your attorney, accountant, or other professional advisor.

360-943-8060 | RANTSGROUP.com