



**FOR
LEASE**

Pharaoh Plaza Shopping Center
4701 Ayers Street, Corpus Christi, TX 78415
1,250 sq ft office, retail or showroom suite for lease



Jack and Ben Super
SuperTex Properties L.P.
Super Commercial Properties
4531 Ayers Street, Suite 201, Corpus Christi, TX 78415
(361) 853-3003 Fax: (361) 853-9141 cell: (361) 215-8018



SuperTex Properties
4531 Ayers, Suite 201
Corpus Christi, Texas 78415
Phone (361) 853-3003 Fax: (361) 853-9141
zjsuper@gmail.com

Pharaoh Plaza Shopping Center
4701 Ayers Street, Corpus Christi TX 78415
1,250 sq ft office, retail or showroom suites for lease

Location: Pharaoh Plaza is located between Ayers Street and the Crosstown Expressway just north of the SPID freeway. It has entrances from both Ayers Street and the Crosstown Expressway access road.

Description: Pharaoh Plaza is a 47,000 square feet shopping center with 29 rental suites including a freestanding drive thru convenience store.

Acreage: Situated on 5 acres

Parking: There are 283 parking spaces

Suite Description: All suites are 50 feet deep.
Frontages vary from 20 to 40 feet and are all glass.

Now Available: Suite 104 1,250 sq ft \$1,400 per month (\$1.12/sf)
Large open retail area, office, storage & 2 restrooms
Ideal retail, office or showroom location

Features: No CAM's
Each suite is individually metered for electricity.
Each Tenant pays for its own power.
Landlord pays water and supplies dumpsters.

Broker Coop: 3% Broker Coop Encouraged

Pharaoh Plaza Shopping Center
4701 Ayers Street, Corpus Christi TX 78415
Suite 104
1,250 Sq Feet
Large open retail area, office, storage & 2 restrooms

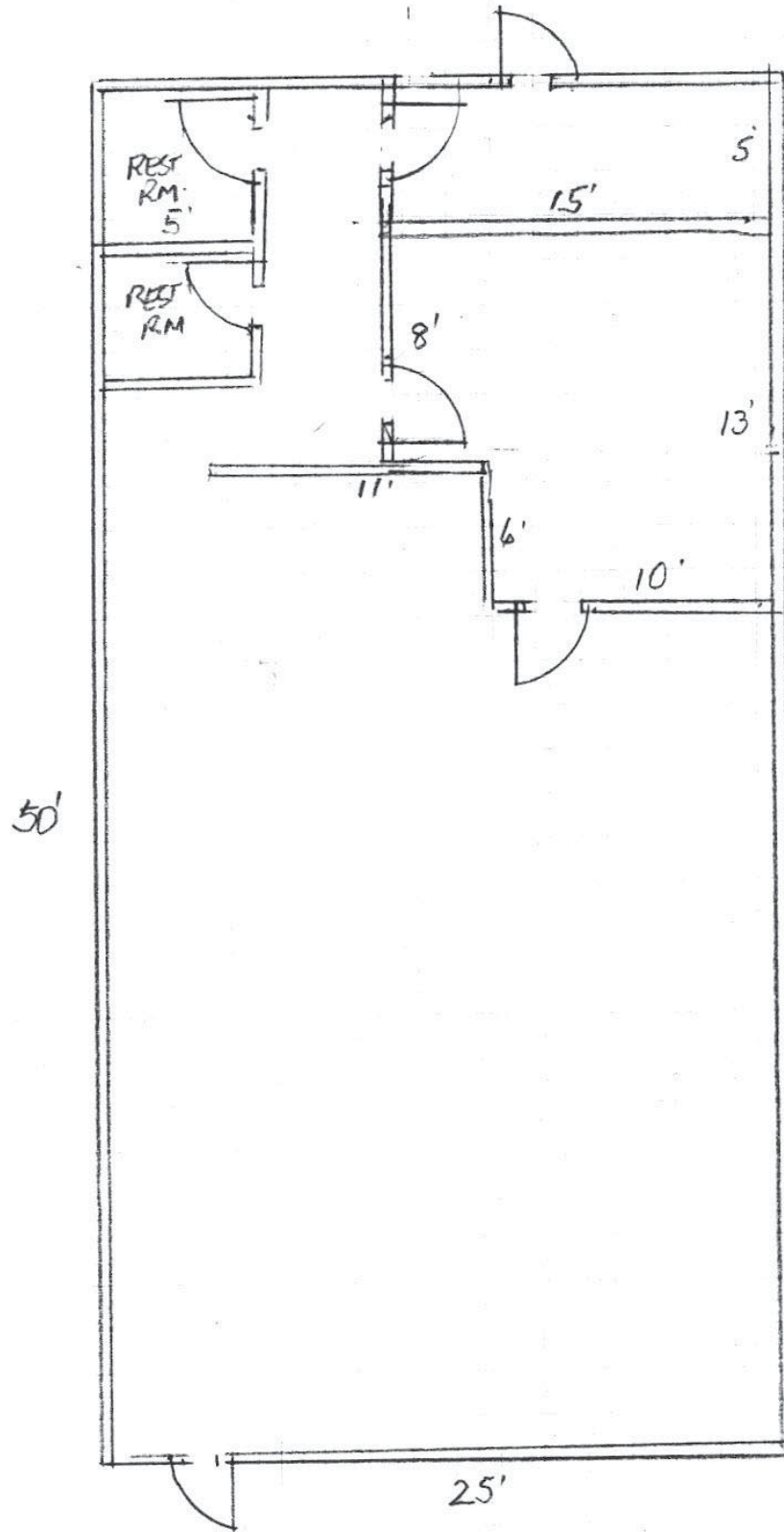

CROSSTOWN FREEWAY ACCESS RD

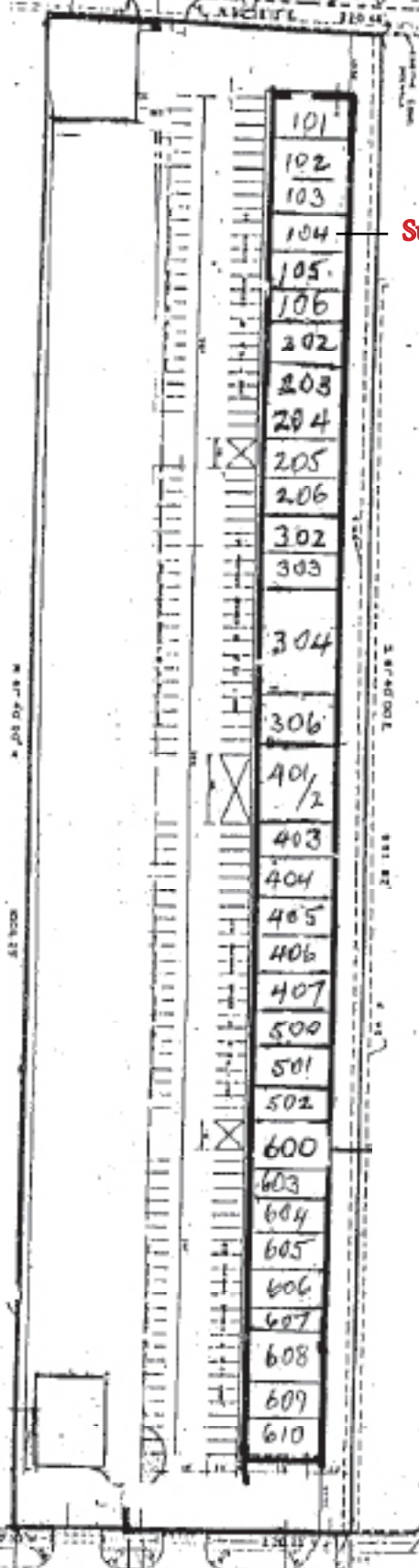

Subject

SITE PLAN
PHARROT PLAZA
4701 AYERS ST.
CORPUS CHRISTI TX 78415

AYERS STREET 4701 AYERS



Suite 104 Photos



Suite 104 Photos



Pharaoh Plaza Shopping Center
4701 Ayers Street, Corpus Christi, TX 78415

