

FOR LEASE



ZACUTO GROUP  
COMMERCIAL REAL ESTATE

6363  
WILSHIRE  
BOULEVARD

CREATIVE OFFICES

# LEASE DETAILS

6363 WILSHIRE BOULEVARD  
LOS ANGELES, CA 90048

## AVAILABILITIES

Suite 114 277 SF  
Suite 117 375 SF  
Suite 407 319 SF  
Suite 516 1,100 SF

## ASKING RATE

\$3.50/SF FSG

## TERM

Negotiable

## PARKING

2:1,000

\$175-unreserved

\$225-reserved

- Premier creative office building along dynamic stretch of Wilshire Boulevard
- Light and bright suites with large operable windows, and open views of LA skyline
- Central Los Angeles location, walkable to The Grove, Beverly Hills, and excellent restaurants and retail including HiHo Cheeseburger, KazuNori, Uovo, The Roof on Wilshire, and other notable amenities



## LISTING TEAM



### **JAKE ZACUTO**

Managing Director  
310.469.9012

jake@zacutogroup.com  
BRE #01377441

### **LEOR BINSHTOCK**

Executive Vice President  
310.469.9014

leor@zacutogroup.com  
BRE #01773798

### **JOHN LOGAN**

Senior Director  
931.561.9561

john@zacutogroup.com  
BRE# 02161147

# 6363

## WILSHIRE BOULEVARD

- **MODERN HIGH STYLE INTERIORS; INDUSTRIAL WITH CREATIVE EDGE**
- **LIGHT AND BRIGHT SPACES WITH FLEXIBLE CONFIGURATIONS**
- **OPERABLE WINDOWS**
- **MANY SUITES WITH CITY AND MOUNTAIN VIEWS**
- **ON-SITE PARKING**



FOR LEASE  
**SUITE 117**

6363 WILSHIRE BLVD, LOS ANGELES, CA 90048



**FOR LEASE**  
**SUITE 117 - FLOOR PLAN**

6363 WILSHIRE BLVD, LOS ANGELES, CA 90048

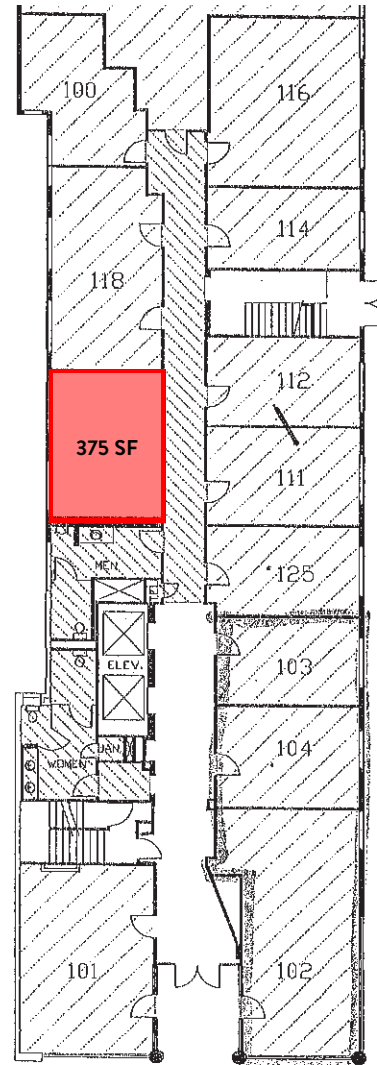

FOR LEASE  
**SUITE 114**

6363 WILSHIRE BLVD, LOS ANGELES, CA 90048



FOR LEASE  
SUITE 114 - FLOOR PLAN

6363 WILSHIRE BLVD, LOS ANGELES, CA 90048

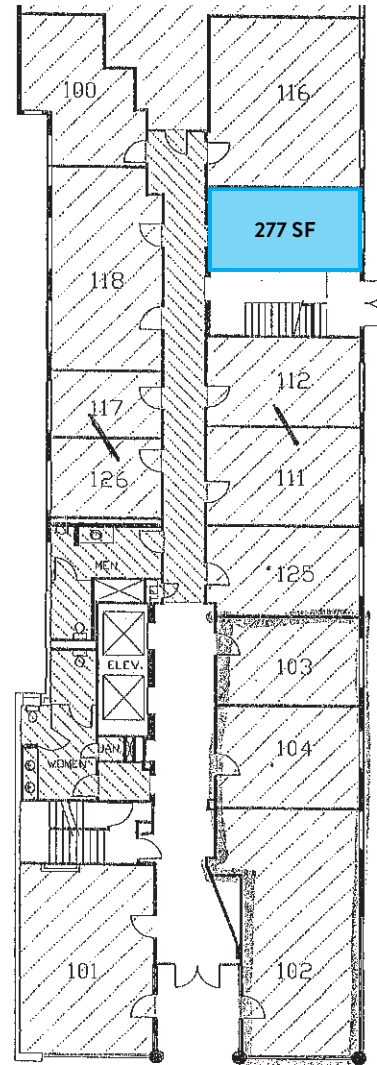

FOR LEASE  
**SUITE 407**

6363 WILSHIRE BLVD, LOS ANGELES, CA 90048





**FOR LEASE**  
**SUITE 407 - FLOOR PLAN**

6363 WILSHIRE BLVD, LOS ANGELES, CA 90048

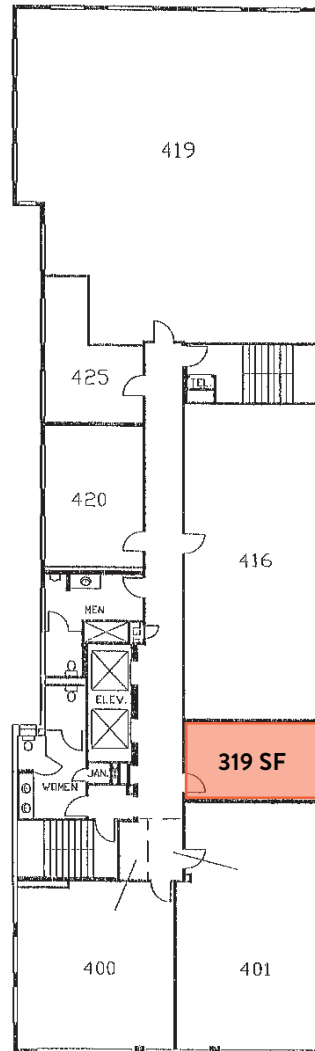

6363  
WILSHIRE  
BOULEVARD

DOWNTOWN LA



LACMA

Craft Contemporary



PETERSEN  
AUTOMOTIVE MUSEUM



ANAT EBGI  
GALLERY

MID-WILSHIRE



UOVO  
PASTA

THE ROOFTOP  
ON WILSHIRE



THE GROVE

WEST HOLLYWOOD

BEVERLY HILLS



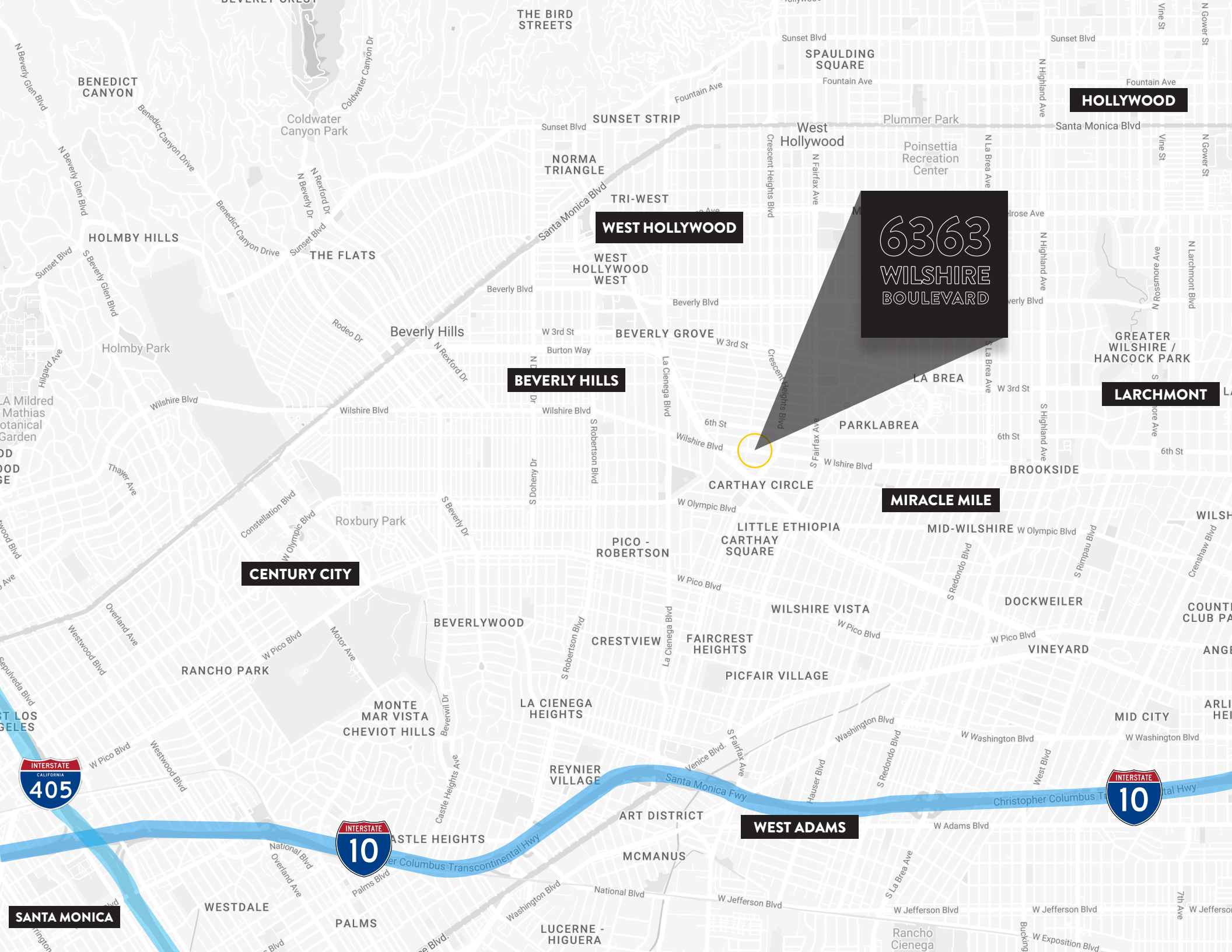

**HOLLYWOOD**

**WEST HOLLYWOOD**

**BEVERLY HILLS**

**CENTURY CITY**

**MIRACLE MILE**

**LARCHMONT**

**WEST ADAMS**

**SANTA MONICA**



**6363  
WILSHIRE  
BOULEVARD**

6363  
WILSHIRE  
BOULEVARD



**ZACUTO GROUP**  
COMMERCIAL REAL ESTATE

**JAKE ZACUTO**

*Managing Director*

310.469.9012

jake@zacutogroup.com

BRE #01377441

**LEOR BINSHTOCK**

*Executive Vice President*

310.469.9014

leor@zacutogroup.com

BRE #01773798

**JOHN LOGAN**

*Senior Director*

931.561.9561

john@zacutogroup.com

BRE# 02161147

**ZACUTOGROUP.COM | 310.469.9300**



No warranty, express or implied, is made as to the accuracy of the information contained herein. This information is submitted subject to errors, omissions, change of price, rental or other conditions, withdrawal without notice. All parties who receive this material should not rely on it, but should use it as a starting point of analysis, and should independently confirm the accuracy of the information contained herein through a due diligence review of the books, records, files and documents that constitute reliable sources of the information described herein. Logos and images are for identification purposes only and may be trademarks of their respective companies. All terms provided are approximate. Leasee to verify. 10/2024