

# FOR SALE

Brooker Creek Corporate Center Professional Office Condo  
720 Brooker Creek Blvd., Suite 221, Oldsmar, FL 34677

## FLOOR PLAN

2,767 Square Feet  
Second Floor

Reception Area  
5 Private Offices  
Conference Room  
Kitchenette  
2 Restrooms  
Storage Room  
Open area for workstations  
Electrical Closet  
IT Closet

Capacity: 13-15 people

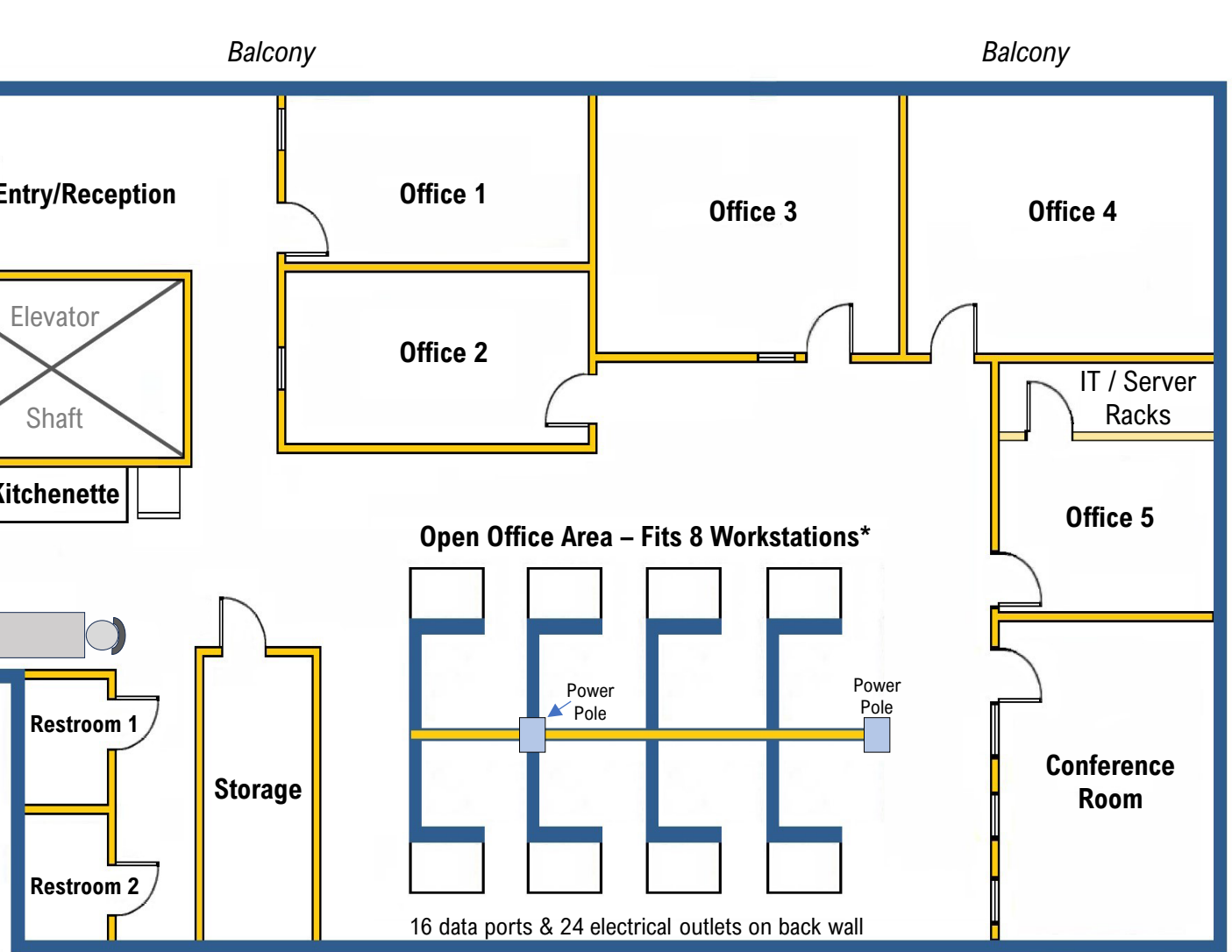

### Kori Billings CCIM

Broker Associate

C | 813.997.3341

Kori@BridgewaterCommercial.com

*\*Workstations not included*



The information contained herein has been obtained from sources considered reliable. However, no warranty expressed or implied has been made as to the accuracy of the information provided, no liability assumed for errors or omissions. Bridgewater Commercial Real Estate is a full service commercial real estate brokerage.