

R&D, Office | For Lease



CBRE

DOLLINGER PROPERTIES

# Koll Business Park

San Jose, CA 95122

[www.cbre.com/siliconvalley](http://www.cbre.com/siliconvalley)

±1,200 - ±2,540 SF





## AVAILABLE SUITES

BUILDING	SUITE	SIZE	PRICE/SF	NOTES
1425	107	±2,000	\$1.50	90% Office, 10% Warehouse, GL Door
1435	105	±2,340	\$1.45	50% Dropped Ceiling Office/50% Warehouse, GL Door, Partial Two-Story Unit
1435	108	±2,340	\$1.50	40% Office, 60% Warehouse, GL Door
1445	107	±1,800	\$1.50	40% Office, 60% Warehouse, GL Door
1450	103	±2,540	\$1.50	Office, Warehouse, GL Door
1450	105	±2,540	\$1.50	30% Office, 70% Warehouse
1560 N 4th	101	±1,200	\$2.10	60% Dropped Ceiling Office, GL Door

## PROPERTY HIGHLIGHTS

- + Eleven Building Campus Totaling ±181,305 SF
- + Mix of Office and Industrial Units; Can Support Multiple Users
- + Close Proximity to San Jose International Airport
- + Short Walk to Light Rail Station on North First Street
- + Freeway Visibility
- + Easy Access from Highway 101

# Floorplan

Koll Business Park  
San Jose, CA 95122

**1425 KOLL CIRCLE**  
**SUITE 107**  
±2,000 SF

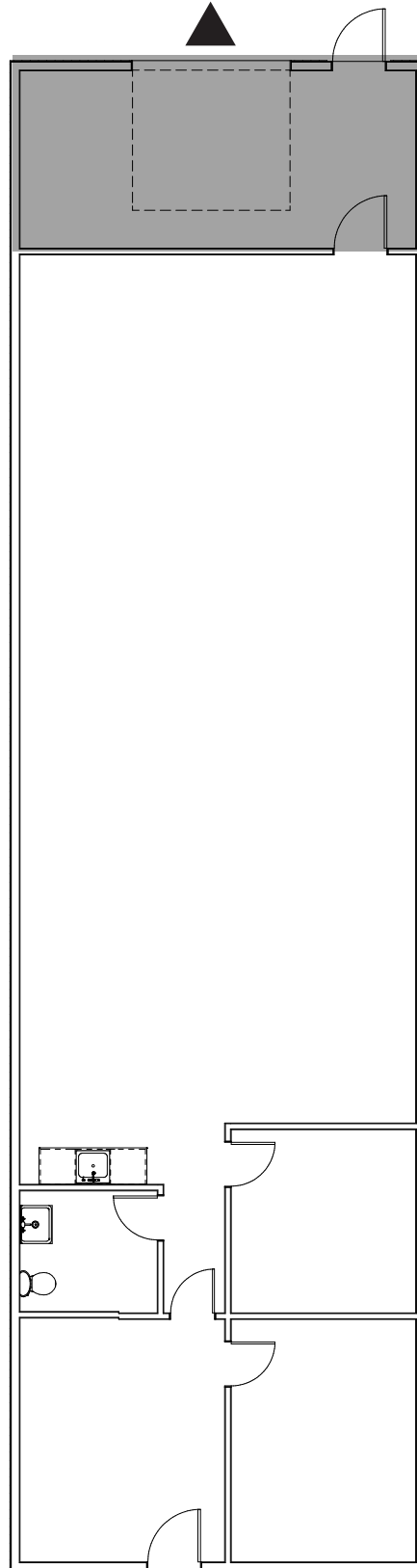

■ WAREHOUSE

▲ GRADE LEVEL DOOR

NOT TO SCALE

# Floorplan

Koll Business Park  
San Jose, CA 95122

**1435 KOLL CIRCLE**  
**SUITE 105**  
±2,340 SF

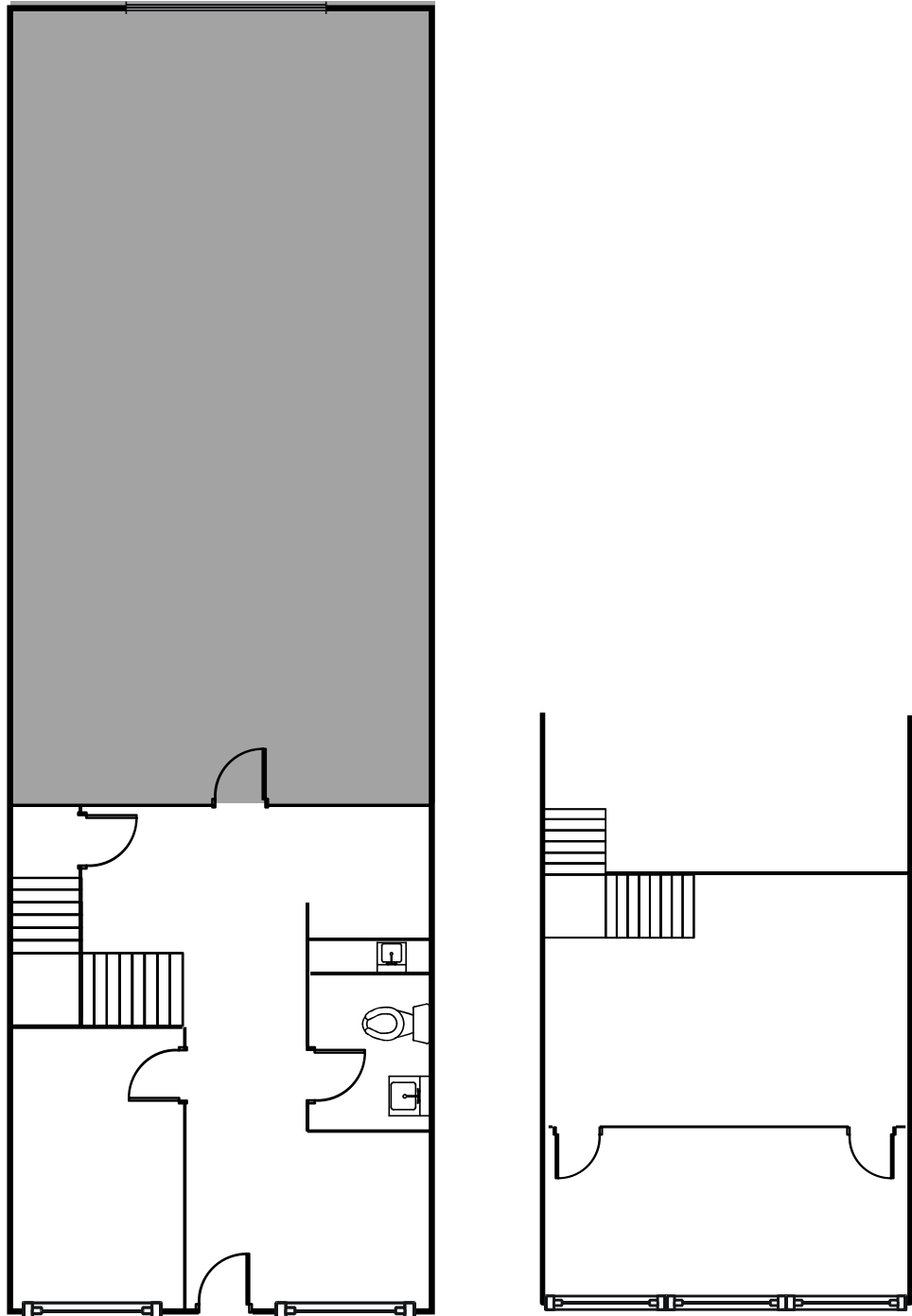

- WAREHOUSE
- ▲ GRADE LEVEL DOOR

NOT TO SCALE

# Floorplan

Koll Business Park  
San Jose, CA 95122

**1435 KOLL CIRCLE**  
**SUITE 108**  
±2,340 SF

- WAREHOUSE
  - ▲ GRADE LEVEL DOOR
- NOT TO SCALE

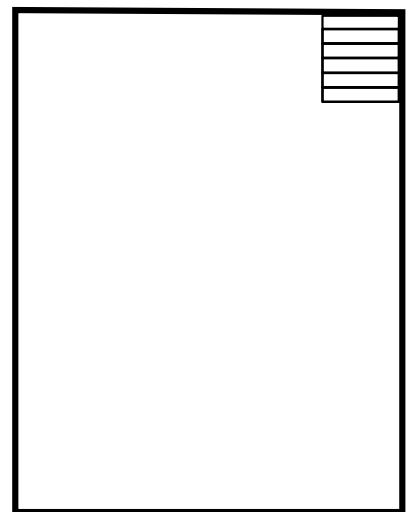
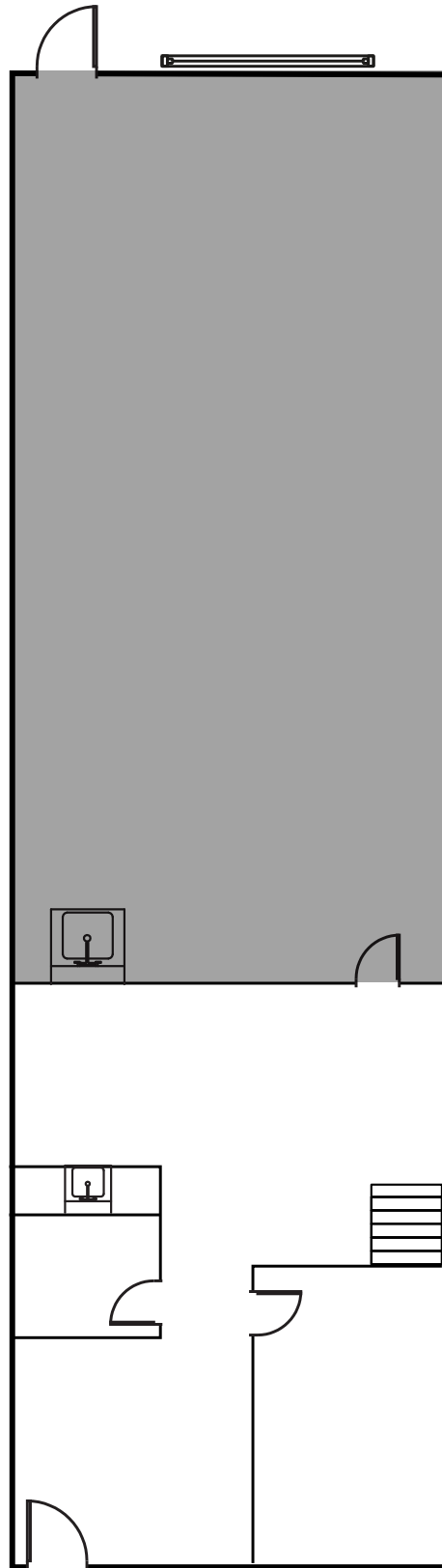



# Floorplan

Koll Business Park  
San Jose, CA 95122

**1445 KOLL CIRCLE**  
**SUITE 107**  
±1,800 SF

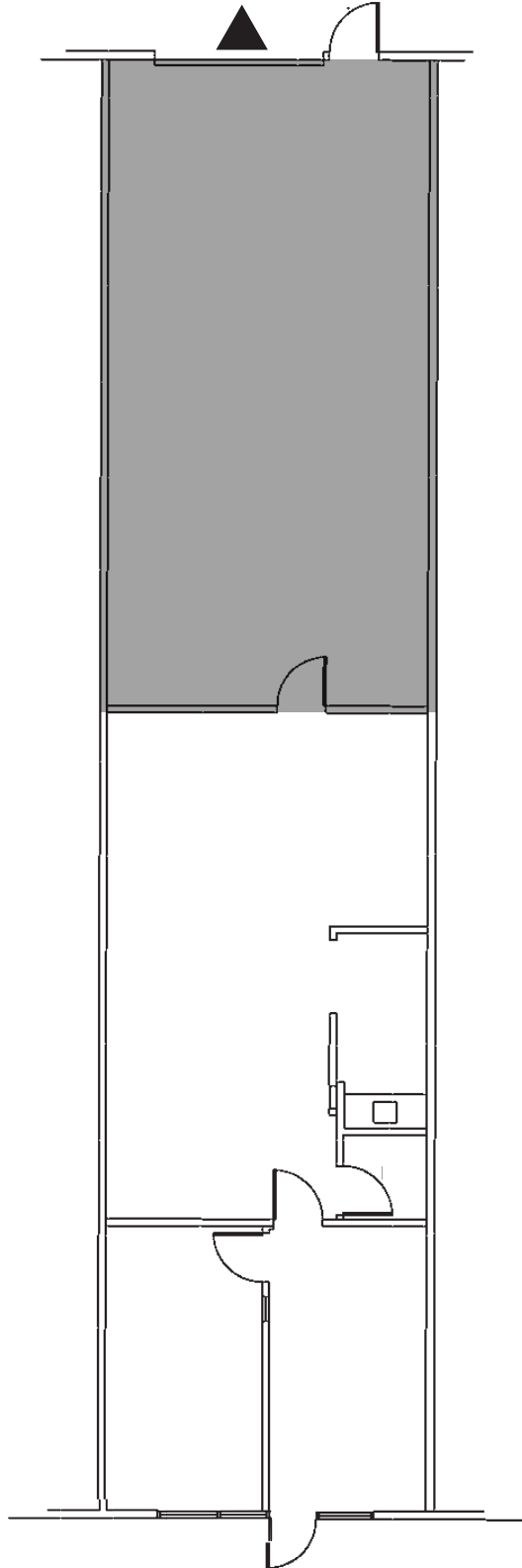

- WAREHOUSE
- GRADE LEVEL DOOR

NOT TO SCALE

# Floorplan

Koll Business Park

San Jose, CA 95122

**1450 KOLL CIRCLE**

**SUITE 103**

±2,540 SF

■ WAREHOUSE

▲ GRADE LEVEL DOOR

NOT TO SCALE

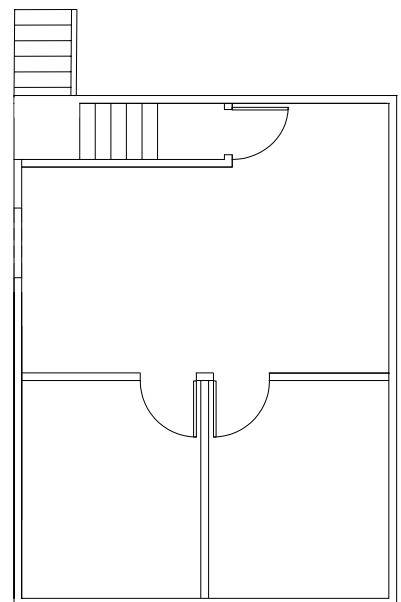
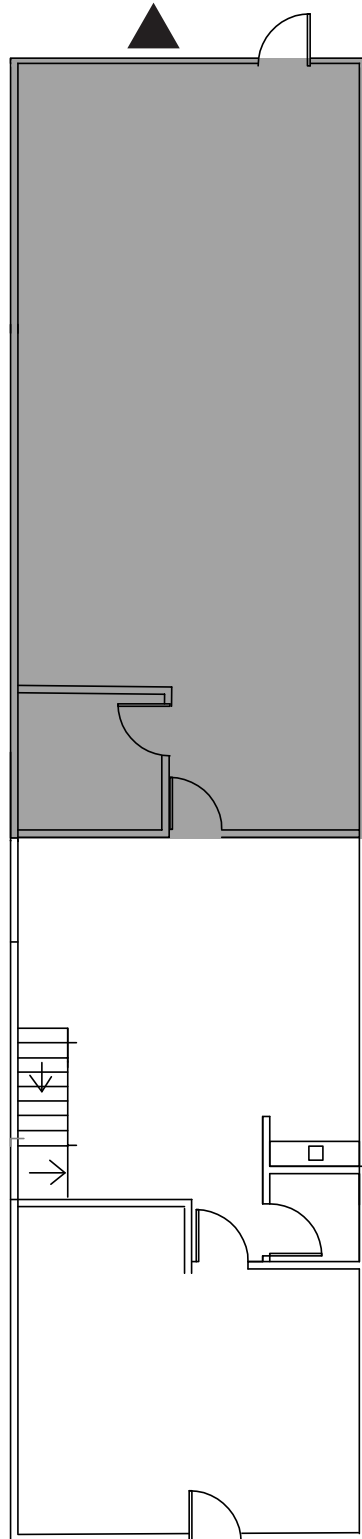

# Floorplan

Koll Business Park  
San Jose, CA 95122

**1450 KOLL CIRCLE**  
**SUITE 105**  
±2,540 SF

- WAREHOUSE
- ▲ GRADE LEVEL DOOR

NOT TO SCALE

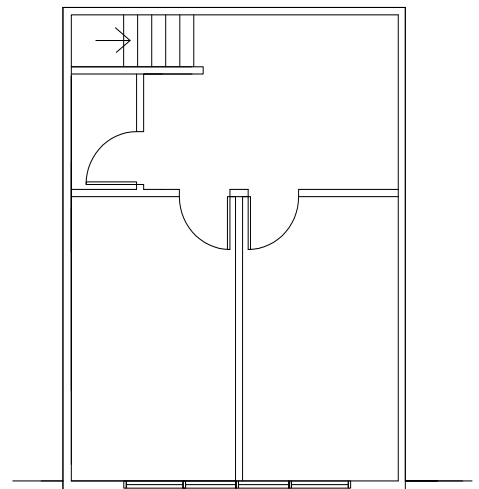
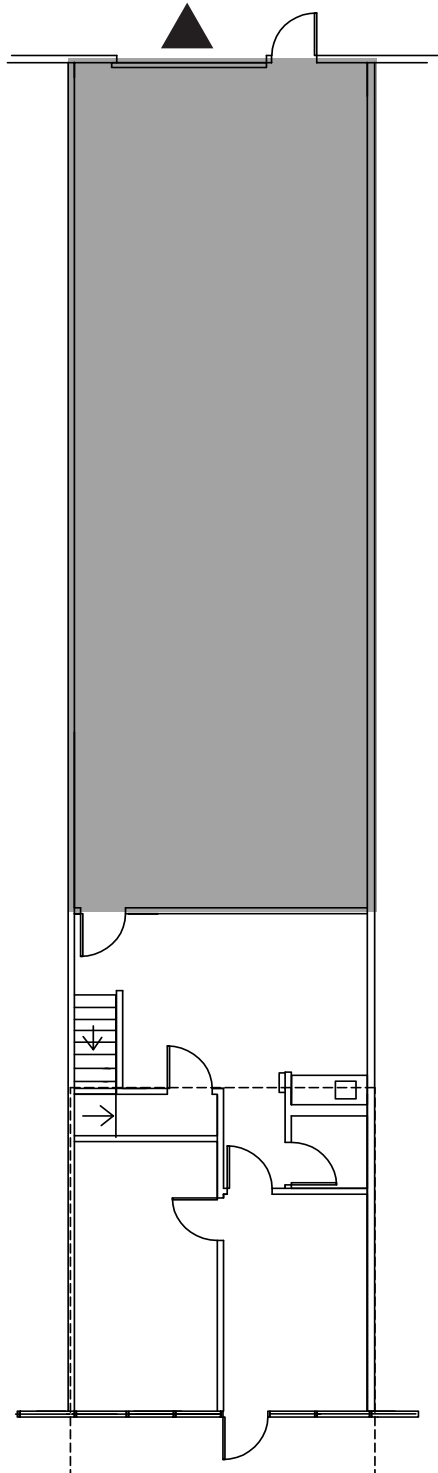



# Floorplan

Koll Business Park  
San Jose, CA 95122

**1560 4TH ST**  
**SUITE 101**  
±1,200 SF

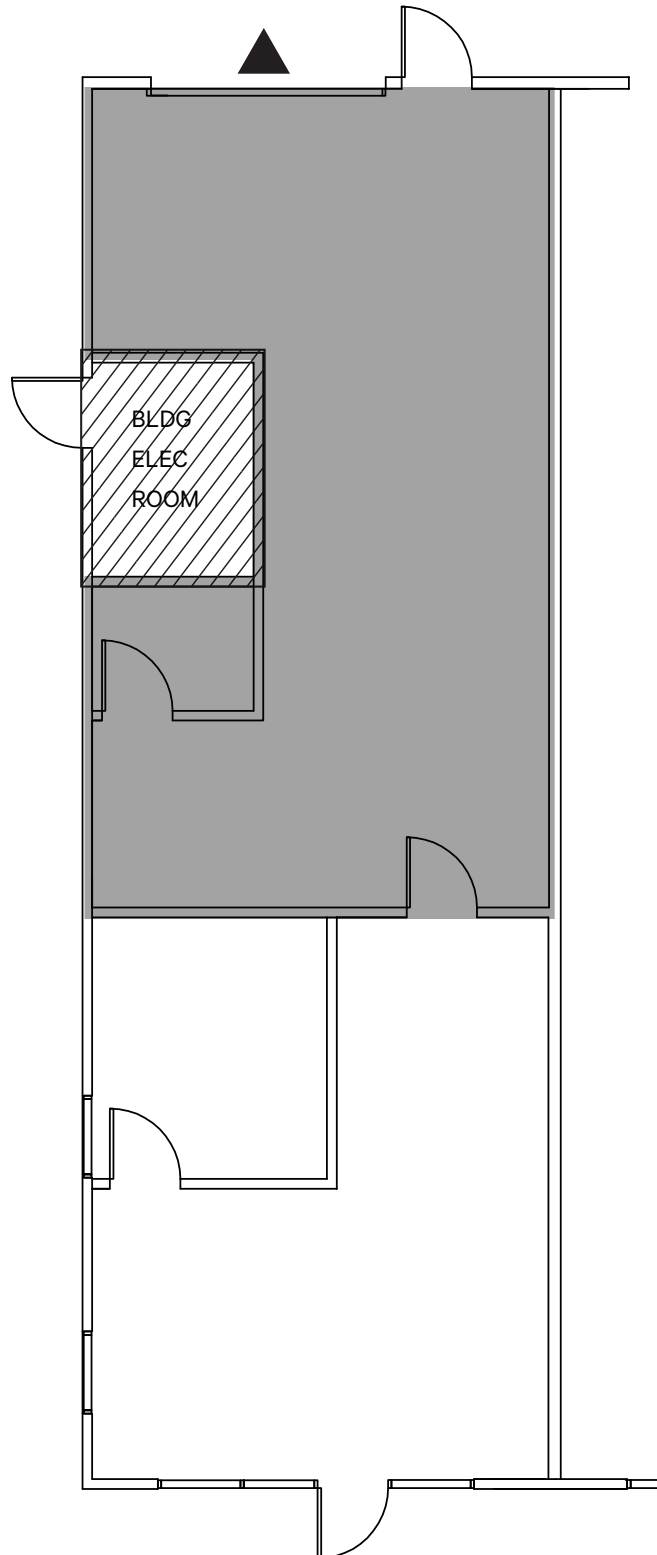

- WAREHOUSE
  - ▲ GRADE LEVEL DOOR
  - ▨ NOT A PART
- NOT TO SCALE

Koll Business Park

San Jose, CA 95112

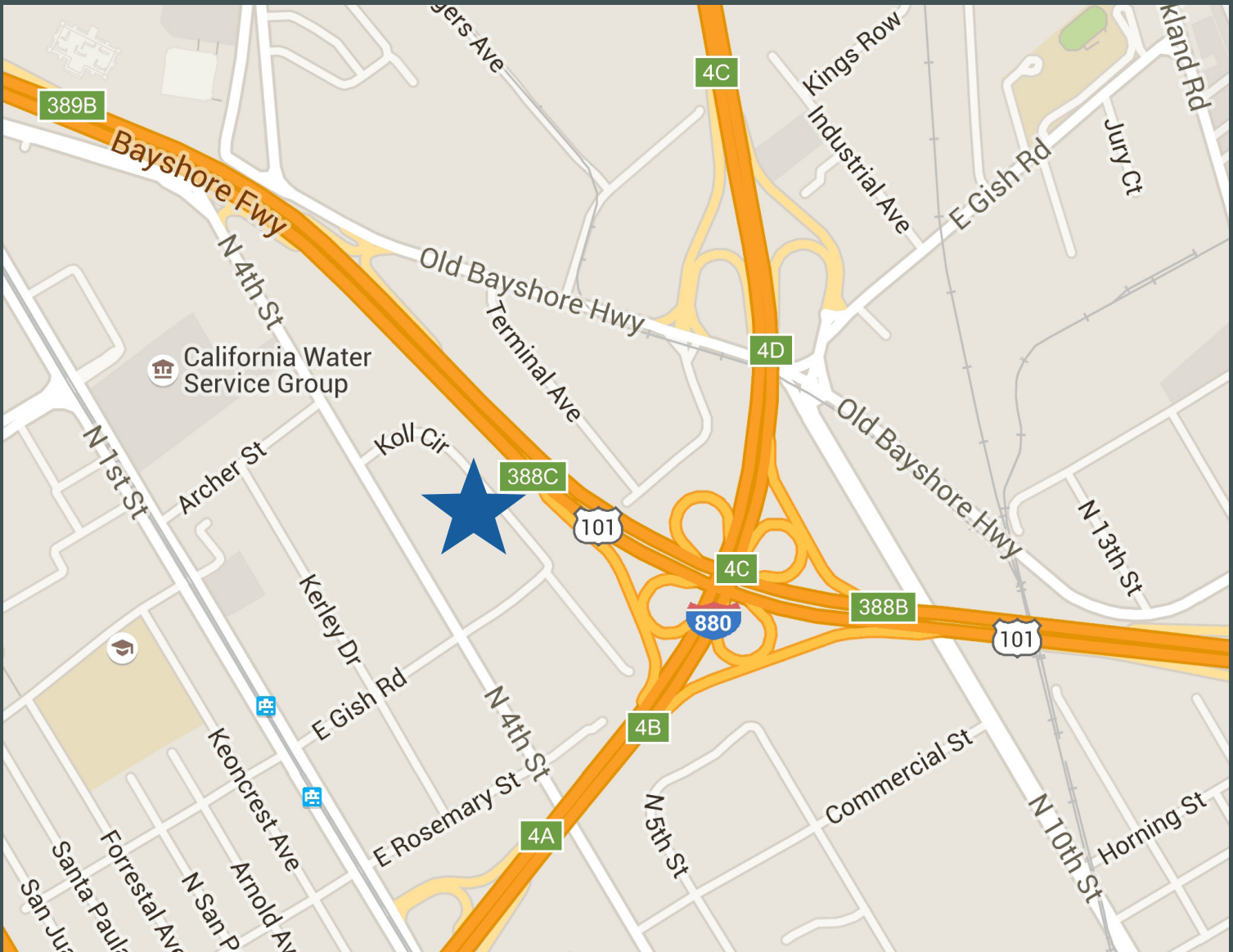

Contact Us

Paul Lyles

First Vice President  
+1 408 453 7443  
paul.lyles@cbre.com  
Lic. 01236021

Robbie Taylor

Senior Vice President  
+1 408 453 7489  
robbie.taylor2@cbre.com  
Lic. 01946325

© 2024 CBRE, Inc. All rights reserved. This information has been obtained from sources believed reliable but has not been verified for accuracy or completeness. CBRE, Inc. makes no guarantee, representation or warranty and accepts no responsibility or liability as to the accuracy, completeness, or reliability of the information contained herein. You should conduct a careful, independent investigation of the property and verify all information. Any reliance on this information is solely at your own risk. CBRE and the CBRE logo are service marks of CBRE, Inc. All other marks displayed on this document are the property of their respective owners, and the use of such marks does not imply any affiliation with or endorsement of CBRE. Photos herein are the property of their respective owners. Use of these images without the express written consent of the owner is prohibited.