

1 SITE PLAN
SCALE: 1"=20'-0"

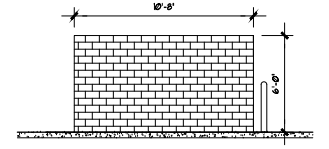
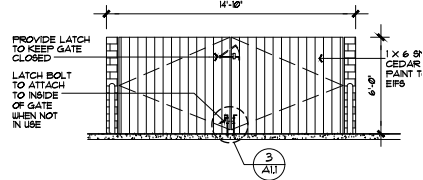
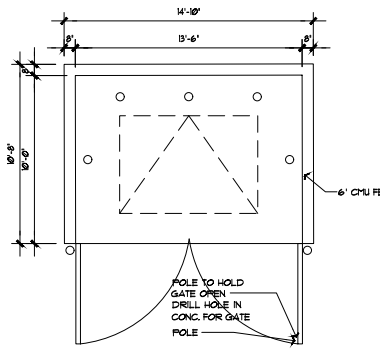

PHYSICAL ADDRESS:
4401 WEST RENO AVENUE
OKLAHOMA CITY, OKLAHOMA 73100

LEGAL DESCRIPTION:
UNPLTD PLY SUB SEC 35 IN 4U BEG
36.9FT E OF SW/4 BUA TH E296.37FT
N33.02PT W296.39FT S33.02PT TO BEG
SUBJ TO E87S OF RECORD

2 DUMPSTER PLAN AND ELEVATION
SCALE: 1/4"=1'-0"

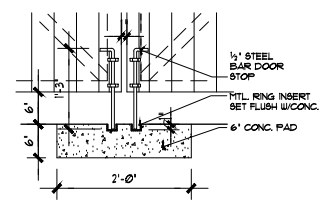

3 DETAIL
SCALE: 1"=1'-0"