

FOR LEASE

26 North Business Park II

5401-5501 NE Century Blvd, Hillsboro, OR

PACIFIC NW
PNW PROPERTIES



Imagine working in a
perfect space.

Location

- Well-located off HWY 26 and NW Century Blvd.
- Highly visible from HWY 26

Building Highlights

- New Construction
- Flexible sizes/configurations
- Space sizes ranging from 1,300 square feet to 4,000 square feet
- 16' ceiling clear height
- Grade level loading
- Locally-owned and managed by Pacific NW Properties
- Please call for competitive pricing and more info

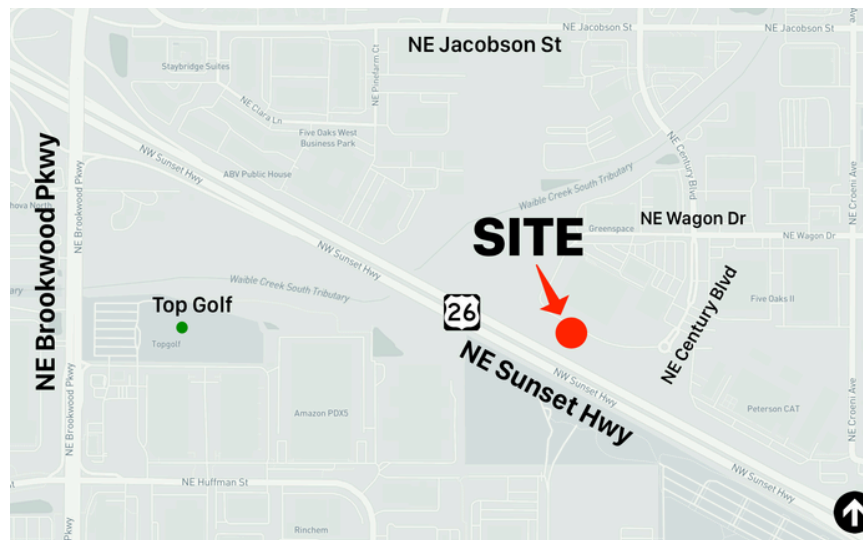

For more information, please contact:

Erin Gram & Evan Bernstein

(503) 626-3500

erin.gram@pnwprop.com

503-626-3500 | pnwprop.com

FOR LEASE

26 North Business Park II
5401-5501 NE Century Blvd
Hillsboro, Oregon

Because great people should have
great places.

PACIFIC NW
PNW PROPERTIES

Site Plan

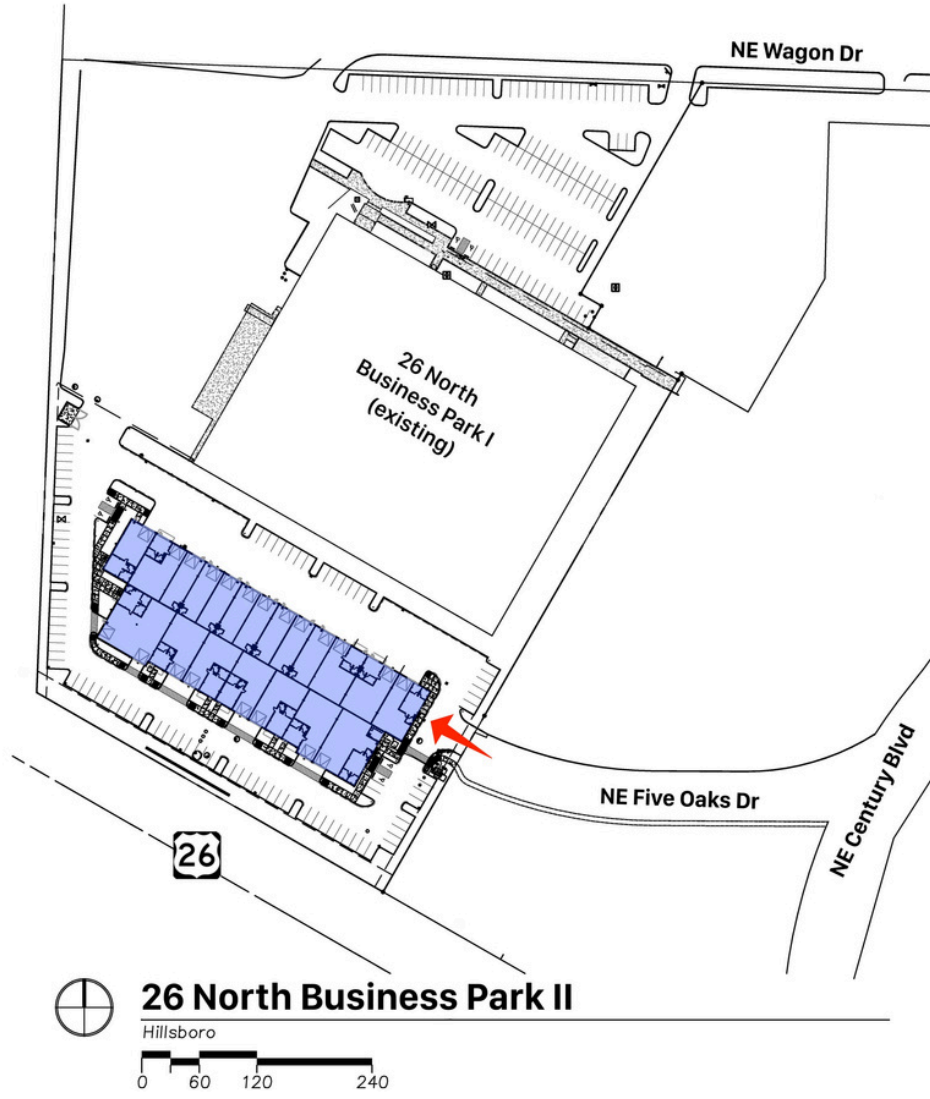
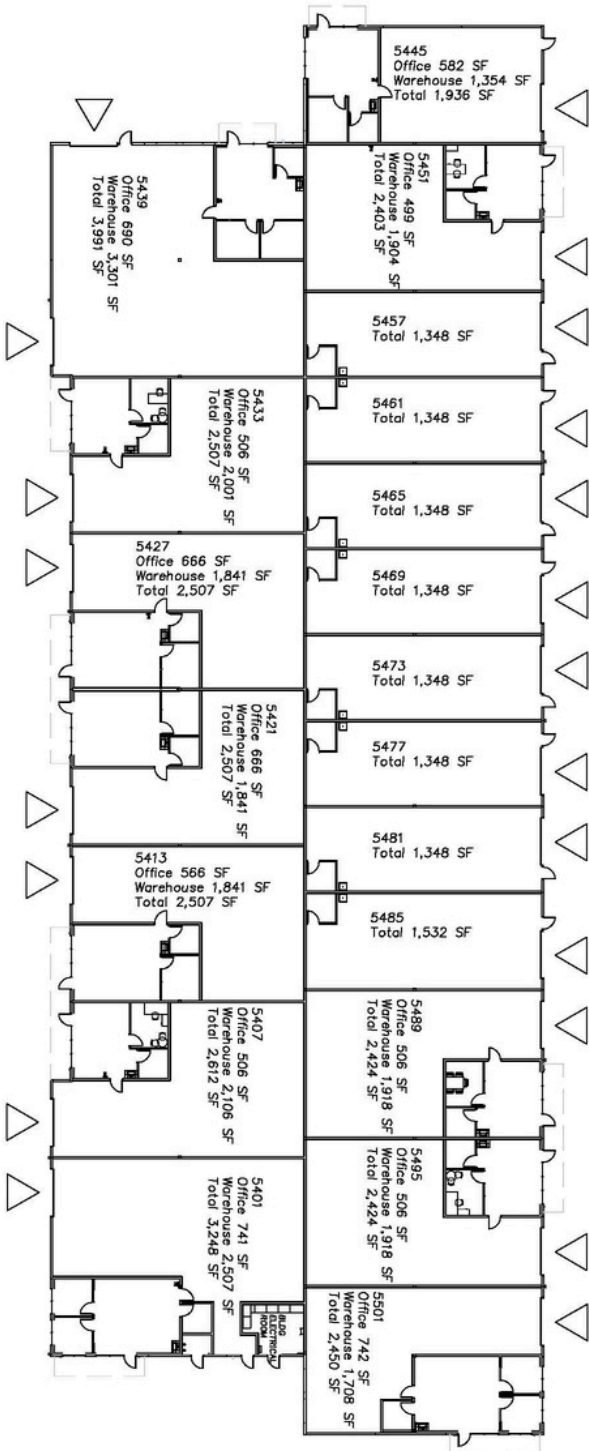

For more information, please contact:

Erin Gram & Evan Bernstein

(503) 626-3500

Erin.gram@pnwprop.com