

6451

NW 102ND AVENUE

DORAL, FL 33178

NORTH DORAL PARK



CBRE

PROPERTY FEATURES

	Suite 12
Bay Size	13,669 SF
Office	1,076 SF
Mezzanine	1,055 SF
Warehouse	11,538 SF
Loading	2 docks, 1 ramp
Clear Height	32'
Building Depth	140'-150'
Truck Court	120'
Sprinkler	ESFR
Lighting	LED
Available	Immediately
Lease Rate	\$19.50 (INNN)
2026 OpEx	\$4.15



SITE PLAN

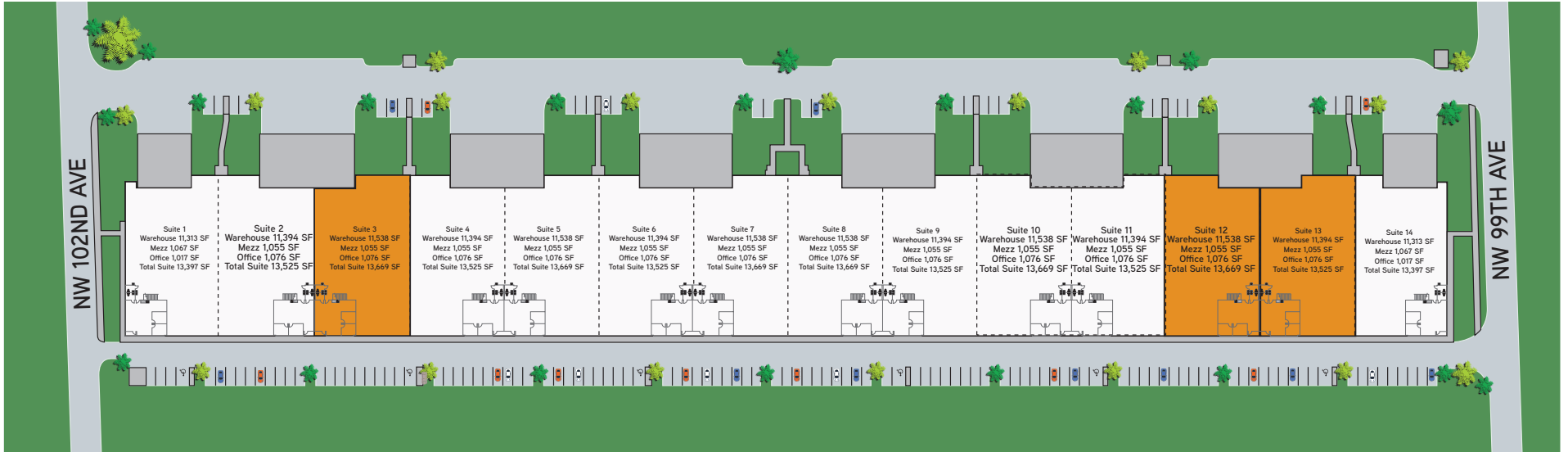

OFFICE PLANS

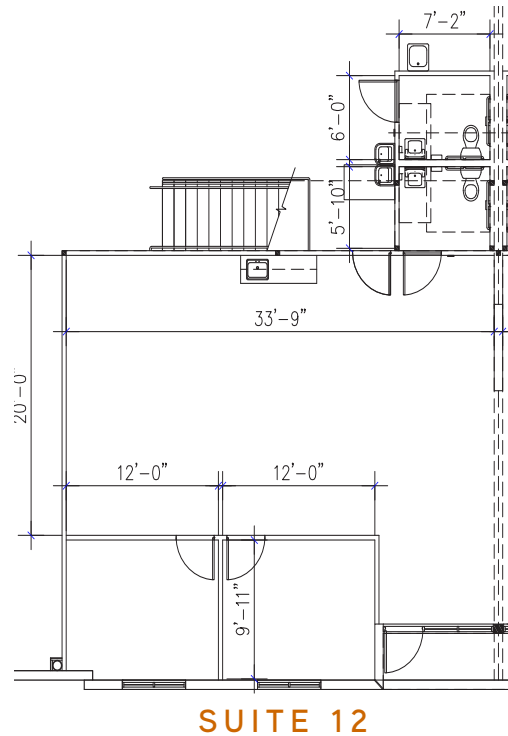

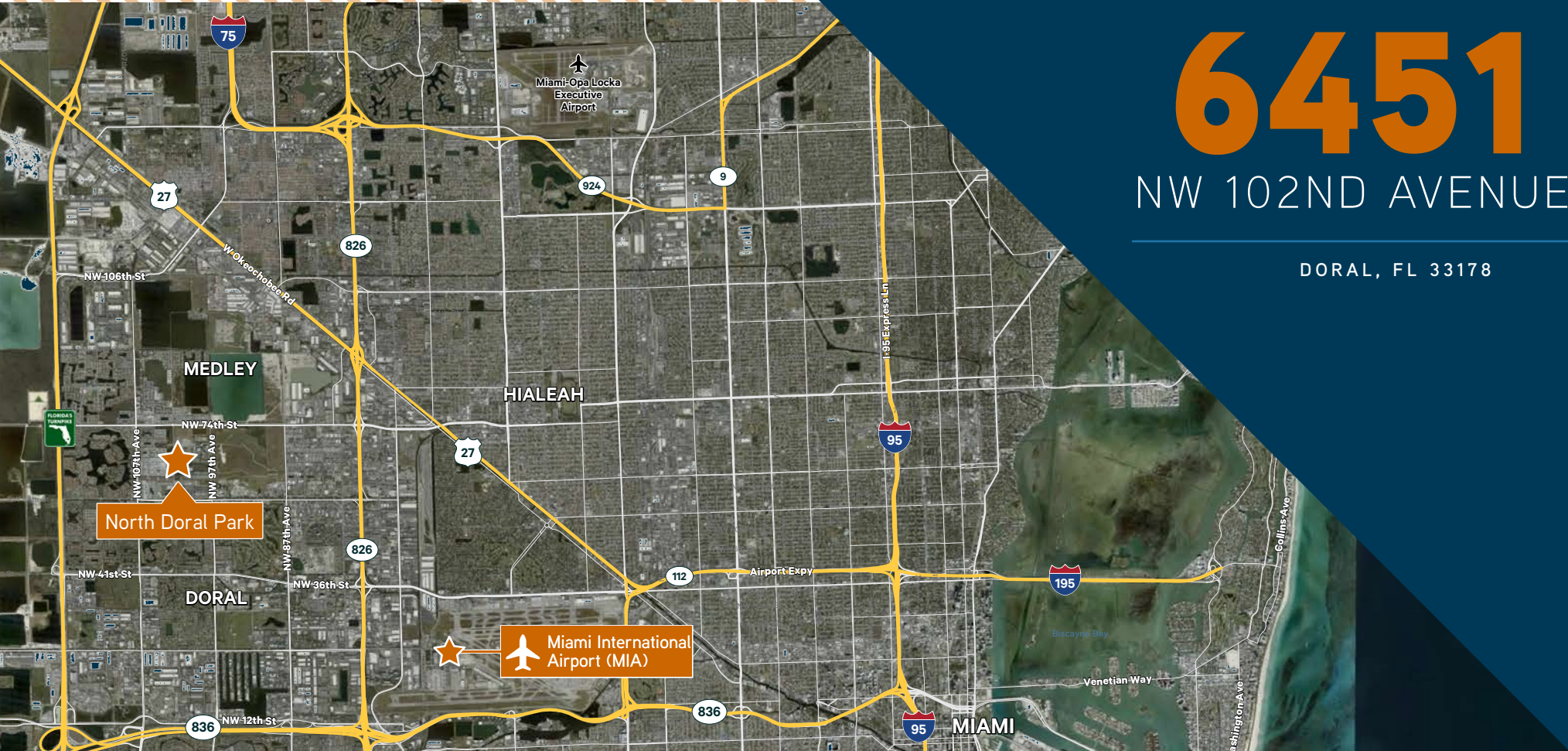

6451

NW 102ND AVENUE

DORAL, FL 33178

NORTH DORAL PARK

DEVIN WHITE

Executive Vice President
+1 305 381 6409
devin.white@cbre.com

ISABEL NAKASH

Associate
+1 347 860 1757
isabel.nakash@cbre.com

© 2026 CBRE, Inc. All rights reserved. This information has been obtained from sources believed reliable but has not been verified for accuracy or completeness. CBRE, Inc. makes no guarantee, representation or warranty and accepts no responsibility or liability as to the accuracy, completeness, or reliability of the information contained herein. You should conduct a careful, independent investigation of the property and verify all information. Any reliance on this information is solely at your own risk. CBRE and the CBRE logo are service marks of CBRE, Inc. All other marks displayed on this document are the property of their respective owners, and the use of such marks does not imply any affiliation with or endorsement of CBRE. Photos herein are the property of their respective owners. Use of these images without the express written consent of the owner is prohibited.

