

CROSSGATE Center

Lease
Opportunity

355 E Campus View Blvd
Columbus, OH 43235



Christopher Potts, CCIM

☎ +1 614 437 4654

☎ +1 614 296 4529

✉ christopher.potts@colliers.com

Taylor Fanté, CCIM

☎ +1 614 410 5292

☎ +1 740 317 9194

✉ taylor.fante@colliers.com

Colliers

Opportunity

Crossgate Center is an 80,000 SF two-story multi-tenant office building with easy access to I-270, SR-315 and US-23. Building amenities include a recently renovated interior and lobby, an open court yard for tenants' use, as well as a common area conference room and break room.

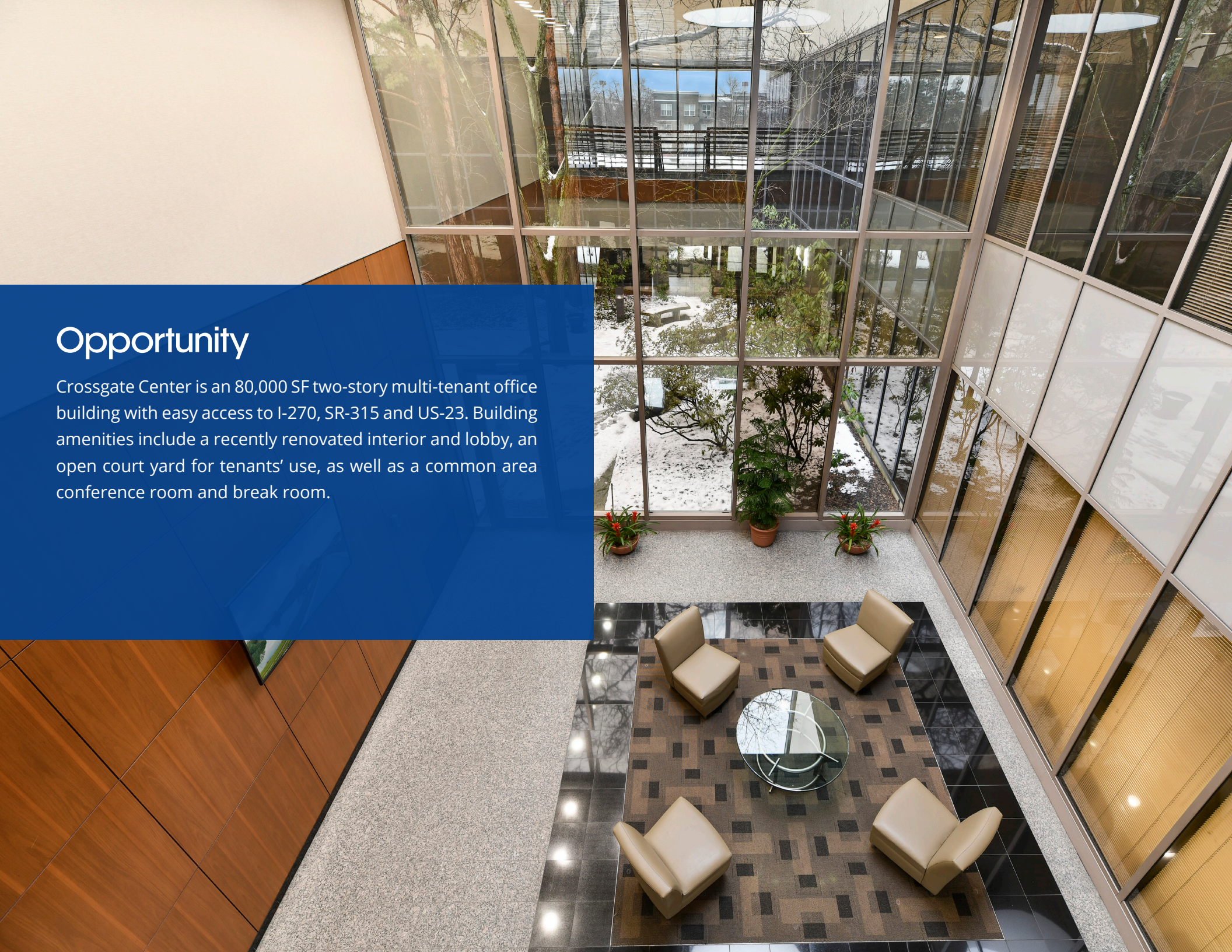



Crossgate Center

Features & Amenities

- Easily accessible from I-270, SR-315 and US-23
- Open area courtyard for tenants' use
- Parking ratio of 4/1,000 SF
- Recently renovated interior and lobby
- Surrounded by numerous hotels and a range of restaurants
- Common area conference room and break room available on the first and second floor





CROSSGATE

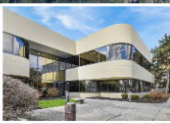

COURTYARD



tropical CAFE

CHASE

FIRST first financial bank

Bank of America

DiBella's Subs

PIZZERIA MADNESS

FIRST WATCH

MAPLE & STREET BISCUIT COMPANY

FIVE GUYS BURGERS and FRIES

Aladdin's

Tanera BREAD

FedEx

EconoLodge

Park NATIONAL BANK

TRUMP STORE

McDonald's

Starbucks

Location

Crossgate Center is located within easy access to several major highways. Hotels, shopping and restaurants are all just minutes away.



Rentable Areas (APPROX)

Suite 130	1,512 SF	Small suite with 3 offices and break room.
Suite 157	1,796 SF	4 private offices and open workspace.
Suite 208	1,964 SF	Move-in ready spec suite complete with conference room, private offices, new carpet, paint, and LED lights.
Suite 247	1,461 SF	Efficient suite with 3 offices, conference and break room.

Basic Lease Rate

\$18.95 FSG

Floor Plans - Crossgate Center

First Floor

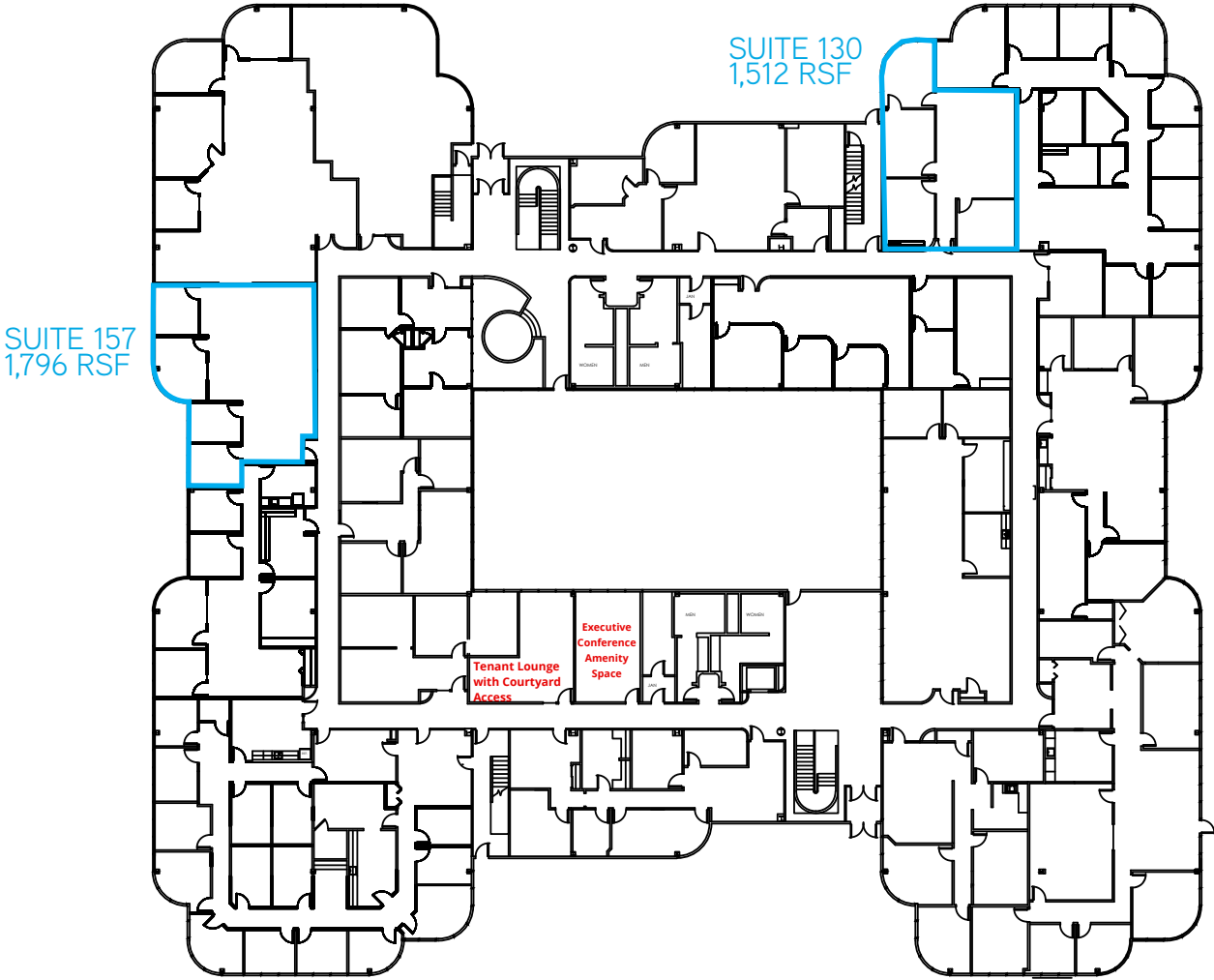

Floor Plans - Crossgate Center

Suite 130 - 1,512 RSF

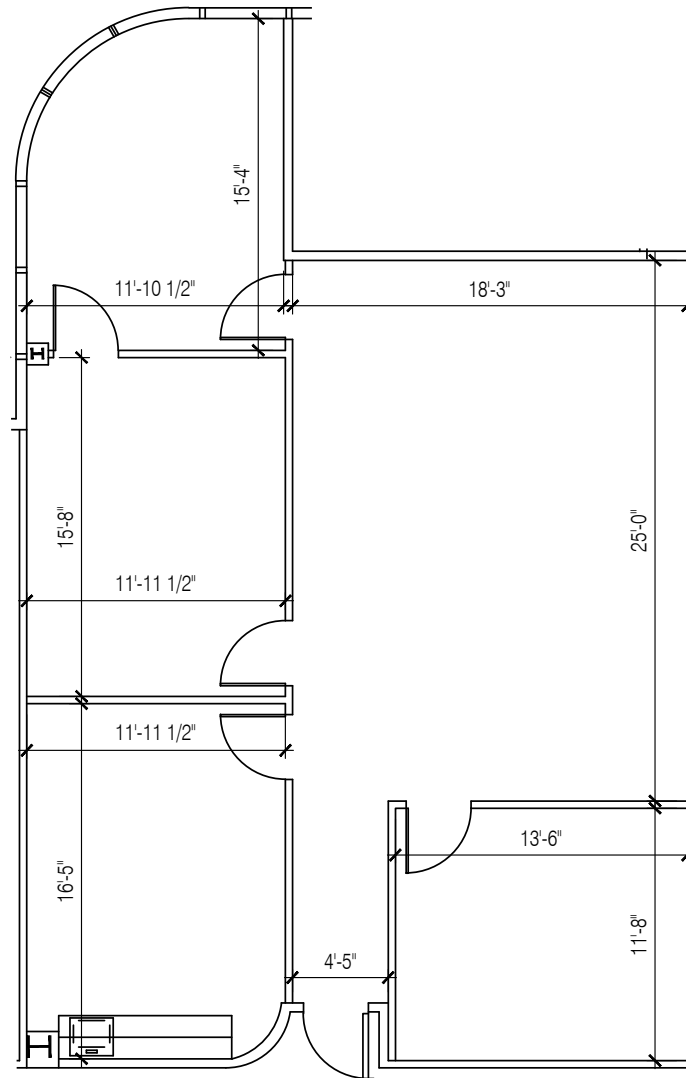

Floor Plans - Crossgate Center

Suite 157 - 1,796 RSF

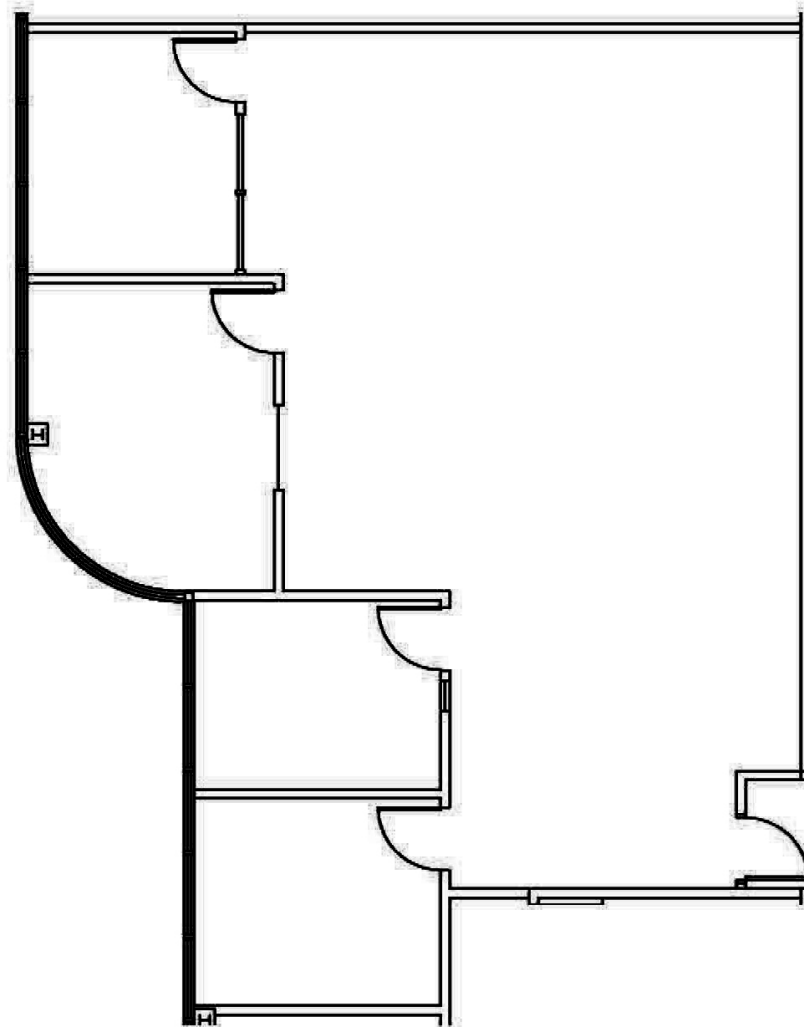

Floor Plans - Crossgate Center

Second Floor

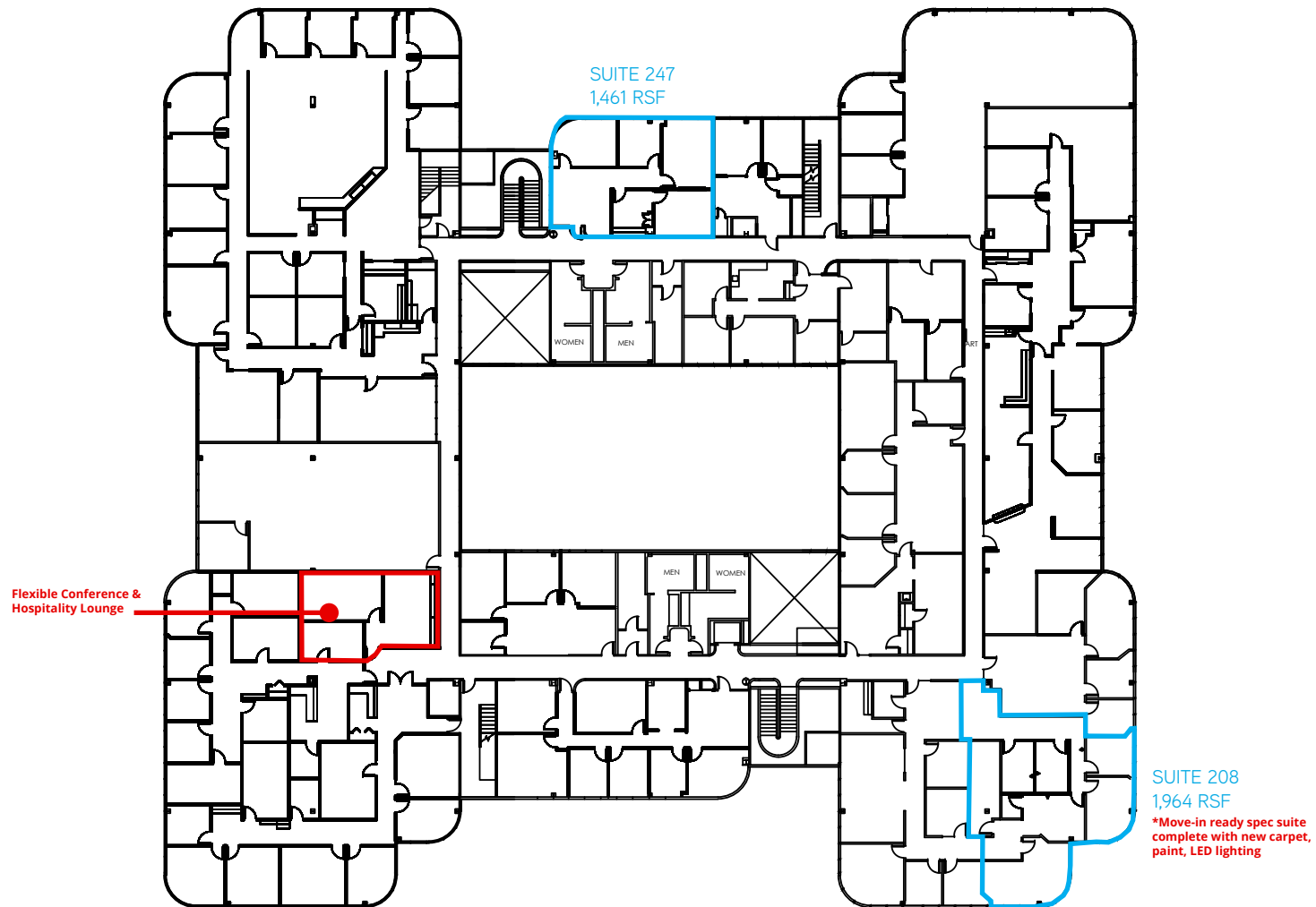

SUITE 208
1,964 RSF
*Move-in ready spec suite
complete with new carpet,
paint, LED lighting

Potential Spec Suite Option 1

Suite 208 - 1,964 RSF

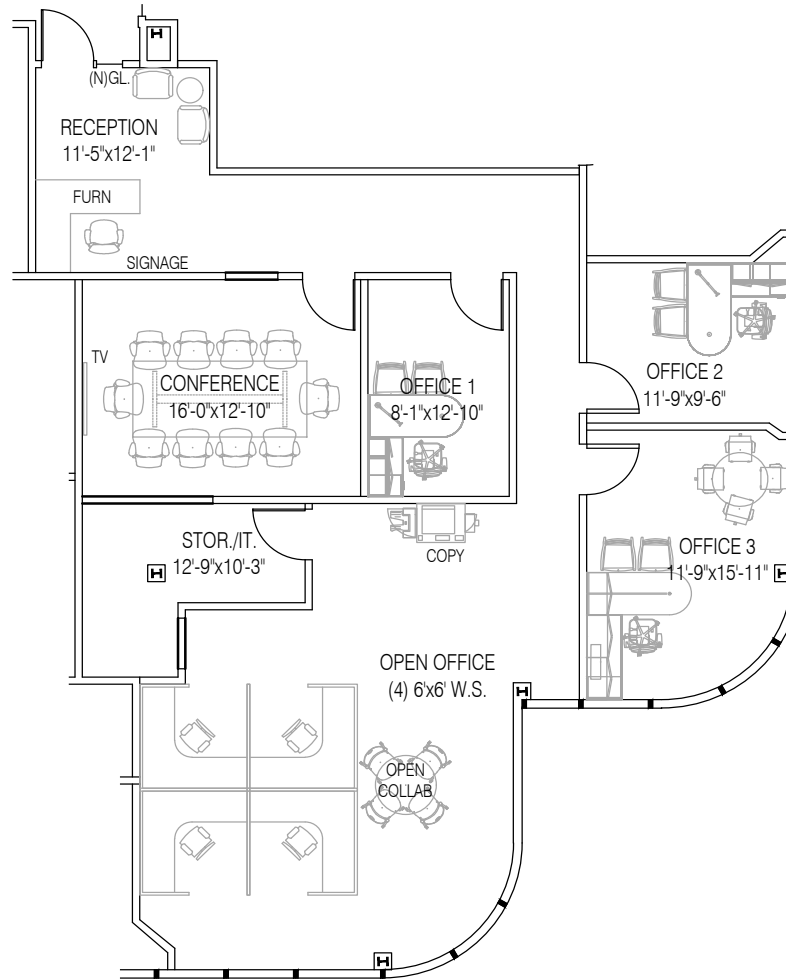

Proposed Plan

N.T.S.

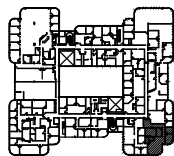

building key plan
Second Floor

N.T.S.

Floor Plans - Crossgate Center

Suite 247 - 1,461 RSF

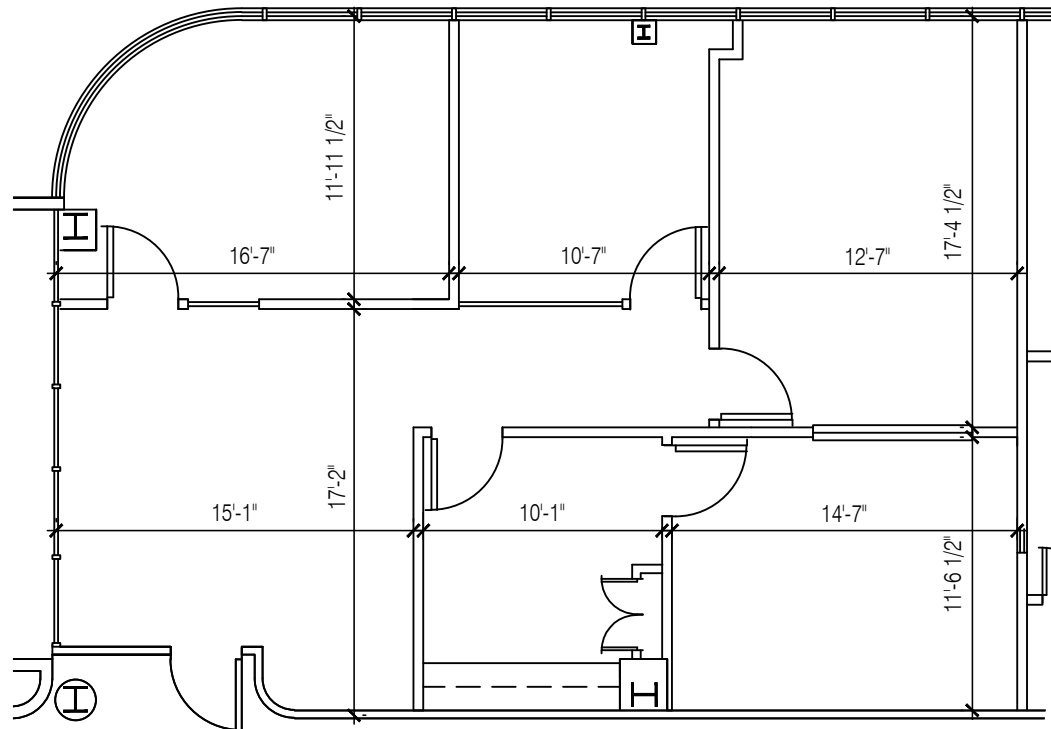

Property Photos



CROSSGATE Center

Colliers

Greater Columbus Region
Two Miranove Place
Suite 900
Columbus, OH 43215

colliers.com/columbus

Christopher Potts, CCIM

+1 614 437 4654

+1 614 296 4529

christopher.potts@colliers.com

Taylor Fanté, CCIM

+1 614 410 5292

+1 740 317 9194

taylor.fante@colliers.com