

**PURCHASER'S INFORMATION BOOKLET**

**For**

**CRYSTAL LAKE STORAGE BARNs**

**A Storage Condominium**

**Township of Benzonia, Benzie County, Michigan**

**Developed By:**

Crystal Lake Storage Barns, LLC  
892 Lodge Pine Lane  
Traverse City, Michigan 49684

# **INDEX OF CONDOMINIUM DOCUMENTS**

**For**

## **CRYSTAL LAKE STORAGE BARNs**

1. Instruction Sheet
2. Acknowledgment and Receipt
3. Master Deed and Exhibits
  - A. Condominium Bylaws
  - B. Subdivision Plans
4. Articles of Incorporation
5. Association Bylaws
6. Escrow Agreement
7. Purchase Agreement
8. Waiver
9. The Condominium Buyers' Handbook



## INSTRUCTION SHEET

### CRYSTAL LAKE STORAGE BARNs

Pursuant to Section 84(a) of the Condominium Act, you, as a prospective purchaser of a unit in this Project, are advised of the following:

**The Developer must provide copies of all of the following documents to a prospective purchaser:**

- A. The recorded Master Deed.
- B. A copy of the Purchase Agreement.
- C. A copy of the Escrow Agreement.
- D. A Condominium Buyers' Handbook.
- E. A Disclosure Statement containing all of the following:
  - 1. An explanation of the Association of Co-owner's possible liability in the event of foreclosure of a first mortgage
  - 2. The names, addresses and previous experience with Condominium Projects of each Developer, and any management agency, real estate broker, residential builder and residential maintenance and alteration contractor.
  - 3. A projected budget for the first year of operation of the Association of Co-owners.
  - 4. An explanation of the escrow arrangement prescribed by the Condominium Act.
  - 5. Any expressed warranties undertaken by the Developer, together with a statement that warranties are not provided unless specifically stated.
  - 6. An identification of all structures and improvements labeled "Need Not Be Built."
  - 7. The extent to which financial arrangements have been provided for completion of all structures and improvements labeled "Must Be Built."
  - 8. Other material information about the Condominium Project and the Developer that the administrator requires by rule.

If you, as a prospective purchaser, have any questions regarding the foregoing, you should direct your questions to the Developer or the real estate broker. Your signature in the place provided below is prima facia evidence that the documents identified above have been received and understood by you.

Dated: \_\_\_\_\_

**PURCHASER:**

\_\_\_\_\_  
\_\_\_\_\_

Unit No.: \_\_\_\_\_



**Acknowledgment of Receipt of Condominium Documents**

For

**CRYSTAL LAKE STORAGE BARNS**

The undersigned hereby acknowledges receipt of a copy of the Condominium documents for **CRYSTAL LAKE STORAGE BARNS** from **Crystal Lake Storage Barns, LLC**, the Developer, including the Disclosure Statement for this Project.

Dated: \_\_\_\_\_

\_\_\_\_\_

\_\_\_\_\_







DocId:8046314

Tx:4033125

7/22/2024 10:30:00 AM

2024-02301

STATE OF MI BENZIE CO  
RECORDED 07/23/2024 09:08 AM

REC FEE: 35.00

PAGE 1 OF 39

PAULA EBERHART  
REGISTER OF DEEDS

**MASTER DEED**

**For**

**CRYSTAL LAKE STORAGE BARNs**

This **MASTER DEED** is made this 2<sup>nd</sup> day of July 2024, by Crystal Lake Storage Barns, LLC, a Michigan limited liability company, of 892 Lodge Pine Lane, Traverse City, MI 49684 (hereinafter referred to as the "Developer");

**WITNESSETH:**

**WHEREAS**, the Developer is the owner of lands herein described and desires to establish the same together with improvements to be located thereon and the appurtenances thereto as a Condominium Project under the provisions of Act 59 of the Public Acts of 1978, as amended, by recording this Master Deed together with the Condominium Bylaws attached hereto as Exhibit "A" and the Condominium Subdivision Plans attached hereto as Exhibit "B", both of which are incorporated herein by reference and made a part hereof.

**NOW, THEREFORE**, the Developer does hereby establish **Crystal Lake Storage Barns** by recording of this Master Deed as a Condominium Project and does declare that **Crystal Lake Storage Barns** (hereinafter referred to as the "Condominium"), shall be henceforth held, conveyed, encumbered, leased, occupied, improved and in any other manner utilized, subject to the provisions of said Act and to the covenants, conditions, restrictions, uses, limits and affirmative obligations set forth in this Master Deed and Exhibits "A" and "B" hereunder, all of which shall be deemed to run with the land. In furtherance of the establishment of said Condominium, it is provided as follows:

**I.**

**TITLE AND NATURE**

The Condominium Project shall be known as **Crystal Lake Storage Barns**, Benzie County Condominium Subdivision Plan No. 92. The Condominium Project is established in accordance with Act 59 of the Public Acts of 1978, as amended. The Bylaws attached hereto as Exhibit "A" are hereby incorporated herein by reference. The Condominium Subdivision Plans attached hereto as Exhibit "B" are hereby incorporated herein by reference.

STATE OF MICHIGAN  
COUNTY OF BENZIE

Beulah, Michigan 7-22-2024

I hereby certify that there are no tax liens or titles held by the state on lands described herein, and that there are no tax Liens or titles held by individuals on said lands for the five years preceding the date of this instrument, as shown by the records of this office. This certification does not apply to taxes, if any now in the process of collection, by township, city or village collecting offices.

Sec 135, Act 206, 1893 as amended, Carla Marie Deputy County Treasurer

## II.

### LEGAL DESCRIPTION

The land on which the Condominium Project is located and which is established by this Master Deed is situated in Township of Benzonia, Benzie County, and State of Michigan, and described as follows, viz:

Part of Lot 4, Block 28, Plat of Village of Benzonia, Benzonia Township, Benzie County, Michigan; more fully described as follows: Commencing at the Southwest corner of said Lot 4; thence along the Northerly Right-Of-Way of South Street S 87°43'24" E a distance of 100.01' (RECORD S 89°06'29" E 100.00') to the Point Of Beginning; thence N 01°18'51" E a distance of 306.40' (RECORD N 00°04'51" E 306.21') to the Northerly line of said Lot 4; thence along said line S 87°52'10" E a distance of 200.11' (RECORD S 89°06'33" E 200.00'); thence continuing along said Northerly line S 87°52'05" E a distance of 135.36' (RECORD S 89°06'33" E 135.39'); thence S 01°23'23" W a distance of 306.17' (RECORD S 00°05'32" W 306.22') to said Northerly Right-Of-Way line of South Street; thence along said line N 87°54'24" W a distance of 335.07' (RECORD N 89°06'29" W 335.33') to the Point of Beginning.

Consisting of 2.36 acres.

Subject to a 33' wide easement for ingress and egress in part of Lot 4, Block 28, Plat of Village of Benzonia, Benzonia Township, Benzie County, Michigan; the exterior of said easement is more fully described as follows: Commencing at the Southwest corner of said Lot 4; thence along the Northerly Right-Of-Way line of South Street S 87°43'24" E a distance of 308.12' (RECORD S 89°06'29" E) to the Point of Beginning; thence N 28°43'00" E a distance of 46.71'; thence N 01°23'23" E a distance of 264.49' to the Northerly line of said Lot 4; thence along said line S 87°52'05" E a distance of 33.00'; thence S 01°23'23" W a distance of 272.08'; thence S 28°43'00" W a distance of 38.19' to said Northerly line of South Street; thence along said line N 87°54'24" W a distance of 36.91' to the Point of Beginning.

Subject to and together with any easements, encroachments and/or restrictions if any.

**THE ABOVE-DESCRIBED PREMISES ARE CONVEYED SUBJECT TO THE RESTRICTIVE COVENANTS STATED HEREINAFTER.**

**All oil, gas and mineral rights, to the extent not previously severed from the above described property, are hereby reserved to the Developer.**

### III.

#### DEFINITIONS

A. The following terms, whenever utilized in this Master Deed, Condominium Bylaws, Articles of Incorporation, Bylaws of Association of Co-owners, Purchase Agreement, instruments of conveyance including amendments to Master Deed and consolidating Master Deed, and in any other document or instrument without limitation shall be defined as follows:

1. **The Act** means the Michigan Condominium Act, being Act No. 59 of the Public Acts of 1978 as amended.
2. **Association** shall mean the entity designated in the Condominium documents to administer the Condominium Project.
3. **Common Elements** where used without modification shall mean both the general and limited common elements described in Article IV hereafter.
4. **Condominium Bylaws** means Exhibit "A" hereto, being the Bylaws setting forth the substantive rights and obligations of the Co-owners and required by the Act to be recorded as part of the Master Deed.
5. **Condominium Documents** wherever used means and includes this Master Deed and Exhibits "A" and "B" hereto, the Articles of Incorporation, Bylaws and the Rules and Regulations, if any, of the Association.
6. **Condominium Premises** means and includes the land and the buildings, all improvements and structures thereof, and all easements, rights and appurtenances belonging to the Condominium Project and described in Article II above.
7. **Condominium Project, Condominium or Project** means **Crystal Lake Storage Barns** as a Condominium Project established in conformity with the provisions of the Act.
8. **Condominium Subdivision Plan** means Exhibit "B" hereto.
9. **Consolidating Master Deed** means the final amended Master Deed which shall describe the Condominium as a completed Condominium Project and shall reflect the entire land area, and all Units and common elements therein, and which shall express percentages of value pertinent to each Unit as finally readjusted. Such consolidating Master Deed, when recorded in the office of the Benzie County Register of Deeds, shall supersede any previously recorded Master Deed for the Condominium.
10. **Co-owner** means a person, firm, corporation, partnership, association, trust or other legal entity or any combination thereof who or which owns one or more Units in

the Condominium Project. A land contract vendee of a Unit in this Project shall be the Co-owner for all purposes relating to the Project. The term "owner," wherever used, shall be synonymous with the term "Co-owner".

11. **Developer** means Crystal Lake Storage Barns, LLC, and its assigns.
12. **Percentage of Value** means the percentage assigned to each individual Condominium Unit in the Master Deed.
13. **Transitional Control Date** shall mean the date on which a Board of Directors of the Association takes office pursuant to an election in which the votes which may be cast by non-Developer Co-owners exceeds the votes which may be cast by the Developer.
14. **Unit** shall each mean the enclosed space constituting a single complete storage Unit in the Condominium as such space may be described on Exhibit "B" hereto, and shall have the same meaning as the term "Unit" is defined in the Act.

B. Terms not defined herein, but defined in the Act, shall carry the meaning given them in the Act unless the context clearly indicates to the contrary. Whenever any reference herein is made to one gender, the same shall include a reference to any and all genders where the same would be appropriate; similarly, whenever a reference is made herein to the singular, a reference shall also be included to the plural where the same would be appropriate.

C. The provisions of this Master Deed as well as those of the Articles of Incorporation, Bylaws and any rules and regulations of the Association shall be interpreted by Developer, unless Developer ceases to exist, in which case they shall be interpreted by the Board of Directors. Any such interpretation of the Board which is rendered in good faith shall be final, binding and conclusive if the Board receives a written opinion of legal counsel of the Association, or the counsel having drafted this Master Deed or other applicable document, that the interpretation is reasonable, which opinion may be rendered before or after the interpretation is adopted by the Board. Notwithstanding any rule of law to the contrary, the provisions of this Master Deed and the Articles, Bylaws and Rules and Regulations of the Association shall be liberally construed so as to effectuate the purposes herein expressed with respect to the efficient operation of the Association and the Properties, the preservation of the values of the Units and the protection of the Developer's rights, benefits and privileges herein contemplated.

#### IV.

#### **COMMON ELEMENTS**

A. The common elements of the Project and the respective responsibilities for maintenance, decoration, repair or replacement thereof, are as follows:

1. **General Common Elements**. The General Common Elements are:
  - a. **Land**. The land and other Common Areas as described in Article II and

which are not identified as Units or Limited Common Elements, including drives, roads, open spaces and paved services.

- b. Construction. Foundations, exterior walls, supporting columns, perimeter walls and roofs.
- c. Electrical. The electrical transmission system throughout the Project, including ports within Unit walls up to the point of connection with any utility meter.
- d. Exterior Lighting. The exterior lighting throughout the Project, including all electrical transmission lines, fixtures and related equipment (but specifically excluding any Limited Common Elements identified in Section 2, below).
- e. Water. The water distribution system throughout the Condominium Project from the service shut-off at the property boundary line of the Condominium Project, including any yard hydrants or related ancillary equipment, up to the shut-off for individual Unit service is a General Common Element.
- f. Sanitary Sewer. The sanitary sewer system throughout the Condominium Project is a General Common Element from the service shut-off at the property boundary line of the Condominium Project, including any and all tanks, pumps, piping, valves, wiring, equipment and controls, up to the point which it branches into a lateral connection for individual building and Unit service as a Limited Common Element.
- g. Storm Sewer. The storm sewer system throughout the Condominium Project, including grates, catch basins, manholes, pipes, mains, storm water treatment facilities and outfall structures is a General Common Element.
- i. Other. Such other elements of the Project not herein designated as General or Limited Common Elements which are not enclosed within the boundaries of a Unit, and which are intended for common use or are necessary to the existence, upkeep and safety of the Project.

Some or all of the utility lines, systems (including mains and service leads) and equipment described above may be owned by the local public authority or by the company that is providing the pertinent service. Accordingly, such utility lines, systems and equipment, if any, and the Developer makes no warranty whatsoever with respect to the nature or extent of such interest, if any.

- 2. Limited Common Elements. Limited Common Elements shall be subject to the exclusive use and enjoyment of the Owner of the Unit to which the Limited Common Elements are appurtenant. The Limited Common Elements for Units are:

- a. Entry Drive. The entry drive in front of each Unit shall be a Limited Common Element appurtenant to the Unit it serves.
  - b. Electrical. The electrical systems in the buildings up to the point of connection to any electrical meter, and including electrical fixtures, plugs and switches within, or outside of, any Unit are Limited Common Elements appurtenant to the Units including lighting operated from within any Unit or metered to the Unit.
  - c. Exterior Lighting. Any exterior lighting related to or operated from a Unit, including electrical transmission lines, fixtures and related equipment, is a Limited Common Element appurtenant to the Unit including lighting and outlets operated from within any Unit or metered to the Unit.
  - d. Gas. The gas distribution system contained within building or Unit walls from the gas meters and including connection with any gas fixtures are Limited Common Elements appurtenant to the Unit.
  - e. Water. The water distribution system from the point of the shut off for individual Unit service is a Limited Common Element appurtenant to the Unit.
  - f. Sanitary Sewer. The sanitary sewer system from the point at which a lateral connection or lead branches to serve an individual Unit is a Limited Common Element appurtenant to the Unit.
  - g. Interior Surfaces. The interior surfaces of the Unit and storage area perimeter walls, windows, doors, ceilings and floors contained within a Unit, shall be subject to the exclusive use and enjoyment of the Co-Owner of such Unit.
  - h. Floor. The slab floor in each Unit, if installed by the Developer or Unit owner, shall be a Limited Common Element appurtenant to the Unit it serves.
  - i. Doors. All doors and related equipment shall be a Limited Common Element appurtenant to the Unit it serves.
3. Responsibilities. The respective responsibilities for the maintenance, decoration, repair and replacement of the Common Elements are set forth below.
- a. Common Elements. With respect to all Units, the responsibilities are set forth below.
    - (i) Association Responsibilities. The General Common Elements

described in Article IV(A)(1) and Limited Common Elements described in Article IV(A)(2)(a), shall be maintained, repaired and replaced by the Association.

(ii) Co-Owner Responsibilities. The Limited Common Elements appurtenant to the Units described in Article IV(A)(2), subsections (b) through (i) shall be repaired, replaced and maintained by the Co-Owner(s) of the Unit(s) to which they are appurtenant.

- b. Additional Charges. Consistent with Section 69 of the Act, the Association may specially assess to any Co-Owner(s) the cost of maintenance, repair, replacement and insurance (and any other cost) associated with any Limited Common Elements assigned to a Unit. Any unusual expenses incurred as a result of the conduct of less than all those entitled to occupy the Condominium Project may be specially assessed against the Unit or Units involved at the Board of Directors' discretion.
- c. Co-Owner Maintenance, Repair or Replacement of Limited Common Elements. A Co-Owner may, in the discretion of the Board of Directors, undertake maintenance, repair or replacement of a General Common Element instead of having that task undertaken by the Association. In that event, the expense of such maintenance, repair or replacement shall be borne by the Co-Owner(s) undertaking the work. All work must be done according to sound industry standards and subject to limitations and requirements approved by the Board of Directors of the Association.
- d. Approvals Needed. All Co-Owner work under this Article IV(A)(3) is subject to the prior approval of the Association in its sole discretion. All work must be done according to sound industry standards and subject to limitations and requirements approved by the Board of Directors of the Association.
- e. Other. The costs of maintenance, repair and replacement of all General and Limited Common Elements other than as described above shall be borne by the Association, subject to any provisions of the Bylaws expressly to the contrary.

B. No Co-Owner shall use his or her Unit or the Common Elements in any manner inconsistent with the purposes of the Project or in any manner which will interfere with or impair the rights of any other Co-Owner in the use and enjoyment of his or her Unit or the Common Elements.

V.

**UNIT DESCRIPTION AND PERCENTAGE OF VALUE**

A. Each Unit in the Project is described in this paragraph with reference to the Subdivision and Site Plan of the Project attached hereto as Exhibit "B." Each Unit shall include all that space contained within the interior finished unpainted walls and ceilings and from the dirt floor (or slab floor if installed by the Unit owner or Developer) as shown on the floor plan sheet on Exhibit "B" hereto.

B. The Percentage of Value assigned to each Unit is set forth in subparagraph D below. The Percentage of Value assigned to each Unit shall be determinative of the proportionate share of each respective Co-owner in the expenses and proceeds of administration of the Association and Common Elements of the Condominium. Each respective Co-owner shall have one (1) vote at meetings of the Association. The total value of the Project is one hundred percent (100%). The Percentage of Value allocated to each Unit may be changed only with the unanimous consent of all of the Co-owners expressed in an amendment to this Master Deed, duly approved and recorded, except as provided hereafter.

C. The determination of the Percentage of Value which should be assigned was made after reviewing the comparative characteristics of each Unit in the Project and concluding that the Percentage of Value assigned to each Unit should be based on their square footage with an equitable adjustment for burdens on the Common Elements as determined by the Developer.

D. The Percentage of Value assigned to each Unit shall be as follows:

Unit	Percentage (%) of Value
1	4
2	4
3	4
4	4
5	4
6	4
7	4
8	4
9	4
10	4
11	5
12	5
13	4
14	4
15	4
16	4
17	4
18	3
19	3



20	3
21	3
22	3
23	3
24	3
25	3
26	3
27	3

**VI.**

**EASEMENTS**

In the event any portion of a Unit or Common Element encroaches upon another Unit or Common Element due to shifting, settling or moving of a building, or due to survey errors, or construction deviations, reciprocal easements shall exist for the maintenance of such encroachment for so long as such encroachment exists, and for maintenance thereof after rebuilding in the event of any destruction. There shall be easements to, through and over those portions of the land, structures, buildings, improvements and walls (including interior Unit walls) contained therein for the continuing maintenance and repair of all utilities in the Condominium. There shall exist easements of support with respect to any Unit interior wall which supports a Common Element.

**VII.**

**EASEMENTS RETAINED BY DEVELOPER**

A. The Developer reserves for the benefit of itself, its successors and assigns, perpetual easements for the unrestricted use of all roads, driveways and walkways in the Condominium for the purposes of ingress and egress to and from all or any portion of the parcel described in Article II or any portion or portions thereof, and any other land contiguous to the Condominium premises which may be now owned or hereafter acquired by the Developer or its successors.

B. The Developer also hereby reserves for the benefit of itself, its successors and assigns, and all future owners of the land described in Article II or any portion or portions thereof and any other land contiguous to the Condominium premises which may be now owned or hereafter acquired by the Developer, perpetual easements to utilize, tap and tie into all utility mains located on the Condominium premises.

C. The Developer reserves to itself, its successors and assigns, the right to terminate and revoke any utility or other easements granted in Exhibit "B" at such time as the particular easement has become unnecessary. This may occur by way of example but not limitation when water or sewer systems are connected to municipal systems. No easement utility may be terminated or revoked unless and until all Units served by it are adequately served by an appropriate substitute or replacement utility. Any termination or revocation of any such easement shall be effected by

the recordation of an appropriate amendment to this Master Deed.

D. In addition to the rights reserved to the Developer elsewhere in the Condominium Documents, the Developer reserves exclusively, for the benefit of itself and its assigns, an easement and the right to grant such easements, licenses and other rights of entry, and to enter into any contract agreement, including wiring agreements, right-of-way agreements, and to the extent allowed by law, contracts for sharing of any installation or periodic subscriber service fees as may be necessary, convenient or desirable to provide for telecommunication systems to be installed on the Project whether or not they are for the benefit of the Project or any Unit. Notwithstanding anything herein to the contrary Developer and its assigns shall have the exclusive right to install communication devices and telecommunication systems on the Project and all related equipment, including without limitation, satellite dishes, antenna and wiring. Developer may exercise such rights without permission of the Association or any other party. Any sums paid by any telecommunication supplier or other entity in connection with such rights and services, including fees, if any, for the privilege of installing any telecommunication system or sharing periodic subscriber service fees, shall be the sole property of the Developer.

#### VIII.

#### SUBDIVISION OF UNITS

The Developer reserves the right to subdivide Units in accordance with this section. If the Developer wishes to subdivide any Unit, then the Developer shall prepare and execute an amendment to the Master Deed duly subdividing the Unit. The amendment to the Master Deed shall assign new identifying numbers to the new Units created by the subdivision of a Unit and shall allocate to those Units, on a reasonable basis, all of the undivided interest in the Common Elements appertaining to the subdivided Unit. The new Units shall jointly share all rights, and shall be equally liable, jointly and severally for all obligations, with regard to any Limited Common Elements assigned to the subdivided Unit except to the extent that an amendment shall provide that portions of any Limited Common Element assigned to the subdivided Unit exclusively should be assigned to any, but less than all, of the new Units. An amendment to the Bylaws shall allocate to the new Units, on a reasonable basis, the votes in the Association of Co-owners allocated to the subdivided Unit, and shall reflect a proportionate allocation to the new Units of the liability for expenses of administration and rights to receipts of administration formerly appertaining to the subdivided Unit.

#### IX.

#### CONTRACTION OF CONDOMINIUM

A. The Condominium Project is a contractible condominium project, as that term is defined in the Act. The Condominium Project established pursuant to this initial Master Deed, and consisting of twenty-seven (27) Units, may be contracted so as to include as few as five (5) Units.

The Developer, for itself and its successors and assigns, hereby explicitly reserves the right to contract the Condominium Project without the consent of any of the Co-owners. This right may

be exercised without any limitations whatsoever, except as expressly provided in this Article IX. The Developer reserves the right to divide and assign common elements at its sole discretion.

B. Restrictions Upon Contraction. Contraction of the Condominium Project shall occur without restriction under the following conditions:

1. The Developer's right to elect to contract the project shall expire on that date six (6) years after the date of the initial recording of this Master Deed.
2. All contraction must be carried out in accordance with the provisions of the Act.

## X.

### AMENDMENT

A. The Condominium Documents may be amended for a proper purpose, without consent of Co-owners, mortgagees and other interested parties, including the modification of the types and sizes of Units prior to construction of Units and unsold Condominium Units and their appurtenant Limited Common Elements, as long as the amendments do not materially alter or change the rights of the Co-owners, mortgagees or other interested parties. This includes amendments which in the written opinion of a licensed real estate appraiser, do not detrimentally change the value of the Unit.

B. The Condominium Documents may be amended for a proper purpose, even if the amendment will materially alter or change the rights of the Co-owners, mortgagees or other interested parties with the approval of two-thirds (2/3) of the votes of the Co-owners entitled to vote and mortgagees. A Co-owner's Condominium Unit dimensions or appurtenant Limited Common Elements may not be modified without his consent. Co-owners and mortgagees of record shall be notified of proposed amendments. Mortgagees may be notified of proposed amendments and approve same by written ballot. Ballots not returned within ninety (90) days shall be deemed approved.

C. A person causing or requesting an amendment to the Condominium Documents shall be responsible for costs and expenses of the amendment except for amendments based upon a vote of a prescribed majority of Co-owners or based upon the Association Board of Director's decision, the costs of which are expenses of administration.

D. Notwithstanding any contrary provision of this Master Deed or the Condominium Bylaws, the Developer reserves the right, pursuant to and subject to Section 90(3) of the Condominium Act, to amend materially this Master Deed or any of its exhibits (including, without limitation, documents referred to herein or in the Bylaws which affect the rights and obligations of a Co-owner) to achieve the following specified purposes:

1. to modify the types and sizes of unsold Condominium Units and their appurtenant limited common elements and/or percentages of value;

2. to amend the Condominium Bylaws;
3. to correct arithmetic errors, typographical errors, surveying or planning errors, deviations in construction, or any similar errors in the Master Deed, Condominium Subdivision Plan, or Condominium Bylaws, or to correct errors in the boundaries or locations of improvements;
4. to clarify or explain the provisions of the Master Deed or its exhibits;
5. to comply with the Act or rules promulgated thereunder or with any requirements of any governmental or quasi-governmental agency;
6. to make, define, or limit easements affecting the Condominium premises;
7. to record an "as-built" Condominium subdivision plan; and
8. to facilitate mortgage loan financing for existing or prospective co-owners and to enable the purchase of insurance of such mortgage loans by any institutional participant in a secondary mortgage market which purchases or insures mortgages.

E. A Master Deed Amendment, including the Consolidating Master Deed, dealing with the addition or modification of Units or the physical characteristics of the Project shall comply with the standards prescribed in the Act for preparation of an original Condominium.

F. Any amendment to this Master Deed, Condominium Bylaws and Exhibit "B" documents which effect the use, structures or any improvements located within this Project, shall always be subject to the applicable ordinances of Benzonia Township and submitted to the Township for prior approval.

G. Notwithstanding anything to the contrary contained in this Master Deed or its exhibits, for so long as the Developer owns one or more Units in the Project, no amendment shall be made to the Condominium Documents without the prior written consent of the Developer.

## XI.

### ASSIGNMENT

Any or all of the rights and powers granted or reserved to the Developer in the Condominium Documents or by law (including the power to approve or disapprove any act, use or proposed action or any other matter or thing) may be assigned by it to any other entity or to the Association. Any such assignment or transfer shall be made by appropriate instrument in writing duly recorded in the office of the Benzie County Register of Deeds.

**IN WITNESS WHEREOF**, the Developer has caused this Master Deed to be executed the day and year first above written.

**DEVELOPER:**

**Crystal Lake Storage Barns, LLC,**  
a Michigan limited liability company

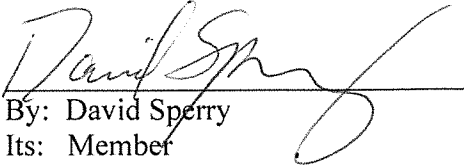
  
By: David Sperry  
Its: Member

STATE OF MICHIGAN )  
COUNTY OF Grand Traverse ) ss.

Acknowledged on the 2<sup>nd</sup> day of July 2024, before me personally appeared David Sperry, a Member of Crystal Lake Storage Barns, LLC, a Michigan limited liability company, the organization described in and which executed the foregoing instrument, and that he signed his name thereto as and for his voluntary act and deed and as and for the voluntary act and deed of said organization.

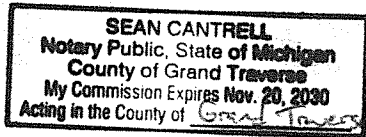

  
\_\_\_\_\_, Notary Public  
\_\_\_\_\_, County, MI  
Acting in \_\_\_\_\_ County, MI  
My Commission Expires: \_\_\_\_\_

**Prepared by/Return to:**  
David H. Rowe, Esq.  
*Alward, Fisher, Rice, Rowe & Graf, PLC*  
412 S. Union Street  
Traverse City, Michigan 49684  
(231) 346-5400

W:\Crystal Lake Storage Barns LLC\Crystal Lake Storage Barns\Master Deed 7-2-2024.docx

## CONDOMINIUM BYLAWS – EXHIBIT “A” TO MASTER DEED

### CRYSTAL LAKE STORAGE BARNs

#### ARTICLE I

#### ASSOCIATION OF CO-OWNERS

A. **Crystal Lake Storage Barns**, a storage Condominium Project located in Township of Benzonia, Benzie County, State of Michigan, shall be administered by an Association of Co-owners, which shall be a non-profit corporation (hereinafter called the "Association") organized under the laws of the State of Michigan.

B. The Association shall be organized to manage, maintain and operate the Condominium in accordance with the Master Deed, these Bylaws, the Articles of Incorporation and Bylaws of the Association and the laws of the State of Michigan. The Association shall be responsible for the management and administration of the Common Elements, property, easements and affairs of the Condominium Project. The Association may provide for independent management of the Condominium Project.

C. Membership in the Association and voting by the members of the Association shall be in accordance with the following provisions:

1. Each Co-owner shall be a member of the Association and no other person or entity shall be entitled to membership.
2. The share of a Co-owner in the funds and assets of the Association cannot be assigned, pledged or transferred in any manner except as an appurtenance to his Unit in the Condominium.
3. Except as limited in these Bylaws, each Co-owner shall be entitled to one (1) vote for each Condominium Unit owned when voting by number and one (1) vote, the value of which shall equal the total of the percentages allocated to the Unit owned by such co-owner as set forth in Article V of the Master Deed, when voting by value. Voting shall be by number except in those instances when voting is specifically required to be in value.
4. No Co-owner, other than the Developer, shall be entitled to vote at any meeting of the Association until he has presented evidence of ownership of a Unit in the Condominium Project to the Association. No Co-owner, other than the Developer, shall be entitled to vote prior to the First Annual Meeting of Members held in accordance with Paragraph H of this Article I. The vote of each Co-owner may only be cast by the individual representative designated by such Co-owner in the notice required in Paragraph 5 below or by a proxy given by such individual

representative. The Developer shall be entitled to vote each Unit which it owns. Notwithstanding anything herein to the contrary, a purchaser of a Unit by means of a land contract shall be designated the owner of that Unit and entitled to the vote for that Unit.

5. Each Co-owner shall file a written notice with the Association, designating the individual representative who shall vote at meetings of the Association and receive all notices and other communications from the Association on behalf of such Co-owner. Such notice shall state the name, address and email address of each person, firm, corporation, partnership, association, trust or other entity who is the Co-owner. Such notice shall be signed and dated by the Co-owner. The individual representative designated may be changed by the Co-owner at any time by filing a new notice in the manner herein provided.
6. There shall be an annual meeting of the members of the Association commencing with the First Annual Meeting held as provided in Paragraph H of this Article I. Other meetings may be provided for in the Bylaws of the Association. Notice of the time, place and subject matter of all meetings shall be given to each Co-owner by mailing or electronic transmission the same to each individual representative designated by the respective Co-owner at least ten (10) days prior to said meeting.
7. The presence, in person or by proxy, of one-fifth (1/5) of the Co-owners in number and in value shall constitute a quorum for holding a meeting of the members of the Association, except for voting on questions specifically required to require a greater quorum. The written or electronic vote of any person furnished at or prior to any duly called meeting, at which meeting said person is not otherwise present in person or by proxy shall be counted in determining the presence of a quorum with respect to the question upon which a vote is cast.
8. Votes may be cast in person or by proxy or by writing, duly signed by the designated voting representative not present at a given meeting in person or by proxy or by electronic means, subject to the discretion of the Board of Directors. Proxies and any written vote must be filed with the secretary of the Association at or before the appointed time of each meeting of the members of the Association. Cumulative voting shall not be permitted.
9. A majority, except where otherwise provided herein, shall consist of more than fifty percent (50%) in value of those qualified to vote and present in person or by proxy (or written vote, if applicable) at a given meeting of the members of the Association. Whenever provided specifically herein, a majority may be required to exceed the simple majority herein above set forth and may require such majority to be one of both number and value of designated voting representatives present in person or by proxy, or by written ballot, if applicable, at a given meeting of the members of the Association.

10. Any action which may be taken at a meeting of the Co-owners (except for the election or removal of Directors) may be taken without a meeting by written ballot of the members. Ballots will be solicited in the same manner as provided above for the giving of notice of regular meetings of Members. Such solicitations will specify (a) the number of responses needed to meet the quorum requirements; (b) the percentage of approvals necessary to approve the action; and (c) the time by which ballots must be received in order to be counted. The form of written ballot will afford an opportunity to specify a choice between approval and disapproval of each matter and will provide that, where the member specifies a choice, the vote will be cast in accordance therewith. Approval by written ballot will be constituted by receipt within the time period specified in the solicitation of (i) a number of ballots which equals or exceeds the quorum which would be required if the action were taken at a meeting; and (ii) a number of approvals which equals or exceeds the number of votes which would be required for approval if the action were taken at a meeting at which the total number of votes cast was the same as the total number of ballots cast.

D. The Association shall keep detailed books of account showing all expenditures and receipts of administration which shall specify the maintenance and repair expenses of the Common Elements and any other expenses incurred by or on behalf of the Association and the Co-owners. The Association shall prepare and distribute to each Co-owner at least once a year financial statement, the contents of which shall be defined by the Association. Such accounts books, records, contracts, and financial statements concerning the administration and operation of the Condominium Project shall be available for examination by any of the Co-owners and their mortgagees at convenient times. If the Association's annual revenues are greater than \$20,000.00, then on an annual basis the Association shall have its books, records, and financial statements independently audited or reviewed at the discretion of the Board of Directors by a certified public accountant, as defined in section 720 of the occupational code, 1980 PA 299, MCL 339.720. The audit or review shall be performed in accordance with the statements on auditing standards or the statements on standards for accounting and review services, respectively, of the American Institute of Certified Public Accountants. The Association may opt out of this requirement on an annual basis by an affirmative vote of a majority of the Co-owners. The accounting expenses shall be expenses of administration. The Association also shall maintain on file current copies of the Master Deed for the Project, any amendments thereto and all other Condominium Documents, and shall permit all Co-owners, prospective purchasers and prospective mortgagees interested in the Project, to inspect the same during reasonable hours.

E. The affairs of the Association shall be governed by a Board of Directors, all of whom shall serve without compensation and who must be members of the Association, except for the first Board of Directors designated in the Articles of Incorporation of the Association and any successors thereto elected by the Developer prior to the First Annual Meeting of the members.

F. The Association Bylaws shall provide the designation, number, terms of office, qualifications, manner of election, duties, removal and replacement of the officers of the Association and may contain any other provisions pertinent to officers of the Association in furtherance of the provisions and purposes of the Condominium Documents and not inconsistent



therewith. Officers may be compensated, but only upon the affirmative vote of more than sixty percent (60%) of all Co-owners in number and in value.

G. Every director and every officer of the Corporation shall be indemnified by the Association against all expenses and liabilities, including counsel fees, reasonably incurred by or imposed upon him in connection with any proceeding to which he may be a party, or in which he may become involved, by reason of his being or having been a director or officer when expenses are incurred, except in such cases wherein the director or officer is adjudged guilty of willful or wanton misconduct or gross negligence in the performance of his duties; provided that, in the event of any claim for reimbursement or indemnification hereunder based upon a settlement by the director or officer seeking reimbursement or indemnification, the indemnification herein shall apply only if the Board of Directors (with the directors seeking reimbursement abstaining) approves such settlement and reimbursement as being in the best interest of the Association. The foregoing right of indemnification shall be in addition to and not exclusive of all other rights to which such director or officer may be entitled. At least ten (10) days prior to payment of any indemnification which it has approved, the Board of Directors shall notify all Co-owners thereof.

H. The First Annual Meeting of the members of the Association may be convened by the Board of Directors and may be called at any time after conveyance of legal or equitable title to a Unit to a non-Developer Co-owner but in no event later than fifty-four (54) months after such event. The date, time and place of such First Annual Meeting shall be set by the Board of Directors, and at least ten (10) days written or electronic notice thereof shall be given to each Co-owner. Thereafter, an annual meeting shall be held each year on such date as is specified in the Association Bylaws. The Board of Directors shall establish an Advisory Committee of non-Developer members upon the passage of: (a) one hundred twenty (120) days after legal or equitable title to one-third (1/3) of the Condominium Units has been conveyed to non-Developer Co-owners; or (b) one (1) year after the first conveyance of legal or equitable title to a Condominium Unit to a non-Developer Co-owner, whichever first occurs. The Advisory Committee shall meet with the Board of Directors to facilitate communication with the non-Developer members and to aid in transferring control from the Developer to non-Developer members. The Advisory Committee shall be composed of not less than one (1) nor more than three (3) non-Developer members, who shall be appointed by the Board of Directors in any manner it selects, and who shall serve at the pleasure of the Board of Directors. The Advisory Committee shall automatically dissolve after a majority of the Board of Directors is comprised of non-Developer Co-owners. Reasonable notice of such meetings shall be provided to all members of the Committee, and such meetings may be open or closed, in the discretion of the Board of Directors.

I. Not later than one hundred twenty (120) days after the conveyance of legal or equitable title to non-Developer Co-owners of twenty-five percent (25%) of the Units that may be created, at least one (1) Director and at least one-fourth (1/4) of the Board of Directors of the Association shall be elected by non-Developer Co-owners. Not later than one hundred twenty (120) days after the conveyance of legal or equitable title to non-Developer Co-owners of fifty percent (50%) of the Units that may be created, at least one-third (1/3) of the Board of Directors shall be elected by non-Developer Co-owners. Not later than one hundred twenty (120) days after the conveyance of legal or equitable title to non-Developer Co-owners of seventy-five percent (75%) of the Units, the non-Developer Co-owners shall elect all Directors on the Board except that the Developer may

designate at least one (1) Director as long as the Developer owns or offers for sale at least ten percent (10%) of the Units in the Project or as long as ten percent (10%) of the Units that may be created remain unbuilt.

Notwithstanding the formula provided above, fifty-four (54) months after the first conveyance of legal or equitable title to a non-Developer Co-owner of a Unit in the Project, if title to at least seventy-five percent (75%) of the Units that may be created has not been conveyed, the non-Developer Co-owners may elect the number of Members of the Board of Directors of the Association equal to the percentage of Units they hold, and the Developer may elect the number of Members of the Board equal to the percentage of Units that it owns and pays assessments for. This election may increase but not reduce the minimum election and designation rights otherwise established in these Bylaws. The application of this provision does not require a change in the size of the Board as stated in the Association Bylaws.

If the calculation of the percentage of Members of the Board that the non-Developer Co-owners may elect or if the product of the number of Members of the Board multiplied by the percentage of Units held by the non-Developer Co-owners results in a right of non-Developer co-owners to elect a fractional number of Members of the Board, a fractional election right of zero point five (0.5) or more shall be rounded up to the nearest whole number, which shall be the number of Members of the Board that the non-Developer Co-owners may elect. After applying this formula, the Developer may elect the remaining Members of the Board. The application of this provision shall not eliminate the right of the Developer to designate at least one (1) Member, as provided in these Bylaws.

J. The Board of Directors may employ, at a compensation established by it, a managing agent for the Condominium to perform such duties and services as the Board shall authorize, including, but not limited to, the powers and duties set forth in this Article. Any director, the Developer, or any related person or entity, may serve as managing agent if so appointed. If the Board employs a professional management agent for the Association, the Board shall notify each holder of a mortgage lien on any Condominium Unit prior to terminating the employment of such professional management agent (or any successor thereto) and assuming self-management. In no event shall the Board be authorized to enter into a contract with a professional management agent, or a contract providing for services by the Developer or its affiliates, which is not terminable by the Association upon the Transitional Control Date or within ninety (90) days thereafter and upon thirty (30) days' written notice for cause. Upon the Transitional Control Date, or within ninety (90) days thereafter, the Board of Directors may terminate a service or management contract with the Developer or its affiliates. In addition, the Board of Directors may terminate any management contract which extends beyond one (1) year after the Transitional Control Date by providing notice of termination to the management agent at least thirty (30) days before the expiration of the one (1) year.

## ARTICLE II

### ASSESSMENTS

A. The Association shall be assessed as the person or entity in possession of any tangible personal property of the Condominium owned or possessed in common by the Co-owners, and personal property taxes based thereon shall be treated as expenses of administration.

B. All costs incurred by the Association in satisfaction of any liability arising within, caused by, or connected with the Common Elements or the administration of the Condominium Project shall constitute expenditures affecting the administration of the Project, and all sums received as the proceeds of, or pursuant to, a policy of insurance securing the interest of the Co-owners against liabilities or losses arising within, caused by, or connected with the Common Elements or the administration of the Condominium Project shall constitute receipts affecting the administration of the Condominium Project.

C. Assessments shall be determined in accordance with the following provisions:

1. The Board of Directors of the Association shall establish an annual budget in advance for each fiscal year and such budget shall project all expenses for the forthcoming year which may be required for the proper operation, management and maintenance of the Condominium Project, including a reasonable allowance for contingencies and reserves. An adequate reserve fund for maintenance, repairs and replacement of those Common Elements that must be replaced on a periodic basis shall be established in the budget and must be funded by regular monthly payments as set forth in Section D below rather than by special assessments. At a minimum, the reserve fund shall be equal to ten percent (10%) of the Association's current annual budget on a non-cumulative basis. The minimum standard required by this section may prove to be inadequate for a particular Project. The Association of Co-owners shall carefully analyze their Condominium Project to determine if a greater amount should be set aside or if additional reserve funds should be established for other purposes. Upon adoption of an annual budget by the Board of Directors, copies of said budget shall be mailed or emailed to each Co-owner, although the delivery of a copy of the budget to each Co-owner shall not affect the liability of any Co-owner for any existing or future assessments. Should the Board of Directors at any time determine, in the sole discretion of the Board of Directors:
  - a. that the assessments levied are or may prove to be insufficient to pay the costs of operation and management of the Condominium;
  - b. to provide replacements of existing Common Elements;
  - c. to provide additions to any Common Element not exceeding \$2,500.00 annually; or

d. in the event of emergencies;

the Board of Directors shall have the authority to increase the general assessment or to levy such additional assessment or assessments as it shall deem to be necessary.

2. Special assessments, in addition to those required in Paragraph C(1) above may be made by the Board of Directors from time to time and approved by the Co-owners. Special assessments referred to in this paragraph shall not be levied without the prior approval of more than sixty percent (60%) of all Co-owners in value and in number.

D. All assessments levied against the Co-owners to cover expenses of administration shall be apportioned among and paid by the Co-owners in accordance with the Percentage of Value allocated to each Unit in Article V of the Master Deed without increase or decrease for the existence of any rights to the use of Limited Common Elements appurtenant to a Unit. Annual assessments as determined in accordance with Article II, Paragraph C(1) above, shall be payable by Co-owners in twelve (12) equal monthly installments, commencing with acquisition of legal or equitable title to a Unit. The payment of an assessment shall be in default if such assessment, or any part thereof, is not paid to the Association in full on or before the due date for such payment. Assessments in default shall bear interest at the rate of seven percent (7%) per annum until paid in full. Each Co-owner (whether one or more persons) shall be and remain personally liable for the payment of all assessments pertinent to his Unit which may be levied while such Co-owner is the owner thereof.

E. No Co-owner may exempt himself from liability for his contribution toward the expenses of administration by waiver of the use or enjoyment of any of the Common Elements or by the abandonment of his Unit.

F. Collection of Assessments. All remedies are discussed herein are cumulative and nothing herein shall limit the Association's right to use any legal means and remedy available against delinquent Owners.

1. *Suit at Law or Equity.* The Association may enforce collection of delinquent assessments by a suit at law for a money judgment or by foreclosure of the statutory lien that secures payment of assessments. Each Co-owner, and every other person who, from time to time, has any interest in the Project, shall be deemed to have granted to the Association the unqualified right to elect to foreclose such lien either by judicial action or by advertisement, and further, to have authorized and empowered the Association to sell or to cause to be sold the Unit with respect to which the assessment(s) is or are delinquent and to receive, hold and distribute the proceeds of such sale in accordance with the priorities established by applicable law. Notwithstanding anything to the contrary, neither a judicial foreclosure action nor a suit at law for a money judgment shall be commenced, nor shall any notice of foreclosure by advertisement be published until the expiration of ten (10) days after

mailing, by First Class Mail, postage prepaid, addressed to the delinquent Co-owner(s) at his or their last known address of a written notice that one or more installments of the annual assessment levied against the pertinent Unit is or are delinquent and that the Association may invoke any of its remedies hereunder if the delinquency is not cured within ten (10) days after the date of mailing. Such written notice shall be in recordable form, executed by an authorized representative of the Association and shall set forth the following: (1) the name of the Co-owner of record thereof, (2) the legal description of the Condominium Unit or Units to which the notice applies, (3) the amounts due the Association of Co-owners at the date of notice, exclusive of interest, costs, attorney fees and future assessments. The notice shall be recorded in the office of the Register of Deeds in the county in which the Condominium Project is located prior to the commencement of any foreclosure proceeding, but it need not have been recorded as of the date of mailing as aforesaid. If the delinquency is not cured within the ten (10) day period, the Association may take such remedial action as may be available to it hereunder or under Michigan law. A receiver may be appointed in an action for foreclosure of the assessment lien and may be empowered to take possession of the Condominium Unit, and to lease the Condominium Unit and to collect and apply the rental therefrom. The Co-owner of a Condominium Unit subject to foreclosure under this section, and any purchaser, grantee, successor or assignee of the Co-owner's interest in the Condominium Unit is liable for assessments by the Association chargeable to the Condominium Unit that become due before expiration of the period of redemption together with interest, advances made by the Association for taxes or other liens to protect its lien, costs and attorney fees incurred in their collection.

2. *Other Remedies.* In the event of default by any Co-owner in the payment of any installment of the annual assessment levied against his Unit, the Association shall have the right to declare all unpaid installments of the annual assessment for the pertinent fiscal year immediately due and payable. The Association may also discontinue the furnishing of any services to a Co-owner in default upon seven (7) days' written notice to such Co-owner of its intent to do so. A Co-owner in default shall not be entitled to vote at any meeting of the Association so long as such default continues. Further, a Co-owner in default may be barred from using any and all Common Elements until the default is cured.
3. *Costs.* The expenses incurred in collecting unpaid assessments, including interest, costs, actual attorney fees (not limited to statutory fees), and advances for taxes or other liens paid by the Association to protect its lien, shall be chargeable to the Co-owner in default and shall be secured by the lien on his Unit(s). The Board may also adopt an administrative fee that relates to the increased cost of the association in the collection of delinquent assessments.

G. Notwithstanding any other provisions of the Condominium Documents, the holder of any first mortgage covering any Unit in the Project which comes into possession of the Unit, pursuant to the remedies provided in the mortgage or by deed (or assignment) in lieu of foreclosure, or any purchaser at a foreclosure sale, shall take the property free of any claims for unpaid assessments

or charges against the mortgaged Unit which accrue prior to the time such holder comes into possession of the Unit (except for claims for a pro rata share of such assessments or charges resulting from a pro rata reallocation of such assessments or charges to all Units including the mortgaged Unit).

H. The Developer shall only be responsible for payment of the full Association maintenance assessment (but not any special assessments) for all Completed Units it owns and is currently renting; otherwise, for Completed Units it owns which it is not renting and for incomplete Units it owns, the Developer shall not be responsible for payment of any assessments. "Completed Unit" shall mean a Unit with respect to which a certificate of occupancy has been issued by the local public authority. An "Incomplete Unit" shall mean any Unit that is not a Completed Unit.

The Developer shall maintain, at its own expense, any Incomplete Units it owns and shall pay its portion of real estate taxes in the year of the establishment of the Condominium.

I. All property taxes and special assessments levied by any public taxing authority shall be assessed in accordance with the Act.

J. A construction lien otherwise arising under Act No. 179 of the Michigan Public Acts of 1891, as amended, shall be subject to Section 132 of the Act. Pursuant to Section 111 of the Act, the purchaser of any Condominium Unit may request a statement of the Association as to the outstanding amount of any unpaid assessments. Upon receipt of a written request to the Association accompanied by a copy of the right to acquire a Unit, the Association shall provide a written statement of such unpaid assessments as may exist or a statement that none exist, which statement shall be binding upon the Association for the period stated therein. Upon the payment of that sum within the period stated, the Association's lien for assessments as to such Unit shall be deemed satisfied; provided, however, that the failure of a purchaser to request such statement at least five (5) days prior to the closing of the purchase of such Unit, shall render any unpaid assessments and the lien securing same, fully enforceable against such purchaser and the Unit itself, to the extent provided by the Act. Under the Act, unpaid assessments constitute a lien upon the Unit and the proceeds of sale thereof prior to all claims except real property taxes and first mortgages of record.

K. Upon the sale or conveyance of a Condominium Unit, all unpaid assessments against the Condominium Unit shall be paid out of the sale price or by the purchaser in preference over any other assessments or charges of whatever nature except (a) amounts due the State of Michigan or any subdivision thereof for taxes or special assessments due and unpaid on the Unit; and (b) payments due under first mortgages having priority thereto. A purchaser of a Condominium Unit is entitled to written statement from the Association, setting forth the amount of unpaid assessments outstanding against the Unit, and the purchaser is not liable for unpaid assessments in excess of the amount set forth in such written statement, nor shall the Unit be subject to any lien for any amounts in excess of the amount set forth in the written statement. Any purchaser or grantee who fails to request a written statement from the Association as provided herein at least five (5) days before the sale, or arrange for the payment of any unpaid assessments against the Unit at the closing of the Unit purchase if such a statement was requested, shall be liable for any

unpaid assessments against the Unit together with interest, costs, and attorney's fees incurred in connection with the collection thereof.

L. Contributions to Working Capital Reserve by Purchasers of Units from Initial Co-owners. The Board of Directors of the Association shall have the right to require that the purchasers of a Unit that is being resold by the initial non-Developer Co-owners of the Unit or by any subsequent Co-owners contribute to the Association an amount up to or equal to two (2) months of the regular Association assessment upon closing on the sale of the Unit, with said contribution being deposited in the Association's reserve accounts. The imposition of this requirement upon the purchasers of resold Units shall not affect the non-refundable character of any previous contributions paid to the Association by the selling Co-owner. The Association Board of Directors shall provide written notice to the Co-owners of its election to require the contribution described in this Section and such written notice shall remain effective until negated by a subsequent written notice from the Board. The Association shall also have any and all remedies with respect to the unpaid contribution that are provided to the Association in these Bylaws for delinquent assessments.

### ARTICLE III

#### ARBITRATION

A. Disputes, claims or grievances arising out of or relating to the interpretation or the application of the Condominium Documents, or any disputes, claims or grievances arising among or between Co-owners and the Association shall, upon the election and written consent of the parties to any such disputes, claims or grievances and written notice to the Association, be submitted to arbitration and the parties thereto shall accept the arbitrator's decision as final and binding. The Commercial Arbitration Rules of the American Arbitration Association as amended and in effect from time to time hereafter shall be applicable to any such arbitration.

B. In the absence of an election and consent to arbitrate pursuant to Paragraph A of this Article III, no Co-owner or the Association shall be precluded from petitioning the courts to resolve any such disputes, claims or grievances.

C. Election by Co-owners or the Association to submit any such dispute, claim or grievance to arbitration shall preclude such parties from litigating such dispute, claim or grievance in the courts.

### ARTICLE IV

#### INSURANCE

A. The Association shall provide an insurance policy providing "special" and "all risk" coverage and liability insurance, and such other insurance as the Board of Directors deems advisable, pertinent to the ownership, use and maintenance of the Common Elements of the Condominium Project.

B. All such insurance shall be purchased by the Association for the benefit of the Association and the Co-owners and their mortgagees as their interests may appear and all premiums for insurance carried by the Association shall be an expense of administration.

C. Each Co-owner may obtain all necessary insurance coverage at his own expense upon his Unit. It shall be each Co-owner's responsibility to obtain insurance coverage for his personal property located within his Unit or elsewhere on the Condominium Project, for his personal liability for occurrences within his Unit or upon the Limited Common Elements appurtenant to his Unit, and the Association shall have absolutely no responsibility for obtaining such coverage.

D. All Common Elements of the Condominium Project shall be insured against fire and other perils covered by standard extended coverage endorsement in an amount equal to the maximum insurable replacement value, excluding foundation and excavation costs, as determined annually by the Board of Directors of the Association. Such coverage shall also include interior walls within any Unit and the pipes, wires, conduits and ducts contained therein, and shall further contain all fixtures, equipment and trim within a Unit which were furnished with the Unit as standard items in accordance with the plans and specifications thereof as are on file with the Association (or such replacements thereof as do not exceed the cost of such standard items). Any improvements made by a Co-owner within a Unit shall be covered by insurance obtained by and at the expense of said Co-owner; provided that, if the Association elects to include such improvements under its insurance coverage, any additional premium cost to the Association attributable thereto shall be assessed to and borne solely by said Co-owner and collected as a part of the assessments against said Co-owner under Article II hereof.

E. The proceeds of any insurance policies received by the Association as a result of any loss requiring repair or reconstruction shall be applied for such repair or reconstruction and in no event shall hazard insurance proceeds be used for any purpose other than for repair, replacement or reconstruction of the Project unless all of the institutional holders of first mortgages on Units in the Project have given their prior written approval.

F. Each Co-owner, by ownership of a Unit in the Condominium Project, shall be deemed to appoint the Association as his true and lawful attorney-in-fact to act in connection with all matters concerning the maintenance of fire and extended coverage, vandalism and malicious mischief, liability insurance and worker's compensation insurance, if applicable, pertinent to the Condominium Project, his Unit and the Common Elements appurtenant thereto with such insurer as may, from time to time, provide such insurance to the Condominium Project.

G. Neither the Association nor any of the Co-owners shall be liable to the other or to any insurance company (by way of waiver of subrogation) providing coverage for any loss or damage to any Common Element, improvement, Unit, building, structure or other tangible property, or any resulting loss of income, even though such loss or damage might have been occasioned by the negligence of the other party, its agents, guests, invitees or employees, provided and to the extent such loss or damage is covered by insurance.



## ARTICLE V

### RECONSTRUCTION OR REPAIR

A. If any part of the Condominium property shall be damaged, the determination of whether or not it shall be reconstructed or repaired shall be made in the following manner:

1. If the damaged property is a Common Element or a Unit, the property shall be rebuilt or repaired if any Unit in the Condominium is tenantable, unless it is determined that the Condominium shall be terminated and each institutional holder of a first mortgage lien on any Unit in the Condominium has given its prior written approval of such termination.
2. If the Condominium is so damaged that no Unit is tenantable, and if each institutional holder of a first mortgage lien on any Unit in the Condominium has given its prior written approval of the termination of the Condominium, the damaged property shall not be rebuilt and the Condominium shall be terminated, unless seventy-five percent (75%) or more of the Co-owners in value and in number agree to reconstruction by vote or in writing within ninety (90) days after the destruction.

B. Any such reconstruction or repair shall be substantially in accordance with the Master Deed and the plans and specifications for the Project.

C. If the damage is only to a part of a Unit, which is the responsibility of a Co-owner to maintain and repair, it shall be the responsibility of the Co-owner to repair such damage in accordance with Paragraph D below. In all other cases, the responsibility for construction and repair shall be that of the Association.

D. Each Co-owner shall be responsible for the reconstruction, repair and maintenance of the interior of his Unit, including, but not limited to, floor coverings, wall coverings, window shades, draperies, interior walls (but not any Common Elements therein), interior trim, furniture, light fixtures and all appliances whether free standing or built-in. In the event damage to interior walls within a Co-owner's Unit or to pipes, wires, conduits, ducts or other Common Elements thereof, or to any fixtures, equipment and trim which are standard items within a Unit is covered by insurance held by the Association, then the reconstruction or repair shall be the responsibility of the Association in accordance with Paragraph F below. If any other interior portion of a Unit is covered by insurance held by the Association for the benefit of the Co-owner, the Co-owner shall be entitled to receive the proceeds of insurance relative thereto and if there is a mortgagee endorsement, the proceeds shall be payable to the Co-owner and the mortgagees jointly. In the event of substantial damage to or destruction of any Unit or any part of the Common Elements, the Association shall promptly notify each institutional holder of a first mortgage lien on any of the Units of the Condominium.

E. No Co-owner shall make any structural repair or modification to his or her Unit without prior written consent of the Association. The Association shall not consent if such repair or modification may jeopardize or impair the structural soundness or safety, or both, of the Condominium Project.

F. The Association shall be responsible for the reconstruction, repair and maintenance of the Common Elements. Immediately after a casualty causing damage to property for which the Association has a responsibility for maintenance, repair and reconstruction, the Association shall obtain reliable and detailed estimates of the cost to replace the damaged property in a condition as good as that sufficient to defray the estimated costs of reconstruction or repair required to be performed by the Association, or if at any time during such reconstruction or repair, or upon completion of such reconstruction or repair, the funds for the payment of the costs thereof are insufficient, assessments shall be made against all Co-owners for the cost of reconstruction or repair of the damaged property in sufficient amounts to provide funds to pay the estimated or actual cost of repair.

G. The following provisions shall control upon any taking by eminent domain:

1. In the event of any taking of an entire Unit by eminent domain, the award for such taking shall be paid to the owner of such Unit and the mortgagee thereof, as their interests may appear. After acceptance of such award by the owner and his mortgagee, they shall be divested of all interest in the Condominium Project. In the event that any condemnation award shall become payable to any Co-owner whose Unit is not wholly taken by eminent domain, then such award shall be paid the condemning authority to the Co-owner and his mortgagee, as their interest may appear.
2. If there is any taking of any portion of the Condominium other than any Unit the condemnation proceeds relative to such taking shall be paid to the Co-owners and their mortgagees in proportion to their respective interests in the Common Elements and the affirmative vote of more than seventy-five percent (75%) of the Co-owners in number and in value shall determine whether to rebuild, repair or replace the portion so taken or to take such other action as they deem appropriate.
3. In the event the Condominium Project continues after taking by eminent domain, then the remaining portion of the Condominium Project shall be re-surveyed and the Master Deed amended accordingly, and, if any Unit shall have been taken, then Article V of the Master Deed shall also be amended to reflect such taking and to proportionately readjust the Percentages of Value of the remaining Co-owners, based upon the continuing value of the Condominium of one hundred percent (100%). Such amendment may be effected by an officer of the Association duly authorized by the Board of Directors without the necessity of execution or specific approval thereof by any Co-owner, but only with the prior written approval of all holders of first mortgage liens on individual Units in the Project.

4. The Association shall promptly notify each institutional holder of a first mortgage lien on any of the Units in the Condominium in the event that any Unit or portion thereof or the Common Elements or any portion thereof is made the subject matter of any condemnation or eminent domain proceeding.

H. Nothing contained in the Condominium Documents shall be construed to give a Condominium Unit owner or any other party priority over any rights of first mortgagees of Condominium Units pursuant to their mortgages and in the case of a distribution to Condominium Unit owners of insurance proceeds or condemnation awards for losses to or a taking of Condominium Units and/or Common Elements.

## ARTICLE VI

### RESTRICTIONS

A. No Unit in the Condominium shall be used for other than dry storage purposes and the Common Elements shall be used only for purposes consistent with the use of the individual Units. The Units shall not be used for commercial purposes unless approved in writing by the Board of Directors.

B. A Co-owner may lease his Unit for the same purposes set forth in Paragraph A of this Article VI and pursuant to the provisions of Article VII of these Bylaws; provided, however, that the lease term shall not be less than 30 days in duration.

C. Except as specifically provided for herein, no Co-owner shall make alterations in exterior appearance or make structural modifications to his Unit (including interior walls through or in which there exists easements for support or utilities) or make changes in any of the Common Elements without the express written approval of the Board of Directors including (but not by way of limitation) exterior painting or the erection of antennas, lights, aerials, awnings, doors (including screen doors), shutters or other exterior attachments or modifications. The Board of Directors may approve only such modifications as do not impair the soundness, safety, utility or appearance of the Condominium. As long as the removal of a wall dividing two (2) or more Units will not materially impact the soundness, safety, utility or appearance of the Project, if a Co-owner owns two (2) or more adjoining Units, the Co-owner may remove the interior wall dividing the Units it owns. The Co-owner removing any wall in accordance with this paragraph shall be liable for all costs and expenses related to such removal and installation and any cost and expense related to any damage to the Project as a whole related to the removal of such walls.

D. No immoral, improper, unlawful or offensive activity shall be carried on in any Unit or upon the Common Elements, limited or general, nor shall anything be done which may or becomes an annoyance or a nuisance to the Co-owners of the Condominium, nor shall any unreasonably noisy activity be carried on in any Unit or on the Common Elements. No Co-owner shall do or permit anything to be done or keep or permit to be kept in his Unit or on the Common Elements anything that will increase the rate of insurance on the Condominium without the written approval of the Association and each Co-owner shall pay to the Association the increased cost of insurance premiums resulting from any such activity or the maintenance of any such condition.

E. The Common Elements, limited or general, shall not be used for storage of supplies, materials, personal property or trash or refuse of any kind, except as provided in duly adopted rules and regulations of the Association.

F. Driveways, roads and parking areas shall not be obstructed in any way nor shall they be used for purposes other than for which they are reasonably and obviously intended.

G. No items may be stored outside a Unit.

H. No sign or other advertising device shall be displayed on any Unit or Common Element, except those of Developer, its affiliates, assigns or agents, while Developer or any of its affiliated organizations, own a Unit or fraction of a Unit within the Condominium Project. The Developer, its affiliates, assigns and agents are not restricted as to the form size shape, or content of any sign it displays within the Condominium Project. The Developer, its affiliates, assigns and agents may freely display signs within the Condominium Project, including without limitation its Common Elements without the approval or consent of the Board or any Co-owner. Signs used by a builder or lender to advertise the property during the construction or sales phase of the Condominium Project will be allowed only after Developer, its affiliates, assigns and agents have no interest in any Unit in the Condominium Project.

I. Reasonable regulations consistent with the Act, the Master Deed and these Bylaws may be made and amended from time to time by any Board of Directors of the Association, including the First Board of Directors (or its successors elected by the Developer) prior to the First Annual Meeting of the entire Association held as provided in Article I, Paragraph H, of these Bylaws. Copies of all such regulations and amendments thereto shall be furnished to all Co-owners and shall become effective thirty (30) days after mailing or delivery thereof to the designated voting representative of each Co-owner. Any such regulation or amendment may be revoked at any time by the affirmative vote of more than fifty percent (50%) of all Co-owners in number and in value except that the Co-owners may not revoke any regulation or amendment prior to said First Annual Meeting of the entire Association.

J. The Association or its duly authorized agents shall have access to each Unit and any Limited Common Elements appurtenant thereto from time to time, during reasonable working hours, upon notice to the Co-owner thereof, as may be necessary for the maintenance, repair or replacement of any of the Common Elements. The Association or its agents shall also have access to each Unit and any Limited Common Elements appurtenant thereto at all times without notice as may be necessary to make emergency repairs to prevent damage to the Common Elements or to another Unit. It shall be the responsibility of each Co-owner to provide the Association means of access to his Unit and any Limited Common Elements appurtenant thereto during all periods of absence and in the event of the failure of such Co-owner to provide means of access, the Association may gain access in such manner as may be reasonable under the circumstances and shall not be liable to such Co-owner for any necessary damage to his Unit and any Limited Common Elements appurtenant thereto caused thereby or for repair or replacement of any doors or windows damaged in gaining such access.

K. Each Co-owner shall maintain his Unit and any Limited Common Elements appurtenant thereto for which he has maintenance responsibility in a safe, clean and sanitary condition. The Co-owner shall be responsible for shoveling of all sidewalks and entryways to all Units. Each Co-owner shall also use due care to avoid damaging any of the Common Elements including, electrical conduits and systems. Each Co-owner shall be responsible for damages or costs to the Association resulting from negligent damage to or misuse of any of the Common Elements by him, or his guests, agents or invitees, unless such damages or costs are paid by insurance carried by the Association in which case there shall be no such responsibility (unless reimbursement to the Association is excluded by virtue of a deductible provision, in which case the responsible Co-owner shall bear the expense to the extent of the deductible amount). Any costs or damages to the Association may be assessed to and collected from the responsible Co-owner in the manner provided in Article II hereof.

## ARTICLE VII

### LEASING

A. Before the Transitional Control Date, during the development and sales period the rights of a Co-owner, including the Developer, to rent any number of Condominium Units shall be controlled by the provisions of the Condominium Documents as recorded by the Developer and shall not be changed without Developer approval. After the Transitional Control Date, the Association may amend the Condominium Documents as to the rental of Condominium Units or terms of occupancy. The amendment shall not affect the rights of any lessors or lessees under a written lease otherwise in compliance with this section and executed before the effective date of the amendment, or Condominium Units that are owned or leased by the Developer.

B. A Co-owner, including the Developer, desiring to rent or lease a Condominium Unit shall disclose that fact in writing to the Association at least ten (10) days before presenting a lease or otherwise agreeing to grant possession of a Condominium Unit to potential lessees or occupants and, at the same time, shall supply the Association with a copy of the exact lease for its review for its compliance with the Condominium Documents. The Co-owner or Developer shall also provide the Association with a copy of the executed lease. If no lease is to be used, then the Co-owner or Developer shall supply the Association with the name and address of the lessees or occupants, along with the rental amount and due dates of any rental or compensation payable to a Co-owner or Developer, the due dates of that rental and compensation and the term of the proposed arrangement.

C. Tenants or non-Co-owner occupants shall comply with all of the conditions of the Condominium Documents of the Condominium Project and all leases and rental agreements shall so state.

D. If the Association determines that the tenant or non-Co-owner occupant failed to comply with the conditions of the Condominium Documents, the Association shall take the following action:

1. The Association shall notify the Co-owner by certified mail, advising of the alleged violation by the tenant. The Co-owner shall have fifteen (15) days after receipt of the notice to investigate and correct the alleged breach by the tenant or advise the Association that a violation has not occurred.
2. If after fifteen (15) days the Association believes that the alleged breach is not cured or may be repeated, it may institute on its behalf or derivatively by the Co-owners on behalf of the Association, if it is under the control of the Developer, an action for both eviction against the tenant or non-Co-owner occupant and, simultaneously, for money damages against the Co-owner and tenant or non-Co-owner occupant for breach of the conditions of the Condominium Documents. The relief provided for in this section may be by summary proceeding. The Association may hold both the tenant and the Co-owner liable for any damages to the General Common Elements caused by the Co-owner or tenant in connection with the Condominium Unit or Condominium Project.

E. When a Co-owner is in arrearage to the Association for assessments, the Association may give written notice of the arrearage to a tenant occupying a Co-owner's Condominium Unit under a lease or rental agreement, and the tenant, after receiving the notice, shall deduct from rental payments due the Co-owner the arrearage and future assessments as they fall due and pay them to the Association. The deduction does not constitute a breach of the rental agreement or lease by the tenant. If the tenant, after being notified, fails or refuses to remit rent otherwise due the Co-owner to the Association, then the Association may do the following:

1. Issue a statutory notice to quit for non-payment of rent to the tenant and shall have the right to enforce that notice by summary proceeding.
2. Initiate proceedings pursuant to Paragraph D(2).

## ARTICLE VIII

### MORTGAGES

Any Co-owner who mortgages his Unit shall notify the Association of the name and address of the mortgagee, and the Association shall maintain such information in a book entitled "Mortgages of Units". The Association may, at the written request of a mortgagee of any such Unit, report any unpaid assessments due from the Co-owner of such Unit. The Association shall give to the holder of any first mortgage covering any Unit in the Project written notification of any default in the performance of the obligations of the Co-owner of such Unit that is not cured within sixty (60) days.

A. The Association shall notify each mortgagee appearing in said book of the name of each company insuring the Condominium against fire, perils covered by extended coverage and vandalism and malicious mischief and the amounts of such coverage.

B. Upon request submitted to the Association, any institutional holder of a first mortgage lien on any Unit on the Condominium shall be entitled to receive written notification of every meeting of the members of the Association and to designate a representative to attend such meeting.

C. The Association shall give timely notice to all mortgagees of: (1) any condemnation or casualty loss that affects either a material portion of the project or the Unit securing its mortgage; (2) any 60-day delinquency in the payment of assessments or charges owed by the owner of any Unit on which it holds the mortgage; (3) a lapse, cancellation or material modification of any insurance policy maintained by the Association; and (4) any proposed action that requires the consent of a specified percentage of mortgagees.

#### ARTICLE IX

#### AMENDMENTS

Amendments to these Bylaws shall be in accordance with Article X of the Master Deed.

#### ARTICLE X

#### COMPLIANCE

The Association of Co-owners and all present or future Co-owners, tenants, future tenants or any other persons acquiring an interest in or using the facilities of the Project in any manner are subject to and shall comply with the Act, as amended, and the mere acquisition, occupancy or rental of any Unit or an interest therein or the utilization of or entry upon the Condominium premises shall signify that the Condominium Documents are accepted and ratified. In the event the Condominium Documents conflict with the provisions of the Act, the Act shall govern.

#### ARTICLE XI

#### DEFINITIONS

All terms used herein shall have the same meaning as set forth in the Master Deed to which these Bylaws are attached as an Exhibit or as set forth in the Act.

#### ARTICLE XII

#### REMEDIES FOR DEFAULT

A. Any default by a Co-owner shall entitle the Association or another Co-owner or Co-owners to the following relief:

1. Failure to comply with any of the terms or provisions of the Condominium Documents or the Act shall be grounds for relief, which may include, but without limiting, an action to recover sums due for damages, injunctive relief, foreclosure

of lien or any combination thereof, and such relief may be sought by the Association or, if appropriate, by an aggrieved Co-owner or Co-owners.

2. In any proceeding arising because of an alleged default by an Co-owner or in any proceeding brought against the Association or its officer and/or directors to compel enforcement of the Condominium Documents, the Association, if successful, shall be entitled to recover the costs of the proceeding and such reasonable attorneys' fees (not limited to statutory fees), as may be determined by the Court, but in no event shall any Co-owner be entitled to recover such attorneys' fees.

3. The violation of any of the provisions of the Condominium Documents shall also give the Association or its duly authorized agents the right, in addition to the rights set forth above, to enter upon any Common Elements, Limited or General, or into any Unit, where reasonably necessary, and summarily remove and abate, at the expense of the Co-owner in violation, any structure, thing or condition existing or maintained contrary to the provisions of the Condominium Documents.

4. The violation of any of the provisions of the Condominium Documents by any Co-owner shall be grounds for assessment by the Association, acting through its duly constituted Board of Directors, of monetary fines for such violations. Fines may be assessed only upon notice to the offending Co-owners as prescribed in the Association Bylaws and an opportunity for such Co-owner to appear before the Board no less than seven (7) days from the date of the notice and offer evidence in defense of the alleged violation. All fines duly assessed may be collected in the same manner as provided in Article II of these Bylaws.

B. The failure of the Association or of any Co-owner to enforce any right, provision, covenant or condition which may be granted by the Condominium Documents shall not constitute a waiver of the right of the Association or of any such Co-owner to enforce such right, provisions, covenant or condition in the future.

C. All rights, remedies and privileges granted to the Association or any Co-owner or Co-owners pursuant to any terms, provisions, covenants or conditions of the aforesaid Condominium Documents shall be deemed to be cumulative and the exercise of any one or more shall not be deemed to constitute an election of remedies, nor shall it preclude any party thus exercising the same from exercising such other and additional rights, remedies or privileges as may be available to such party at law or in equity.

D. Recovery of Costs and Attorney's Fees. The Association shall be entitled to recover from the responsible Co-owner, lessee, tenant, non-Co-owner resident and/or guest, the pre-litigation costs and attorney fees, including those incurred in bankruptcy proceedings and/or probate proceedings, incurred in obtaining any of their compliance with the Condominium Documents and the Act. A Co-owner, if successful in suing another Co-owner, lessee, tenant, non-Co-owner resident and/or guest, shall be entitled to recover from the responsible Co-owner, lessee, tenant, non-Co-owner resident and/or guest the costs and attorney's fees incurred in obtaining any of their



compliance with the Condominium Documents and the Act. The Association shall have no responsibility to collect or enforce any judicial or administrative orders against or obtained by a Co-owner against another Co-owner, lessee, tenant, non-Co-owner resident and/or guest. In any proceeding arising because of an alleged default by a Co-owner, lessee, tenant, non-Co-owner resident and/or guest, the Association, if successful, shall be entitled to recover the costs of the proceeding, including all those incurred in any appellate, bankruptcy and/or probate proceedings, and such reasonable attorney fees (not limited to statutory fees) as may be determined by the Court, but in no event shall any Co-owner be entitled to recover such costs and/or attorney fees from the Association. The Association, if successful, also shall be entitled to recoup the costs and attorney's fees incurred in defending any claim, counterclaim or other matter asserted against the Association from the Co-owner asserting the claim, counterclaim or other matter, or whose lessee, tenant, non-Co-owner resident and/or guest asserted the claim, counterclaim or other matter, but in no event shall any Co-owner, lessee, tenant, non-Co-owner resident and/or guest be entitled to recover such costs and/or attorney's fees from the Association.

### ARTICLE XIII

#### SEVERABILITY

In the event that any of the terms, provisions or covenants of these Bylaws or the Condominium Documents are held to be partially or wholly invalid or unenforceable for any reason whatsoever, such holding shall not affect, alter, modify or impair in any manner whatsoever any of the other terms, provisions or covenants of such documents or the remaining portions of any terms, provisions or covenants held to be partially invalid or unenforceable.

### ARTICLE XIV

#### CONFLICTING PROVISIONS

In the event of a conflict between the provisions of the Act (or other laws of the State of Michigan) and any Condominium Document, the Act (or other laws of the State of Michigan) shall govern. In the event of any conflict between the provisions of any one or more Condominium Documents, the following order of priority shall prevail and the provisions of the Condominium Document having the highest priority shall govern:

1. The Master Deed, including the Condominium Subdivision Plan;
2. These Condominium Bylaws;
3. The Articles of Incorporation of the Association;
4. The Bylaws of the Association; and
5. The Rules and Regulations of the Association.

ARTICLE XV

CAPTIONS

The captions contained in these Condominium Bylaws are for convenient reference only, and do not add to or detract from nor in any way expand or limit the content of the Articles and Sections set forth herein.

ARTICLE XVI

COMPLIANCE WITH ORDINANCES

The Condominium is subject to the Township Zoning Ordinance which contains restrictions in addition to those found in the Master Deed and Bylaws and any applicable requirements of the State of Michigan.

Prepared by:  
David H. Rowe, Esq.  
*Atward, Fisher, Rice, Rowe & Graf, PLC*  
412 S. Union Street  
Traverse City, Michigan 49684  
(231) 346-5400

W:\Crystal Lake Storage Barns LLC\Crystal Lake Storage Barns\Condominium Bylaws 7-1-24.docx

BENZIE COUNTY CONDOMINIUM  
SUBDIVISION PLAN NO. 92  
EXHIBIT B TO MASTER DEED OF

CRYSTAL LAKE STORAGE BARNNS

VILLAGE OF BENZONIA  
BENZIE COUNTY, MICHIGAN

DEVELOPER:

CRYSTAL LAKE STORAGE BARNNS, LLC  
892 LODGE PINE LANE  
TRAVERSE CITY, MI 49684

PROPERTY DESCRIPTION:

Part of Lot 4, Block 28, Plat of Village of Benzonia, Section 34, Town 26 North, Range 15 West, Benzonia Township, Benzie County, Michigan; more fully described as follows:  
Commencing at the Southwest corner of said Lot 4; thence along the Northernly Right-Of-Way of South Street S 87°43'24" E a distance of 100.01' (RECORD S 88°06'28" E 100.00') to the Point Of Beginning; thence N 01°18'51" E a distance of 306.40' (RECORD N 00°04'51" E 306.21') to the Northernly line of said Lot 4; thence along said line S 87°52'10" E a distance of 200.11' (RECORD S 89°06'33" E 200.00'); thence continuing along said Northernly line S 87°52'05" E a distance of 135.36' (RECORD S 89°08'33" E 135.39'); thence S 01°23'23" W a distance of 306.17' (RECORD S 00°05'32" W 306.22') to said Northernly Right-Of-Way line of South Street; thence along said line N 87°54'24" W a distance of 335.07' (RECORD N 89°06'28" W 335.33') to the Point Of Beginning.  
Consisting of 2.36 acres.

Subject to a 33' wide easement for ingress and egress in part of Lot 4, Block 28, Plat of Village of Benzonia, Section 34, Town 26 North, Range 15 West, Benzonia Township, Benzie County, Michigan; the exterior of said easement is more fully described as follows:  
Commencing at the Southwest corner of said Lot 4; thence along the Northernly Right-Of-Way line of South Street S 87°43'24" E a distance of 100.01' (RECORD S 89°06'28" E 100.00'); thence continuing along said Right-Of-Way S 87°54'24" E a distance of 208.11' to the Point Of Beginning; thence N 28°43'00" E a distance of 46.71'; thence N 01°23'23" E a distance of 264.49' to the Northernly line of said Lot 4; thence along said line S 87°52'05" E a distance of 33.00'; thence S 01°23'23" W a distance of 272.08'; thence S 28°43'00" W a distance of 36.19' to said Northernly Right-Of-Way line of South Street; thence along said line N 87°54'24" W a distance of 36.91' to the Point Of Beginning.

Subject to and together with any easements, encroachments and/or restrictions if any.

ATTENTION: COUNTY REGISTER OF DEEDS  
THE CONDOMINIUM SUBDIVISION PLAN NUMBER MUST BE ASSIGNED IN  
CONSECUTIVE SEQUENCE. WHEN A NUMBER HAS BEEN ASSIGNED TO THIS  
PROJECT, IT MUST BE PROPERLY SHOWN ON THIS COVER SHEET AND THE  
SURVEYOR'S CERTIFICATE ON SHEET 2.

THIS CONDOMINIUM SUBDIVISION PLAN IS NOT REQUIRED TO  
CONTAIN DETAILED PROJECT DESIGN PLANS PREPARED BY THE  
APPROPRIATE LICENSED DESIGN PROFESSIONAL. SUCH PROJECT  
DESIGN PLANS ARE FILED AS PART OF THE CONSTRUCTION PERMIT  
APPLICATION, WITH THE ENFORCING AGENCY FOR THE STATE  
CONSTRUCTION CODE IN THE RELEVANT GOVERNMENTAL  
SUBDIVISION. THE ENFORCING AGENCY MAY BE A LOCAL BUILDING  
DEPARTMENT OR STATE DEPARTMENT OF LICENSING AND  
REGULATORY AFFAIRS.

SHEET INDEX

SHEET NO.	SHEET TITLE
1	COVER SHEET
2	SURVEY PLAN
3	SITE PLAN
4	UTILITY PLAN
5	FLOOR AND CROSS SECTION PLANS

PROFESSIONAL SURVEYOR

7-3-24

DATE

KELLY M. SIMMER  
PROFESSIONAL SURVEYOR NO. 4001053089  
SIMMER LAND SURVEYING  
404 W. MESICK AVE.  
MESICK, MICHIGAN 49668



CRYSTAL LAKE STORAGE BARNNS  
COVER SHEET



Kelly M. Simmer, P.S.  
404 W. Mesick Ave.  
Mesick, Michigan 49668  
kmsimmer@simmerlandsurveying.com

PROPOSED:  
JULY 3, 2024  
FILE: 495724C

SHEET 1

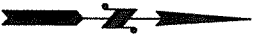

SCALE: 1" = 30'



LINE	BEARING	DISTANCE
L1	N 87°24'24" W	36.91
L2	N 28°43'00" E	46.71
L3	N 01°23'23" E	264.49
L4	S 87°52'05" E	33.00
L5	S 01°23'23" W	272.08
L6	S 28°43'00" W	38.19

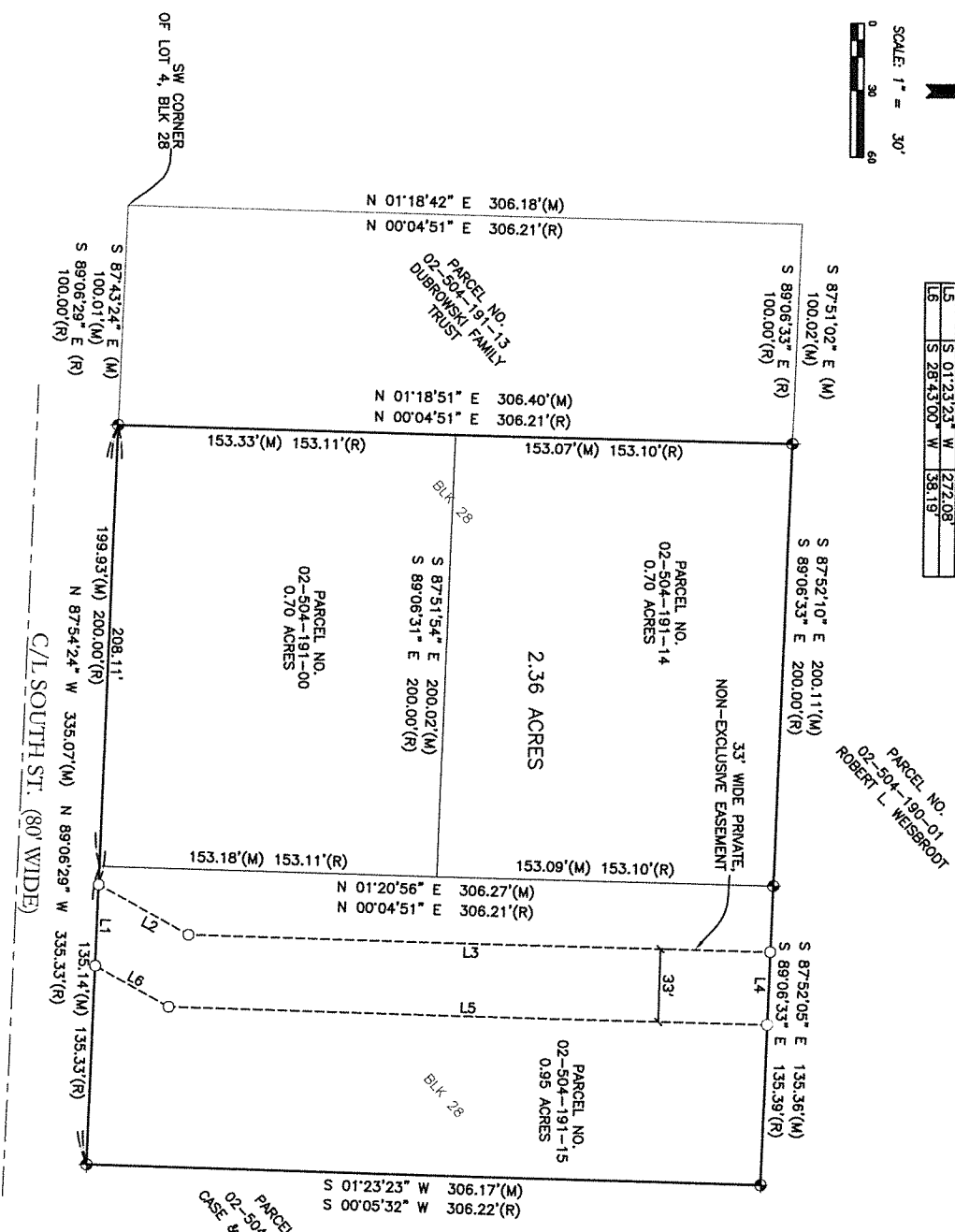

LOCATION MAP  
NO SCALE

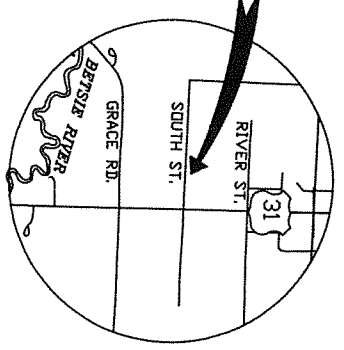

LEGEND:

- ⊕ = MAJOR BOUNDARY MONUMENT
- ⊕ X 3/8" CONC. MON. & CAP #53089
- ⊕ = FOUND MAJOR BOUNDARY MONUMENT
- = FOUND 1/2" ROD & CAP
- = UNIT BOUNDARY MONUMENT
- X 1/8" ROD & CAP #53089
- (R) = PREVIOUSLY RECORDED AS
- (M) = MEASURED

BEARINGS : NAD 83, SPC, MI CENTRAL.  
VERTICAL DATUM: NAVD 88

BEARINGS & DISTANCES ARE SHOWN AS MEASURED UNLESS OTHERWISE STATED. ERROR OF DISCLOSURE DOES NOT EXCEED 1:5000.



BENCH MARK: SET NAIL IN POWER POLE  
ELEV.: 696.22'  
N.: 4766933.88  
E.: 19233166.44

I, KELLY M. SIMMER, PROFESSIONAL LAND SURVEYOR OF THE STATE OF MICHIGAN, HEREBY CERTIFY:

THAT THE SUBDIVISION PLAN KNOWN AS CRYSTAL LAKE STORAGE BARN, BENZIE COUNTY CONDOMINIUM SUBDIVISION PLAN NO. 92, AS SHOWN ON THE ACCOMPANYING DRAWINGS, REPRESENTS A SURVEY ON THE GROUND MADE UNDER MY DIRECTION, THAT THERE ARE NO EXISTING ENCROACHMENTS UPON THE LANDS AND PROPERTY HERIN DESCRIBED;

THAT THE REQUIRED MONUMENTS AND IRON MARKERS WILL BE PLACED IN THE GROUND AS REQUIRED BY RULES PROULGATED UNDER SECTION 142 OF ACT NO. 59 OF THE PUBLIC ACTS OF 1978 NO LATER THAN ONE YEAR FROM THE DATE OF THIS CERTIFICATION;

THAT THE ACCURACY OF THIS SURVEY IS WITHIN THE LIMITS REQUIRED BY THE RULES PROULGATED UNDER SECTION 142 OF ACT NO. 59 OF THE PUBLIC ACTS OF 1978;

THAT THE BEARINGS, AS SHOWN, ARE NOTED ON THE SURVEY PLAN AS REQUIRED BY THE RULES PROULGATED UNDER SECTION 142 OF ACT NO. 59 OF THE PUBLIC ACTS OF 1978.

DATE 7-3-24

*[Signature]*

KELLY M. SIMMER  
PROFESSIONAL SURVEYOR NO. 4001053089  
SIMMER LAND SURVEYING  
404 W. MESICK AVE.  
MESICK, MICHIGAN 49688



CRYSTAL LAKE STORAGE BARN  
SURVEY PLAN

**SIMMER**  
LAND SURVEYING  
PROPOSED:  
JULY 3, 2024  
FILE: 495724C

Kelly M. Simmer, P.S.  
Professional Land Surveyor  
404 W. Mesick Ave., Mesick, MI 49688  
C# 02311-259-2914





SCALE: 1" = 30'

LEGEND:  
ELECTRIC  
STORM

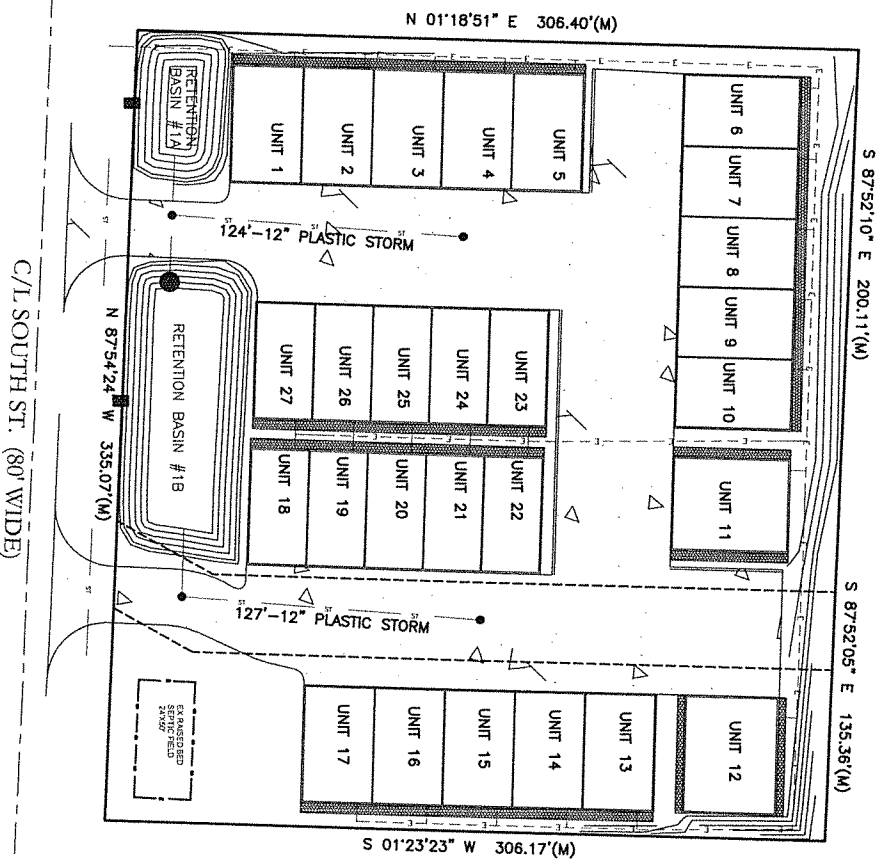

NOTE: ALL IMPROVEMENTS SHOWN NEED NOT BE BUILT.  
ENTIRE PROJECT IS CONVERTIBLE AND CONTRACTIBLE.  
EXISTING UTILITIES ARE SHOWN FROM FIELD MEASUREMENTS AND SUPPLIED DOCUMENTATION.

7-3-24

DATE

KELLY M. SIMMER  
PROFESSIONAL SURVEYOR NO. 4001053089  
SIMMER LAND SURVEYING  
404 W. MESSICK AVE.  
MESSICK, MICHIGAN 49668



CRYSTAL LAKE STORAGE BARNS  
UTILITY PLAN

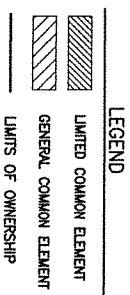
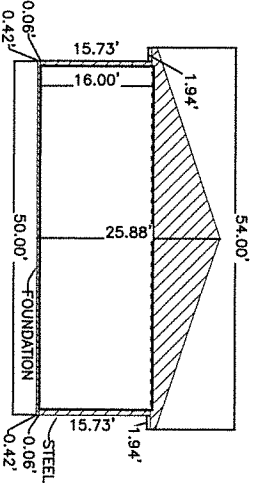
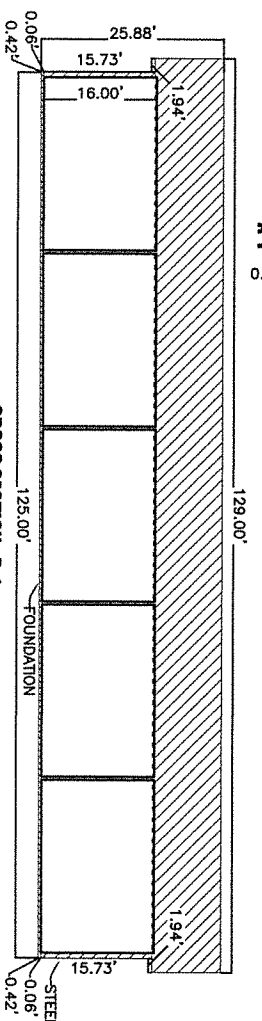
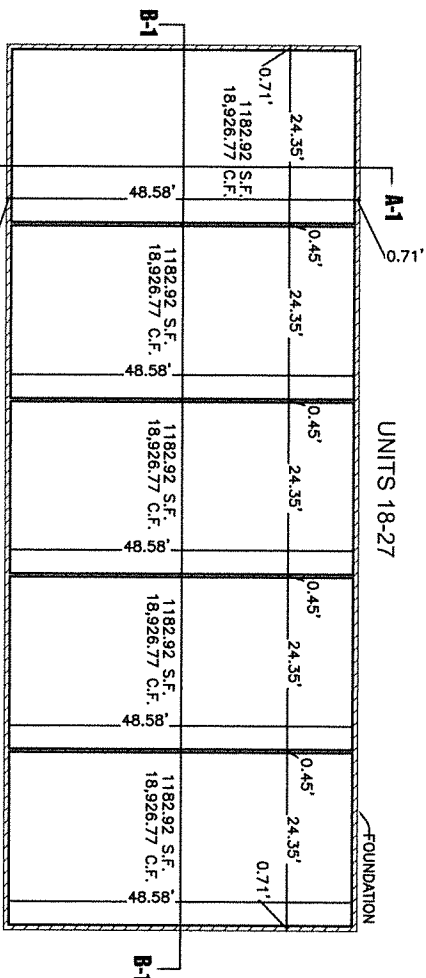
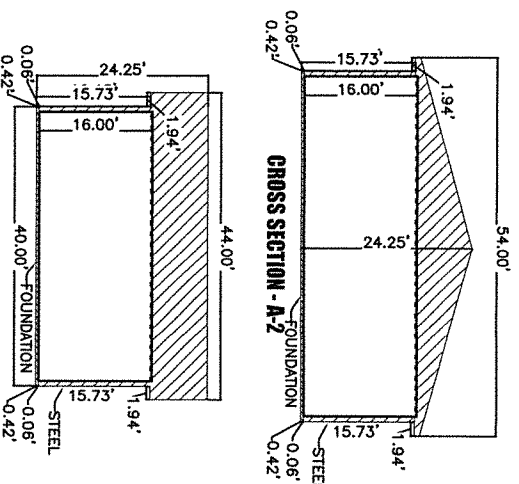
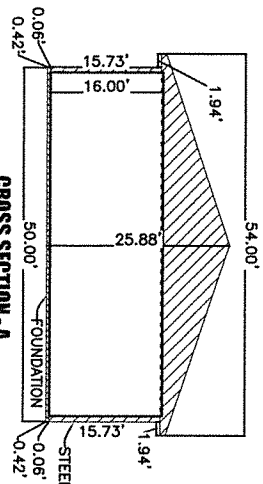
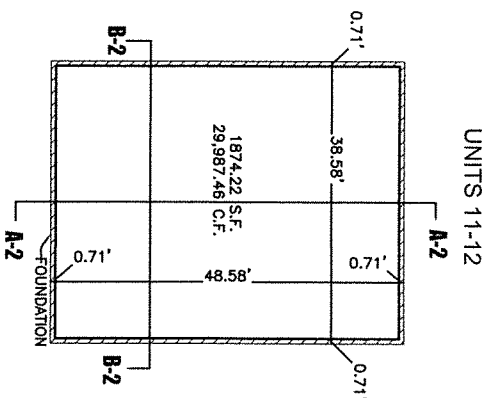
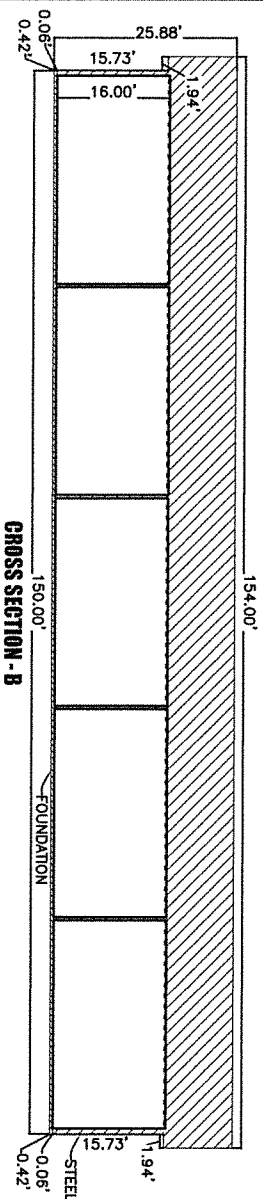
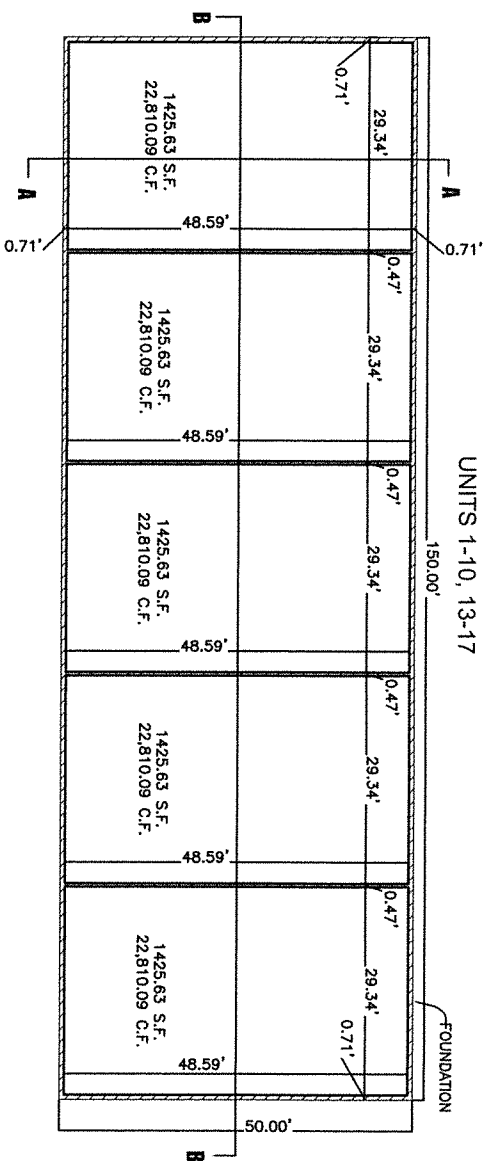

NOTE: ALL IMPROVEMENTS SHOWN  
NEED NOT BE BUILT.  
ENTIRE PROJECT IS CONVERTIBLE AND  
CONTRACTABLE.

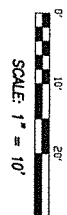

DATE 7-3-24

*[Signature]*



KELLY M. SIMMER  
PROFESSIONAL SURVEYOR NO. 4001053089  
SIMMER LAND SURVEYING  
404 W. MESICK AVE.  
MESICK, MICHIGAN 49668

CRYSTAL LAKE STORAGE BARNS  
FLOOR AND CROSS SECTION PLANS

**SIMMER**  
LAND SURVEYING  
Kelly M. Simmer, P.S.  
Professional Land Surveyor  
404 W. Mesick Ave. • Mesick, MI 49668  
Cell: (231) 419-4914

PROPOSED:  
JULY 3, 2024  
FILE: 495724C







Form Revision Date 07/2016

## ARTICLES OF INCORPORATION

For use by DOMESTIC NONPROFIT CORPORATION

Pursuant to the provisions of Act 162, Public Acts of 1982, the undersigned corporation executes the following Articles:

### ARTICLE I

The name of the corporation is:

CRYSTAL LAKE STORAGE BARNs CONDOMINIUM ASSOCIATION

### ARTICLE II

The purpose or purposes for which the corporation is formed are:

A. To manage, control and administer the common elements of CRYSTAL LAKE STORAGE BARNs, a storage Condominium (hereinafter called "Condominium"), located in the Township of Benzonia, County of Benzie and State of Michigan;

B. To levy and collect assessments against and from the members of the Corporation and to use the proceeds thereof for the purposes of the Corporation;

C. To carry insurance and to collect and allocate the proceeds thereof;

D. To rebuild improvements after casualty;

E. To contract for and employ persons, firms or corporations to assist in management, operation, maintenance and administration of said Corporation;

F. To make and enforce reasonable regulations concerning the use and enjoyment of said Condominium;

G. To own, maintain and improve, and to buy, sell, convey, assign, mortgage or lease (as landlord or tenant) any real and personal property, including, but not limited to, any unit in the Condominium, for any purpose of providing benefit to the members of the Corporation and in furtherance of any of the purposes of the Corporation;

H. To borrow money and issue evidences of indebtedness in furtherance of any or all of the objects of its business; to secure by mortgage, pledge or other lien;

I. To enforce the provisions of the Master Deed and Bylaws of the Condominium and of these Articles of Incorporation and such Bylaws and Rules and Regulations of this Corporation as may hereinafter be adopted;

J. To do anything required of or permitted to it as administrator of said Condominium by the Condominium Master Deed or Bylaws or by Act No. 59 of Public Act of 1978, as amended; and

K. In general, to enter into any kind of activity, to make and perform any contract and to exercise all powers necessary, incidental or convenient to the administration, management, maintenance, repair, replacement and operation of said Condominium and to the accomplishment of any of the purposes thereof.

### ARTICLE III

The Corporation is formed upon  basis.

If formed on a stock basis, the total number of shares the corporation has authority to issue is

If formed on a nonstock basis, the description and value of its real property assets are (if none, insert "none"):

None

The description and value of its personal property assets are (if none, insert "none"):

None

The corporation is to be financed under the following general plan:

Assessment of members.

The Corporation is formed on a  basis.

#### ARTICLE IV

The street address of the registered office of the corporation and the name of the resident agent at the registered office (P.O. Boxes are not acceptable):

1. Agent Name: DAVID H. ROWE
2. Street Address: 412 S. UNION STREET  
Apt/Suite/Other:  
City: TRAVERSE CITY  
State: MI Zip Code: 49684
3. Registered Office Mailing Address:  
P.O. Box or Street Address: 412 S. UNION STREET  
Apt/Suite/Other:  
City: TRAVERSE CITY  
State: MI Zip Code: 49684

#### ARTICLE V

The name(s) and address(es) of the incorporator(s) is (are) as follows:

Name	Residence or Business Address
DAVID SPERRY	892 LODGE PINE LANE, TRAVERSE CITY, MI 49684 USA

Use the space below for additional Articles or for continuation of previous Articles. Please identify any Article being continued or added.

#### ARTICLE VI.

THE NAMES OF THE FIRST BOARD OF DIRECTORS ARE AS FOLLOWS:

DAVID SPERRY  
STEVE TRAFFORD  
AUTUMN TRAFFORD

THE BUSINESS ADDRESS OF THE FIRST BOARD OF DIRECTORS IS 892 LODGE PINE LANE, TRAVERSE CITY, MI 49684.

#### ARTICLE VII.

THE TERM OF CORPORATE EXISTENCE IS PERPETUAL.

#### ARTICLE VIII.

THE QUALIFICATION OF MEMBERS, THE MANNER OF THEIR ADMISSION TO THE CORPORATION, THE TERMINATION OF MEMBERSHIP AND VOTING BY SUCH MEMBERS SHALL BE AS FOLLOWS:

A. EACH CO OWNER (INCLUDING THE DEVELOPER) OF A UNIT (LOT) IN THE CONDOMINIUM SHALL BE A MEMBER OF THE CORPORATION, AND NO OTHER PERSON OR ENTITY SHALL BE ENTITLED TO MEMBERSHIP; EXCEPT THAT THE SUBSCRIBERS HERETO SHALL BE MEMBERS OF THE CORPORATION UNTIL SUCH TIME AS THEIR MEMBERSHIP SHALL TERMINATE, AS HEREINAFTER PROVIDED.

B. MEMBERSHIP IN THE CORPORATION (EXCEPT WITH RESPECT TO ANY NON CO OWNER INCORPORATORS, WHO SHALL CEASE TO BE MEMBERS UPON THE QUALIFICATION FOR MEMBERSHIP OF ANY CO OWNER) SHALL BE ESTABLISHED BY ACQUISITION OF FEE SIMPLE TITLE TO A UNIT (LOT) IN THE CONDOMINIUM AND BY RECORDING WITH THE REGISTER OF DEEDS IN THE COUNTY WHERE THE CONDOMINIUM IS LOCATED, A DEED OR OTHER INSTRUMENT ESTABLISHING A CHANGE OF RECORD TITLE TO SUCH UNIT (LOT) AND THE FURNISHING OF EVIDENCE OF SAME SATISFACTORY TO THE CORPORATION (EXCEPT THAT THE DEVELOPER OF THE CONDOMINIUM SHALL BECOME A MEMBER IMMEDIATELY UPON ESTABLISHMENT OF THE CONDOMINIUM) THE NEW CO OWNER THEREBY BECOMING A MEMBER OF THE CORPORATION, AND THE MEMBERSHIP OF THE PRIOR CO OWNER THEREBY BEING TERMINATED.

C. THE SHARE OF A MEMBER IN THE FUNDS AND ASSETS OF THE CORPORATION CANNOT BE ASSIGNED, PLEDGED, ENCUMBERED OR

TRANSFERRED IN ANY MANNER EXCEPT AS AN APPURTENANCE TO HIS UNIT (LOT) IN THE CONDOMINIUM.

D. VOTING BY MEMBERS SHALL BE IN ACCORDANCE WITH THE PROVISIONS OF THE BYLAWS OF THIS CORPORATION.

ARTICLE IX.

A. A VOLUNTEER OFFICER OR DIRECTOR OF THE CORPORATION SHALL NOT BE PERSONALLY LIABLE TO THE CORPORATION OR ITS MEMBERS FOR MONETARY DAMAGES FOR A BREACH OF FIDUCIARY DUTY AS A VOLUNTEER OFFICER OR DIRECTOR, EXCEPT FOR LIABILITY:

1. THE AMOUNT OF A FINANCIAL BENEFIT RECEIVED BY A VOLUNTEER OFFICER OR DIRECTOR TO WHICH HE OR SHE IS NOT ENTITLED;
2. INTENTIONAL INFLICTION OF HARM ON THE CORPORATION OR ITS MEMBERS;
  3. A VIOLATION OF MCL 450.2551;
  4. AN INTENTIONAL CRIMINAL ACT;
  5. A LIABILITY IMPOSED UNDER MCL 450.2497(A).

B. THE CORPORATION ASSUMES LIABILITY FOR ALL ACTS OR OMISSIONS OF VOLUNTEER DIRECTOR, VOLUNTEER OFFICER OR OTHER VOLUNTEER OCCURRING ON OR AFTER THE DATE OF THESE ARTICLES OF INCORPORATION IF ALL OF THE FOLLOWING ARE MET:

1. THE VOLUNTEER WAS ACTING OR REASONABLY BELIEVED HE OR SHE WAS ACTING WITHIN THE SCOPE OF HIS OR HER AUTHORITY.
2. THE VOLUNTEER WAS ACTING IN GOOD FAITH.
3. THE VOLUNTEER'S CONDUCT DID NOT AMOUNT TO GROSS NEGLIGENCE OR WILLFUL AND WANTON MISCONDUCT.
4. THE VOLUNTEER'S CONDUCT WAS NOT AN INTENTIONAL TORT.

5. THE VOLUNTEER'S CONDUCT WAS NOT A TORT ARISING OUT OF THE OWNERSHIP, MAINTENANCE OR USE OF A MOTOR VEHICLE FOR WHICH TORT LIABILITY MAY BE IMPOSED AS PROVIDED IN SECTION 3135 OF THE INSURANCE CODE OF 1956, ACT. NO. 218 OF THE PUBLIC ACTS OF 1956, BEING SECTION 500.3135 OF THE MICHIGAN COMPILED LAWS.

C. IF THE MICHIGAN NONPROFIT CORPORATION ACT IS AMENDED TO AUTHORIZE CORPORATE ACTION FURTHER ELIMINATING OR LIMITING THE PERSONAL LIABILITY OF OFFICERS OR DIRECTORS, THEN THE LIABILITY OF THE OFFICERS AND DIRECTORS OF THE CORPORATION SHALL BE ELIMINATED OR LIMITED TO THE FULLEST EXTENT PERMITTED BY THE ACT, AS SO AMENDED.

D. THE CORPORATION ASSUMES ALL LIABILITY TO ANY PERSON OTHER THAN THE CORPORATION OR ITS MEMBERS FOR ALL ACTS OR OMISSIONS OF A VOLUNTEER DIRECTOR INCURRED IN THE GOOD FAITH PERFORMANCE OF THE VOLUNTEER DIRECTOR'S DUTIES.

ANY REPEAL, MODIFICATION OR ADOPTION OF ANY PROVISION IN THESE ARTICLES OF INCORPORATION INCONSISTENT WITH THIS ARTICLE SHALL NOT ADVERSELY AFFECT ANY RIGHT OR PROTECTION OF THE OFFICERS AND DIRECTORS OF THE CORPORATION EXISTING AT THE TIME OF SUCH REPEAL, MODIFICATION OR ADOPTION.

Signed this 12th Day of August, 2024 by the incorporator(s).

Signature	Title	Title if "Other" was selected
David Sperry	Incorporator	

By selecting ACCEPT, I hereby acknowledge that this electronic document is being signed in accordance with the Act. I further certify that to the best of my knowledge the information provided is true, accurate, and in compliance with the Act.

 Decline       Accept

**MICHIGAN DEPARTMENT OF LICENSING AND REGULATORY AFFAIRS**

**FILING ENDORSEMENT**

***This is to Certify that the*** ARTICLES OF INCORPORATION

***for***

CRYSTAL LAKE STORAGE BARNs CONDOMINIUM ASSOCIATION

***ID Number:*** 803258136

***received by electronic transmission on*** August 12, 2024 ***, is hereby endorsed.***

***Filed on*** August 13, 2024 ***, by the Administrator.***

***The document is effective on the date filed, unless a subsequent effective date within 90 days after received date is stated in the document.***



***In testimony whereof, I have hereunto set my hand and affixed the Seal of the Department, in the City of Lansing, this 13th day of August, 2024.***

*Linda Clegg*

***Linda Clegg, Director***

***Corporations, Securities & Commercial Licensing Bureau***



## ASSOCIATION BYLAWS

### **CRYSTAL LAKE STORAGE BARNS CONDOMINIUM ASSOCIATION**

#### ARTICLE I.

##### ADOPTION OF CONDOMINIUM BYLAWS

The Bylaws of CRYSTAL LAKE STORAGE BARNS, a storage Condominium (hereinafter known as the "Condominium Bylaws"), as attached to the Master Deed and recorded in Document No. 2024-02301, Benzie County Records, are hereby incorporated by reference and adopted in their entirety as a part of the Bylaws of this Association.

#### ARTICLE II.

##### MEETINGS

- A. Meetings of the Association shall be held at the principal office of the Association or at such other suitable place convenient to the Co-owners as may be designated by the Board of Directors in accordance with Roberts' Rules of Order or some other generally recognized manual of parliamentary procedure, when not otherwise in conflict with the Articles of Incorporation, the Bylaws of the Condominium, the Condominium Master Deed or the laws of the State of Michigan.
- B. The First Annual Meeting of the Members of the Association shall be held in accordance with Article I, Paragraph H, of the Condominium Bylaws. The date, time and place of the First Annual Meeting shall be set by the Board of Directors and at least ten (10) days' written notice thereof shall be given to each Co-owner. Thereafter, Annual Meetings of members of the Association shall be held each succeeding year at such time and place as shall be determined by the Board of Directors. At such meetings there shall be elected, by ballot of the Co-owners, a Board of Directors in accordance with the requirements of Article III of these Bylaws. The Co-owners may also transact at such meetings such other business of the Corporation as may properly come before them.
- C. It shall be the duty of the president to call a special meeting of the Co-owners as directed by resolution of the Board of Directors or upon a petition signed by one-third (1/3) of the Co-owners presented to the secretary of the Association. Notice of any special meetings shall state the time and place of such meeting and the purposes thereof. No business shall be transacted at a special meeting except as stated in the notice.
- D. It shall be the duty of the secretary (or other Association officer in the secretary's absence) to serve a notice of each Annual or special meeting, stating the purpose thereof as well as the time and place where it is to be held, upon each Co-owner of record, at least ten (10) days but not more than sixty (60) days prior to such meeting. The electronic mailing, mailing, postage prepaid, of a notice to the representative of each Co-owner at the address found in

the notice required to be filed with the Association by Article I, Paragraph C(5) of the Condominium Bylaws shall be deemed notice served. Any member may, by written waiver of notice signed by such member, waive such notice and such waiver, when filed in the records of the Association, shall be deemed due notice.

- E. If any meeting of Co-owners cannot be held because a quorum is not in attendance, the owners who are present may adjourn the meeting for a time not less than forty-eight (48) hours from the time the original meeting was called.

### ARTICLE III.

#### BOARD OF DIRECTORS

- A. The affairs of the Corporation shall be governed by a Board of a minimum of three (3) directors, all of whom must be members of the Corporation, except for the first Board of Directors designated in the Articles of Incorporation of the Association. Directors shall serve without compensation.
- B. The first Board of Directors designated in the Articles of Incorporation shall manage the affairs of the Corporation until a successor Board of Directors is elected at the first meeting of members of the Corporation convened at the time required by Article II, Paragraph B, of these Bylaws. The term of office (except for the Board of Directors elected prior to the First Annual Meeting of members) of each director shall be one (1) year. Each director shall hold office until his successor has been elected and held a meeting.
- C. The Board of Directors shall have the following powers and duties:
  - 1. To manage and administer the affairs of and maintain the Condominium Project and any common elements thereof.
  - 2. To collect assessments from the members of the Association and to use the proceeds thereof for the purposes of the Association.
  - 3. To carry insurance and collect and allocate the proceeds thereof.
  - 4. To rebuild improvements after casualty.
  - 5. To contract for and employ persons, firms, corporations or other agents to assist in the management, operation, maintenance and administration of the Condominium Project.
  - 6. To acquire, maintain and improve, and to buy, operate, manage, sell, convey, assign, mortgage or lease any real or personal property (including any unit in the Condominium and easements, rights-of-way and licenses (on behalf of the Association and in furtherance of any of the purposes of the Association)).

7. To borrow money and issue evidences of indebtedness in furtherance of any and all of the purposes of the business of the Association, and to secure the same by mortgage, pledge or other lien on property owned by the Association; provided, however, that any such action shall also be approved by an affirmative vote of more than seventy-five percent (75%) of all the members of the Association, both in number and in value.
  8. To make rules and regulations in accordance with the Condominium Bylaws.
  9. To establish such committees as it deems necessary, convenient, or desirable and to appoint persons thereto for the purpose of implementing the administration of the Condominium and to delegate to such committees any functions or responsibilities which are not by law or the Condominium documents required to be performed by the Board.
  10. To make rules and regulations and/or enter into agreements with institutional lenders, the purpose of which is to obtain mortgage financing for the unit Co-owners.
  11. To enforce the provisions of the Condominium documents.
- D. Vacancies in the Board of Directors, including the first Board of Directors named in the Articles of Incorporation caused by any reason other than the removal of a director by a vote of the members of the Association, shall be filled by the vote of the majority of the remaining directors, even though they may constitute even less than a quorum. In the event that there are no remaining directors, the Association shall fill vacancies. Each person so elected shall be a director until a successor is elected at the next Annual Meeting of the Association. Prior to the First Annual Meeting of members, the Developer may remove and replace any and/or all of the directors from time to time in its sole discretion.
- E. At any regular or special meeting of the Association duly called, any one or more of the directors may be removed with or without cause by a majority of the Co-owners and a successor may then and there be elected to fill the vacancy thus created. Any director whose removal has been proposed by the Co-owners shall be given an opportunity to be heard at the meeting.
- F. The first meeting of the newly elected Board of Directors shall be held within ten (10) days of election at such place as shall be fixed by the directors at the meeting at which meeting such directors were elected and no notice shall be necessary to the newly elected directors in order legally to constitute such a meeting, providing a majority of the whole Board shall be present.
- G. Regular meetings of the Board of Directors may be held at such times and places as shall be determined from time to time by a majority of the directors, but at least two such meetings shall be held during each fiscal year. Notice of regular meetings of the Board of Directors shall be given to each director, personally, by electronic mail, mail, telephone or facsimile, at least ten (10) days prior to the date set for such meeting.



- H. Special meetings of the Board of Directors may be called by the president on three (3) days' notice to each director, given personally, by electronic mail, mail, telephone or facsimile, which notice shall state the time, place and purpose of the meeting. Special meetings of the Board of Directors shall be called by the president or secretary in like manner and on like notice on the written request of one director.
- I. Before or at any meeting of the Board of Directors any director may, in writing, waive notice of such a meeting and such waiver shall be deemed equivalent to the giving of such notice. Attendance by a director at any meeting of the Board shall be deemed a waiver of notice by him of the time and place thereof. If all the directors are present at any meeting of the Board, no notice shall be required and any business may be transacted at such meeting.
- J. At all meetings of the Board of Directors, a majority of the directors shall constitute a quorum for the transaction of business, and the acts of the majority of the directors present at a meeting at which a quorum is present shall be the acts of the Board of Directors. If, at any meeting of the Board of Directors, there be less than a quorum present, the majority of those present may adjourn the meeting from time to time. At any such adjourned meeting, any such business which might have been transacted at the meeting as originally called, may be transacted without further notice. The joinder of a director in the action of a meeting by signing and concurring in the minutes thereof shall constitute the presence of such director for the purposes of determining a quorum.
- K. The Board of Directors may require that all officers and employees of the Association handling and responsible for Association funds shall furnish adequate fidelity bonds. The premiums on such bonds shall be expenses of administration.

#### ARTICLE IV.

##### OFFICERS

- A. The principal officers of the Association shall be a president, who shall be a member of the Board of Directors, a vice-president, secretary and a treasurer. Directors may appoint an assistant treasurer and an assistant secretary and such other officers as, in their judgment, may be necessary. Any two offices, except that of president and vice-president, may be held by one person.
- B. The officers of the Association shall be elected annually by the Board of Directors at the organizational meeting of each new Board and shall hold office at the pleasure of the Board.
- C. Upon affirmative vote of the majority of the members of the Board of Directors, any officer may be removed either with or without cause, and his successor elected at any regular meeting of the Board of Directors or at any special meeting of the Board of Directors called for such purpose.

- D. The president shall be the chief executive officer of the Association. He shall preside at all meetings of the Association. He shall have all of the general powers and duties which are usually vested in the office of the president of an association, including, but not limited to, the power to appoint committees from among the members of the Association from time to time as he may, in his discretion, deem appropriate to assist in the conduct of the affairs of the Association.
- E. The vice-president shall take the place of the president and perform his duties whenever the president shall be absent and unable to act. If neither the president nor the vice-president is able to act, the Board of Directors shall appoint some other member of the Board to do so on an interim basis. The vice-president shall also perform such other duties as shall, from time to time, be imposed upon him by the Board of Directors.
- F. The secretary shall keep the minutes of all the meetings of the Board of Directors and the minutes of all the meetings of the members of the Association; he shall have charge of the books and papers as the Board of Directors may direct; and he shall, in general, perform all duties incident to the office of the secretary.
- G. The treasurer shall have responsibilities for the Association's funds and securities and shall be responsible for keeping full and accurate account of all receipts and disbursements in books belonging to the Association. He shall be responsible for the deposit of all monies and other valuable effects in the name and to the credit of the Association, and in such depositories, as made, from time to time, be designated by the Board of Directors.
- H. The officers shall have other duties, powers and responsibilities as shall, from time to time, be authorized by the Board of Directors.

## ARTICLE V.

### FINANCE

- A. The finances of the Corporation shall be handled in accordance with the Condominium Bylaws.
- B. The fiscal year of the Corporation shall be an annual period commencing on such date as may be initially determined by the directors. The commencement date of the fiscal year shall be subject to change by the directors for accounting reasons or other good cause.
- C. The funds of the Corporation shall be deposited in such bank as may be designated by the Board of Directors and shall be withdrawn only upon the check or order of such officers, employees or agents as are designated by resolution of the Board of Directors from time to time.

## ARTICLE VI.

### INDEMNIFICATION OF OFFICERS AND DIRECTORS

Every director and every officer of the Corporation shall be indemnified by the Corporation against all expenses and liabilities, including counsel fees, reasonably incurred by or imposed upon him in connection with any proceeding to which he may be a party or in which he may become involved, by reason of his being or having been a director or officer of the Corporation, whether or not he is a director or officer at the time such expenses are incurred, except in such cases wherein the director or officer is adjudged guilty of willful misfeasance or malfeasance in the performance of his duties; provided that, in the event of any claim for reimbursement or indemnification hereunder, based upon a settlement by the director or officer seeking such reimbursement or indemnification, the indemnification herein shall apply only if the Board of Directors (with the director seeking reimbursement abstained) proves such settlement and reimbursement as being in the best interest of the Corporation. The foregoing right of indemnification shall be in addition to and not exclusive of all other rights to which such director or officer may be entitled. At least ten (10) days prior to payment of any indemnification of which it has approved, the Board of Directors shall notify all Co-owners thereof.

## ARTICLE VII.

### AMENDMENT

- A. These Bylaws (but not the Condominium Bylaws) may be amended by the Association at a duly constituted meeting for such purpose, by affirmative vote of a simple majority of the Co-owners present in person, by proxy or by written or electronic vote, either by e-mail or online survey, as such vote is defined in Article I, Paragraph C(9) of the Condominium Bylaws.
- B. Amendment to these Bylaws may be proposed by the Board of Directors of the Association acting upon the vote of the majority of the directors or by one-third (1/3) or more in number of the members of the Association, whether meeting is members or by instrument in writing signed by them.
- C. Upon any such amendment being proposed, a meeting for consideration of the same shall be duly called in accordance with the provisions of Article II of these Bylaws.
- D. Any amendment to these Bylaws shall become effective upon adoption of the same in accordance with Paragraph A of this Article, without approval by the State of Michigan and without recording same in the Office of the Register of Deeds.
- E. A copy of each amendment to these Bylaws shall be furnished to every member of the Association after adoption.

ARTICLE VIII.

COMPLIANCE

These Bylaws are set forth to comply with the requirements of Act 162 of the Public Acts of Michigan of 1982, as amended, and Act 59 of the Public Acts of Michigan of 1978, as amended, with the duly recorded Master Deed of the Condominium and Exhibits "A" and "B" thereto. In the case any of these Bylaws conflict with the provisions of said statutes or with the provisions of said Master Deed or the exhibits thereto, provisions of the statute and said Master Deed shall control.

W:\Crystal Lake Barndominiums LLC\Crystal Lake Barndominium\Association Bylaws.docx



**CONDOMINIUM ESCROW AGREEMENT  
CRYSTAL LAKE STORAGE BARNS**

This **ESCROW AGREEMENT** is made by and between Crystal Lake Storage Barns, LLC, a Michigan limited liability company (the "Developer"), of 892 Lodge Pine Lane, Traverse City, MI 49684, and ATA National Title Group of 13919 S West Bay Shore Drive, Suite 105, Traverse City, Michigan 49684 (the "Escrow Agent");

**WITNESSETH:**

WHEREAS, Developer has established a storage Condominium known as CRYSTAL LAKE STORAGE BARNS under and in accordance with the Michigan Condominium Act (Act No. 59, Public Acts of 1978, as amended, hereinafter called the "Condominium Act"); and

WHEREAS, Developer plans to sell units in CRYSTAL LAKE STORAGE BARNS to such persons ("Subscribers") who shall execute and enter into Preliminary Reservation Agreements or Purchase Agreements (collectively referred to as "Purchase Agreement"); and

WHEREAS, all deposits received from Subscribers executing Purchase Agreements are required to be deposited in escrow with a bank, savings and loan association or title insurance company, licensed or authorized to do business in Michigan under and pursuant to the terms and conditions specified by Section 103b of the Condominium Act; and

WHEREAS, the parties desire to enter into this Agreement for the purpose of satisfying the escrow requirement of the Condominium Act; and

NOW, THEREFORE, the parties hereto hereby agree as follows:

1. **Deposit of Funds and Other Documents; Investment of Funds.** Developer shall promptly deposit with Escrow Agent all funds received as deposits from Subscribers executing a Purchase Agreement, together with a fully executed copy of each Agreement and, if then available, a signed copy of the receipt of each Subscriber required by Section 84a(3) of the Condominium Act acknowledging receipt of the documents required to be delivered by Section 84a(1) of the Act. If not delivered with the initial deposit of funds, the receipt required by Section 84a(3) shall be promptly delivered by Developer upon receipt of the same. Upon receipt of such funds, Escrow Agent shall place the same in an insured deposit account or certificate of deposit at such bank or other financial institution as Escrow Agent shall determine to be appropriate in the sole and exclusive exercise of its discretion to the end that such funds will be secured as to principal, insured against loss and readily liquid so that they may be released and disbursed to the Subscriber or Developer as otherwise provided by this Agreement.
2. **Interest Earned Upon Escrowed Funds.** Escrow Agent shall be under no obligation to earn interest upon the escrowed sums held pursuant hereto. In the event that interest upon such sums is earned, however, all such interest shall be separately accounted for by Escrow

Agent and shall be held in escrow and released as and when principal deposits are released hereunder; provided, however, that all interest earned on deposits refunded to a Purchaser upon the occasion of his withdrawal from a Purchase Agreement shall be paid to Developer.

3. **Release of Funds.** Escrow Agent shall hold all funds deposited with it, and all interest earned and accrued thereon, in escrow until the occurrence of one of the conditions set forth below, at which time Escrow Agent shall deliver the principal amount of such escrowed funds and interest accrued to date to the party indicated.
  - a. **Voluntary Withdrawal by Subscriber.** If the Subscriber shall withdraw from the Purchase Agreement prior to the time that the Purchase Agreement becomes binding as specified in Paragraph 2 of the Purchase Agreement, then within three (3) business days from the date of receipt of notice of such withdrawal from Developer, Escrow Agent shall deliver to the Subscriber the principal amount of the sum deposited pursuant to the Purchase Agreement and shall deliver to Developer all interest earned thereon.
  - b. **Default Prior to Purchase Agreement Becoming Binding.** If the Subscriber shall default in performing any obligation of the Purchase Agreement requiring Subscriber's performance prior to the time that the Purchase Agreement becomes binding as set forth in Paragraph 2 of the Purchase Agreement, and Developer elects to terminate the Purchase Agreement and so notifies Escrow Agent, then Escrow Agent shall promptly deliver to the Subscriber the principal amount of the sum deposited pursuant to the Purchase Agreement and shall deliver all interest earned thereon to Developer.
  - c. **Voluntary Withdrawal by Developer.** If Developer decides not to establish CRYSTAL LAKE STORAGE BARNS as a Condominium Project and so notifies Escrow Agent, then Escrow Agent shall deliver all funds deposited pursuant to the Purchase Agreement, together with all interest earned thereon, to the Subscriber.
  - d. **Inability to Obtain Financing.** If the Purchase Agreement is contingent upon the Subscriber obtaining a mortgage or other financing and permits the Subscriber to voluntarily withdraw in the event such financing is not obtained subsequent to the Purchase Agreement becoming binding, and the Subscriber is unable to obtain such financing and duly withdraws as a result thereof, then promptly following receipt of notice from Developer of such withdrawal, Escrow Agent shall deliver to the Subscriber the principal amount of the sum deposited pursuant to the Purchase Agreement and shall deliver to Developer all interest earned thereon unless otherwise specifically provided by the Purchase Agreement, in which case Escrow Agent shall disburse such funds as therein provided.
  - e. **Default After Purchase Agreement Becomes Binding.** If, after the Purchase Agreement becomes a binding agreement, either the Subscriber or the Developer shall default in performing their respective obligations therein set forth, and the non-defaulting party provides notice of such default as required by the Purchase

Agreement and provides a copy of such notice to Escrow Agent, then following the passage of such grace period, if any, as may be provided by the Purchase Agreement, Escrow Agent shall deliver all funds deposited pursuant to the Purchase Agreement, together with all interest earned thereon, to the non-defaulting party promptly following receipt of a written demand for the same, provided, however, that if prior to the release of such funds Escrow Agent receives a written objection to the notice of default or a written claim of interest in the funds from the alleged defaulting party, then Escrow Agent shall hold or dispose of the funds as provided in Paragraph 6 herein.

- f. **Upon Conveyance of Title to Purchaser.** Upon conveyance of title to a unit covered by a Purchase Agreement from the Developer to a Subscriber (or upon execution of a Land Contract between the Developer and the Subscriber in fulfillment of a Purchase Agreement) Escrow Agent shall release to Developer all sums held in escrow pursuant to such Agreement provided Escrow Agent has confirmed:
- (i) That all common elements or facilities intended for common use, wherever located and which under the terms of the Condominium documents "Must Be Built" are substantially complete; or
  - (ii) That, if the elements or facilities referred to in Subparagraph 3(f)(i) above are not substantially complete, sufficient funds to finance substantial completion of such elements or facilities are being retained in escrow or that other adequate security has been arranged as provided in Paragraph (4) below.

For purposes of improvements of the type described in Subparagraph 3(f)(i) above, said improvements shall be substantially complete when certificates of substantial completion have been issued therefore by the Developer and by a licensed professional architect or engineer, as described in Paragraph 6.

- g. **Release of Funds for Completion of Incomplete Improvements.** Upon furnishing Escrow Agent a certificate from a licensed professional architect or engineer evidencing substantial completion in accordance with the pertinent plans and specifications of a structure, improvement, facility or identifiable portion thereof for which funds or other security have been deposited in escrow, Escrow Agent shall release to Developer the amount of such funds or other security specified by the issuer of the certificate as being attributable to such substantially completed item(s); provided, however, that if the amounts remaining in escrow after any such partial release would be insufficient in the opinion of the issuer of such certificate to finance substantial completion of any remaining incomplete items for which funds or other security have been deposited in escrow, only the amount in escrow in excess of such estimated cost to substantially complete shall be released by Escrow Agent to Developer.



4. **Substitute Security.** Notwithstanding anything in this Agreement to the contrary, Developer may withdraw all of or part of the escrowed funds prior to the occurrence of any of the events set forth in Paragraph 3 above, provided that Developer shall deliver to Escrow Agent security having, in the judgment of the Escrow Agent, a value equal to the amount of the funds withdrawn, which security may include, without limitation, any irrevocable letter of credit, lending commitment, indemnification agreement or other resource of value which in the judgment of Escrow Agent is sufficient to assure repayment of the funds withdrawn.
5. **Proof of Occurrences.** Escrow Agent may require reasonable proof of any event, action or condition stated herein before releasing any funds held by it pursuant to any Purchase Agreement either to a Subscriber thereunder or to the Developer.
6. **Conflicting Claims.** If Escrow Agent receives conflicting instructions or claims to the funds, securities or documents held in escrow, then it may take any one or more of the following actions;
  - a. It may release all or any portion of the funds to the party which it reasonably determines in good faith to be entitled to receive such funds under other provisions of this Agreement;
  - b. It may hold all or any portion of the funds, securities and documents affected by the conflicting instructions or claims in escrow and take no further action until otherwise directed, either by mutual written instructions from all interested parties or final Order of a Court of competent jurisdiction; or
  - c. It may initiate an interpleader action in any Circuit Court in the State of Michigan naming all interested parties as parties and depositing all or any portion of the funds, securities and documents affected by the adverse claims with the Clerk of such Court in full acquittance of its responsibilities under this Agreement.
7. **Status and Liability of Escrow Agent.** Upon delivering or applying all funds deposited with it hereunder in accordance with this Agreement, and after performing the obligations and services required by law and in all Purchase Agreements, Escrow Agent shall be released from any further liability under this Agreement and the Purchase Agreements, it being expressly understood that liability is limited by the terms and the provisions set forth in this Agreement and the Purchase Agreements. By acceptance of this Agreement, Escrow Agent acknowledges that it is acting in the capacity of a depository and that it is not responsible or liable for the sufficiency, correctness, genuineness or validity of the instruments submitted to it by Developer, the marketability of title to any unit sold under any Purchase Agreement, or the nature, extent or quality of construction of any facility or improvement. Escrow Agent shall not be responsible for the failure of any bank used as a depository for funds received pursuant to this Agreement.
8. **Notices.** All notices required or permitted to be given pursuant to this Agreement and all notices of change of address shall be sufficient if personally delivered or sent by certified mail, postage prepaid and return receipt requested, addressed to the recipient at the address

shown above such party's signature on this Agreement or the pertinent Purchase Agreement. For purposes of calculating time periods under the provisions of this Agreement, all notices shall be deemed effective upon mailing or personal delivery, whichever is applicable.

9. **Construction.** This Agreement shall be subject to and construed, in all respects, in accordance with the laws of the State of Michigan. The words and phrases herein used shall have such meanings, if any, as are ascribed to them by the Condominium Act unless the context in which they are used clearly indicates to the contrary. In the event any term, covenant or condition of this Agreement or the application thereof to any person or circumstances shall to any extent be invalid or unenforceable, the remainder of this Agreement or the application of such term, covenant or condition to persons or circumstances other than those as to which it is held invalid or unenforceable, shall not be affected thereby, and each term, covenant or condition of this Agreement, so long as practicable, shall be valid and enforceable to the full extent permitted by law.
10. **Effective Date.** This Agreement shall become effective as of the date on which the last signature needed below has been obtained.
11. **Counterparts.** This Agreement may be executed in two or more counterparts, each of which shall be deemed an original but all of which together shall constitute one and the same instrument.

**IN WITNESS WHEREOF**, the undersigned parties have executed this Escrow Agreement as of the date last set forth below.

**DEVELOPER:**

Crystal Lake Storage Barns, LLC, a  
Michigan limited liability company

Dated: 6/20/2024, 2024

  
By: David Sperry  
Its: Member

**ESCROW AGENT:**

ATA National Title Group

Dated: 6/20/24, 2024

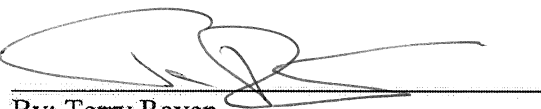
  
By: Terry Raven  
Its: Area Manager



**CONDOMINIUM PURCHASE AGREEMENT**

CRYSTAL LAKE STORAGE BARNS

Condominium Unit No. \_\_\_\_\_ (“Unit”)

WHEREAS, CRYSTAL LAKE STORAGE BARNS, LLC, a Michigan limited liability company (hereinafter "Developer"), is developing **CRYSTAL LAKE STORAGE BARNS**, a storage Condominium Project located in the Township of Benzonia, Benzie County, Michigan, and

WHEREAS, \_\_\_\_\_, (hereinafter "Purchaser") wishes to reserve the right to purchase a unit in the Project and to participate in the Association of Co-owners formed for the operation and regulation of the common elements of the Project.

**IT IS AGREED AS FOLLOWS:**

Purchaser, in consideration of the mutual promises of other Purchasers and other good and valuable consideration, hereby reserves the right to participate in the proposed Project by purchasing the above referred Condominium unit, together with an undivided interest in the common elements of the Project for the price of \$ \_\_\_\_\_ (the "Purchase Price").

Purchaser agrees that he will pay the Purchase Price as follows:

(a) \$ \_\_\_\_\_ upon execution of this Agreement (to be held in escrow with ATA National Title Group of 13919 S West Bay Shore Dr., Suite 105, Traverse City, MI 49684 under an Escrow Agreement dated June 20, 2024, the terms of which are incorporated herein and made a part hereof), provided further, all sums deposited shall be so held in escrow and shall be returned to the Purchaser within three (3) business days after withdrawal from this Agreement as provided herein,

(b) \$ \_\_\_\_\_ upon receipt of the Purchaser’s Information Booklet containing the Condominium documents (to be held in escrow under the same terms as Subparagraph (a) above),

(c) \$ \_\_\_\_\_ upon commencement of construction of Crystal Lake Storage Barns (to be held in escrow under the same terms as Subparagraph (a) above),

(d) To pay the remaining portion of the Purchase Price as follows:

(1) In cash at closing;

(2) To pay \$ \_\_\_\_\_ in cash and to finance the balance under a conventional mortgage.

If Purchaser elects to finance the Purchase Price under a conventional mortgage, he shall make good faith application at his sole cost for a mortgage commitment within ten (10) days after this Agreement becomes a binding purchase agreement pursuant to Paragraph 2 below.

Closing on the reserved unit shall occur thirty (30) days after a Certificate of Occupancy is issued.

Purchaser agrees that, in addition to the Purchase Price, he will be liable after closing for his proportionate share of the Association Assessment for maintenance, repair, replacement and other expenses of Administration as outlined in the Condominium Bylaws.

### 1. **PLAN AND PURPOSE**

Crystal Lake Storage Barns Condominium Association has been, or will be, established as a Michigan non-profit corporation for the purpose of operating and maintaining the common elements of the Condominium. Each Co-owner shall be a member of the Association and will be subject to the Bylaws and regulations thereof. Purchaser hereby subscribes to and agrees to abide by the terms, provisions, declarations, covenants and restrictions contained in the Master Deed, Condominium Bylaws and Condominium Subdivision Plans of the Project and the Articles of Incorporation, Bylaws and Regulations, if any, of the Association, the contents of which documents will be as Developer, in its discretion, deems appropriate.

### 2. **EFFECT OF AGREEMENT**

This Agreement shall become a binding purchase agreement upon Developer and Purchaser upon the expiration of nine (9) days after receipt by Purchaser of the Condominium documents. However, if Purchaser shall waive the nine (9) day period in writing, then this Agreement shall become immediately binding upon the execution of such waiver.

### 3. **CONVEYANCE OF TITLE**

In consideration of this Agreement, the Developer agrees to convey to Purchaser good and marketable title to said unit subject to easements and restrictions of record, all pertinent governmental regulations and subject to the instruments mentioned in Paragraph 1 above. Purchaser agrees to consummate the purchase of said unit from Developer within nine (9) days after Developer has notified Purchaser in writing that it is prepared to tender title and possession to him. It is understood that Purchaser will, at the time title is conveyed to him, pay all mortgage costs and such other closing costs as are customarily paid by the purchasers of comparable real estate in this jurisdiction and taxes, assessments and insurance will be adjusted to the date of closing.

County taxes, including township and school, shall be prorated on a calendar year basis, as if paid in arrears, so that Seller will be charged with the portion thereof from the prior January 1

to the date of closing, and Purchaser with the balance of the year. City taxes shall be prorated on a due date basis as if paid in advance so that Seller will be charged with the portion thereof from the prior July 1 to the date of closing, and Purchaser with the portion from the date of closing to the next June 30.

In addition to the Developer's credit for tax proration at the time of closing and in the event that the real property tax bills relative to the Condominium property have not yet been split into separate tax bills for each unit by the local tax assessor, Developer may require Purchaser to pay into an escrow account to be maintained by the Association an amount equal to Purchaser's estimated percentage of value share of real estate taxes with respect to the Condominium Project which will next fall due.

Within a reasonable time after closing, Developer, at its expense, will furnish Purchaser with an owner's title insurance policy issued in a face amount equal to the purchase price of the unit. A commitment therefore will be furnished to Purchaser by Developer at or prior to closing.

An amount equal to two (2) months' estimated maintenance assessment shall be paid by Purchaser to Developer on behalf of the Association at the time of closing as a non-refundable working capital deposit.

#### **4. CANCELLATION RIGHTS OF PURCHASER**

Unless the Purchaser waives the right of withdrawal, the Purchaser may withdraw from this Agreement without cause and without penalty if the withdrawal is made before conveyance of the unit and within nine (9) business days after receipt of the Condominium documents and the amounts theretofore paid by him under this Agreement will be refunded to him in full satisfaction and termination of any rights and liabilities of Purchaser and Developer of any sort hereunder and shall wholly cease and terminate.

#### **5. CANCELLATION RIGHTS OF DEVELOPER**

If Developer determines not to establish the Purchaser's unit in the Condominium Project, then Developer shall so notify Purchaser in writing. In such event, Developer reserves the right to return all sums received for reservation of the right to purchase said unit to Purchaser or his successors, and thereupon, all rights of Purchaser shall cease and terminate without further liability on the part of Developer.

The Developer may, at its option, release the obligations of Purchaser under this Agreement in the event Purchaser shall secure another Purchaser who is satisfactory to the Developer. This Agreement is not otherwise assignable.

## 6. **SECURITY FOR COMPLETION**

After expiration of the withdrawal period provided in Paragraph 5, Developer shall be required to retain sufficient funds in escrow or to provide sufficient security to assure completion of all improvements labeled "Must Be Built" in the Condominium Subdivision Plan.

## 7. **ARBITRATION**

At the exclusive option of the Purchaser, any claim which might be the subject of a civil action against the Developer which involves an amount less than Two Thousand Five Hundred and no/100 Dollars (\$2,500.00), and arises out of or relates to this purchase agreement or the unit or Project to which this agreement relates, shall be settled by binding arbitration conducted by the American Arbitration Association. Judgment upon the award rendered by arbitration may be entered in a circuit court of appropriate jurisdiction.

## 8. **DEFAULT**

If the Purchaser shall default in any of the payments or obligations called for in this Agreement and such default shall continue for ten (10) days after written notice sent by the Developer to the Purchaser, then, forthwith at the option of the Developer all rights of Purchaser under this Agreement shall terminate. If Purchaser's rights are terminated subsequent to this Agreement becoming a binding purchase agreement pursuant to Paragraph 2 hereof, any amount paid toward the Purchase Price shall be retained by the Developer as liquidated damages; provided, however, that such liquidated damages shall in no event exceed ten percent (10%) of the Purchase Price specified on page one hereof. If Purchaser's rights terminate prior to the time this Agreement becomes a binding purchase agreement pursuant to Paragraph 2 hereof, all sums paid by Purchaser shall be refunded to him and neither party hereto shall be obligated further.

## 9. **ORAL REPRESENTATION NOT TO BE RELIED UPON**

This Agreement will supersede any and all understandings and agreements and constitutes the entire agreement between the parties and no oral representations or statements shall be considered a part hereof.

## 10. **NOTICES**

All written notices required or permitted hereunder and all notices of change of address shall be deemed sufficient if personally delivered or sent by ordinary First Class Mail or by registered or certified mail, postage prepaid, and return receipt requested, addressed to the recipient party at the address shown below such party's signature to this Agreement. For purposes of calculating time periods under the provisions of this Agreement, notice shall be deemed effective upon mailing or personal delivery, whichever is applicable.

11. **USAGE OF TERMS**

The pronouns and relative words herein used shall be construed respectively to include the masculine, feminine and neuter genders and the singular and plural numbers unless the context indicates a contrary intention.

12. **THE CONDOMINIUM BUYERS' HANDBOOK**

Purchaser hereby acknowledges receipt prior to execution of this Agreement of a copy of the Condominium Buyers' Handbook published by the Michigan Department of Licensing and Regulatory Affairs.

This Agreement is executed by the parties on the \_\_\_\_\_ day of \_\_\_\_\_, 20\_\_\_. Purchaser hereby acknowledges receipt of a copy of this Agreement and the Escrow Agreement referred to above.

The covenants herein shall bind the heirs, personal representatives, administrators, executors, assigns and successors of the respective parties.

**THE PARTIES AGREE THAT THIS AGREEMENT IS SUBJECT TO AND INCLUDES THE GENERAL PROVISIONS CONTAINED HEREIN WHICH PURCHASER ACKNOWLEDGES THAT HE HAS READ.**

\_\_\_\_\_  
Purchaser

\_\_\_\_\_  
Purchaser

Address:

\_\_\_\_\_

\_\_\_\_\_

Email Address: \_\_\_\_\_



**DEVELOPER:**  
CRYSTAL LAKE STORAGE BARNS, LLC, a  
Michigan limited liability company

---

By: David Sperry  
Its: Member

Purchaser's Telephone No.: \_\_\_\_\_

Developer's Telephone No.: \_\_\_\_\_

W:\Crystal Lake Barndominiums LLC\Crystal Lake Barndominium\Purchase Agreement.docx

**EXHIBIT "A"**

**(Part of Purchase Agreement)**

Condominium Unit No. \_\_\_\_\_

Address: \_\_\_\_\_

\_\_\_\_\_

Purchaser: \_\_\_\_\_

The following is a list of additional items, changes and/or extra features to be added to the foregoing Condominium unit. Purchaser will pay the total price shown below for such items within ten (10) days after Purchase Agreement becomes a binding Purchase Agreement in accordance with the General Provisions and the liquidated damage provision set forth in the Purchase Agreement shall be applicable thereto in the event of Purchaser's default.

a.	_____	\$ _____
b.	_____	\$ _____
c.	_____	\$ _____
d.	_____	\$ _____
e.	_____	\$ _____
f.	_____	\$ _____
g.	_____	\$ _____
h.	_____	\$ _____
i.	_____	\$ _____
j.	_____	\$ _____
k.	_____	\$ _____
l.	_____	\$ _____

TOTAL: \$ \_\_\_\_\_

Dated: \_\_\_\_\_

\_\_\_\_\_ Purchaser

\_\_\_\_\_ Purchaser



**WAIVER**

The undersigned, for good cause acknowledged by the undersigned, hereby waives the nine (9) day waiting period from receipt of the Condominium documents as provided by the Condominium Act prior to closing of the purchase of Unit No. \_\_\_\_\_, **CRYSTAL LAKE STORAGE BARNS**. The undersigned represents and warrants that he/she is familiar with this Project, and has knowingly and intentionally and of his/her own volition waived the nine (9) day waiting period as provided by the Condominium Act.

\_\_\_\_\_  
\_\_\_\_\_  
\_\_\_\_\_

Date: \_\_\_\_\_

Unit No.: \_\_\_\_\_





# **THE CONDOMINIUM BUYER'S HANDBOOK**

The Condominium Buyer's Handbook is created by the Michigan Department of Licensing and Regulatory Affairs as required by the Condominium Act (PA 59 of 1978, as amended).  
This edition includes Public Act 170 of 2015 amendments.

## **PREFACE**

**The Department of Licensing & Regulatory Affairs has NO authority to enforce or regulate any provisions of the Act or the bylaws of condominium developments.**

The Condominium Buyer's Handbook is a guide for people who are interested in buying a condominium. For your protection, you should read this booklet before you sign a purchase agreement. This handbook contains a summary of portions of the Condominium Act. Although the information is directed primarily toward residential condominium buyers, the Act also covers business, manufactured housing, campground and marina condominium developments. The last section of the handbook describes the legal remedies that are available to you based on the Condominium Act.

Although the Department of Licensing and Regulatory Affairs is the designated administrator in the Act, the Legislature repealed the Department's regulatory and enforcement responsibilities in 1983.

Additional information may be found on our website at: [www.michigan.gov/condo](http://www.michigan.gov/condo)

**NOTE:** A person or association of co-owners adversely affected by a violation of, failure to comply with, the Condominium Act, administrative rules, or any provision of your bylaws or master deed may take action in a court of competent jurisdiction.

## **CONDOMINIUM OWNERSHIP**

Condominium unit co-owners have exclusive ownership rights to their unit and the right to share the common elements of the condominium development with other co-owners. The condominium subdivision plan, which is part of the master deed, identifies which areas are units and which areas are common elements.

The co-owners own and maintain the development once the developer has sold all the units, unless the local government agrees to take responsibility for maintaining a portion of the development. Roads are an example of a portion of a condominium development that may become public.

The master deed provides the percentage of ownership for each condominium unit in the development. This percentage is the basis for determining your obligation for payment of monthly maintenance fees, assessments for major repairs, and may determine your voting percentage at association meetings. The association of co-owners determines how much the monthly maintenance fee will be and assesses each owner for repairs to the common elements.

## **READ THE BYLAWS**

Read the bylaws for the association and condominium development as they contain provisions outlining your rights and obligations as a co-owner.

You are obligated to pay the monthly maintenance fee and any assessments. If there are no restrictions in the bylaws that place limits on increasing the monthly fee, the association has the right to determine the amount. If the roads, or any other portion of the common elements in the development need repair, the association will determine the amount each owner is responsible for paying. If there are no restrictions in the bylaws regarding assessments, the association has the right to determine the amount. If you fail to pay an assessment or monthly fee, the association may place a lien on your unit.

Modifications or repairs to your unit may require approval of the co-owners association. If you do not obtain approval, the association may take legal action against you.

Before signing a purchase agreement, you should be aware of any restrictions on pets, renting, displaying items outdoors, and other prohibitions in the bylaws. Even if a restriction is not in the bylaws when you purchase, the association may amend the bylaws. Only changes that materially affect the co-owners require a vote of all co-owners.

You may not have the right to attend association meetings unless the bylaws specify that you may attend. The bylaws may not require associations to provide minutes of their meetings to co-owners.



## **PRELIMINARY RESERVATION AGREEMENTS**

A preliminary reservation agreement gives you the opportunity, for a specified time, to purchase a particular condominium unit upon sale terms to be determined later. The developer must place the payment you make in an escrow account with an escrow agent. If you make a payment under a preliminary reservation agreement and cancel the agreement, the developer must fully refund the money. If you enter into a purchase agreement, the developer must credit the payment toward any payment due in the purchase agreement.

## **PURCHASE AGREEMENTS**

**A purchaser may withdraw from a signed purchase agreement without cause or penalty within nine business days** as long as the property has not been conveyed to the purchaser. The nine-business day window starts the day the purchaser receives all the documents that the developer is required to provide. The developer must deposit payments made under a purchase agreement in an escrow account with an escrow agent.

Before signing an agreement, it is advisable to seek professional assistance to review all condominium documents.

### **Some issues to consider before buying include the following:**

- **Do not rely on verbal promises** - insist that everything be in writing and signed by the appropriate parties involved in the transaction.
- The bylaws may contain a variety of restrictions. You may be required to receive association approval for certain actions. If you do not obtain prior approval, the association has authority to enforce the legal restrictions in the bylaws.
- You may be subject to a binding purchase agreement before construction is complete. Determine whether the agreement will provide you with adequate rights if the developer does not finish the unit in time to meet the occupancy date.
- You may wish to contact the local government to determine if the developer is contractually obligated to finish the development.
- Review all restrictions, covenants, and easements that might affect the condominium project or your unit.
- Determine if the developer has reserved any rights to alter the project.
- Before signing a purchase agreement, make sure you have financing, or that the agreement specifies it is dependent on your ability to obtain a mortgage commitment for the unit.
- When buying a condominium unit in a structure, you may also be a joint owner of the furnace, roof, pipes, wires and other common elements. Ask for an architect's or engineer's report on the condition of all building components, their expected useful life and building maintenance records.

- There is no governmental agency that regulates condominium associations and management companies. Only a judge has authority to order an association to comply with the Condominium Act and bylaws.

## **DOCUMENTS THE DEVELOPER MUST PROVIDE**

The developer must provide copies of the following documents to a prospective purchaser:

1. The recorded master deed.
2. A copy of the purchase agreement and the escrow agreement.
3. This condominium buyer's handbook.
4. A disclosure statement that includes:
  - The developer's previous experience with condominium projects.
  - Any warranties undertaken by the developer.
  - The extent to which financial arrangements have been provided for completion of all structures and improvements labeled "must be built" on the subdivision plan.
  - An itemization of the association's budget.

## **ASSOCIATION OF CO-OWNERS (CONDOMINIUM BOARD)**

Initially, the developer appoints the board of directors, who govern the development until the first annual meeting. The provisions for holding the annual meeting and designating the voting procedures should be included in the condominium development bylaws. The Condominium Act, (Section 52), describes the procedure for transitioning from the developer to the association of co-owners for the governing of the development. (Also see "Election of Association of Co-owners Board of Directors" later in this handbook.)

The co-owners elect the association, which is responsible for governing the development and maintaining the general common elements. The general common elements may consist of hallways, lobbies, building exteriors, lawns, streets (if the roads are private), recreation facilities, heating, water and electric systems. The association may hire a management company to provide services for the development. They also have the right to assess co-owners for repairs. After the creation of the association, the association may adopt bylaws for the operation of the association. Rules governing the condominium development are in the bylaws that the developer created for the condominium development.

A condominium association is a private, not public entity. Meetings of the association are not subject to the Open Meetings Act, which requires public agencies to make attendance at meetings open to the public and requires the provision of minutes that describe actions taken at the meeting.

Associations are required by law to keep books and records with a detailed account of the expenditures and receipts affecting the project and its administration, and which specify the operating expenses. The developer must provide a disclosure

statement itemizing the association's budget at the time you receive the master deed.

Associations are required to maintain a reserve fund for major repairs and replacement of common elements. The minimum amount is 10% of the annual budget on a non-cumulative basis. If the association needs additional funds for major repairs, they may have the right to assess each owner. Monthly fees and assessments are a lien on the condominium unit. You may not be exempt from monthly fees and assessments by nonuse of the common elements or by abandonment of the condominium unit.

If you have a complaint with the association or other co-owners, review the condominium bylaws to determine what recourse you have. Generally, only professional arbitrators or the courts have jurisdiction over complaints between these parties.

### **DOCUMENTS THE ASSOCIATION MUST PROVIDE**

The association must provide a financial statement annually to each co-owner. The books, records, and contracts concerning the administration and operation of the condominium project must be available for examination by any of the co-owners at convenient times. An association with annual revenues more than \$20,000 shall have its books, records, and financial statements independently audited or reviewed by a certified public account on an annual basis. However, such an association may opt out of the requirement for an independent audit or review by a certified public account by an annual affirmative vote. The association must keep current copies of the master deed, all amendments to the master deed, and other condominium documents available at reasonable hours to co-owners, prospective purchasers and prospective mortgagees.

### **SITE CONDOMINIUMS**

The term "site condominium" is not legally defined in the Condominium Act. It is used to describe a condominium development with single-family detached housing instead of two or more housing units in one structure.

Site condominium developments must comply with the Act. The Act requires developers to notify the appropriate local government of their intent to develop a condominium project. The type of review the development is subject to depends on the local government's ordinances. Site condominium documents are not reviewed by the State for conformance with the Condominium Act.

Another type of single-family-residential housing development in Michigan is a subdivision which is regulated according to the Land Division Act. Although a site condominium development may look like a subdivision developed in accordance with the Land Division Act, they are not the same. Subdivisions developed pursuant to the Land Division Act are subject to state review for conformance with the Land

Division Act. Subdivisions developed pursuant to the Land Division Act must be approved for compliance with the Land Division Act before the developer may sell any real estate.

### **LIMITED OR GENERAL COMMON ELEMENTS**

Common elements mean the portions of the condominium project other than the condominium unit. Limited common elements are areas with usage restrictions. A carport space assigned to a unit is a limited common element. The yard of a single family detached unit, for use by the owner of that unit, may be a limited common element. General common elements such as roads, open space areas and recreation facilities are available for use by everyone in the development. The master deed specifies which areas of your condominium development are designated as limited or general common elements. Use of the common elements is governed by the bylaws for the condominium development.

### **ADVISORY COMMITTEE**

The advisory committee is established when one of the following occurs, whichever happens first: 120 days after 1/3 of the units are sold or one year after a unit is sold to a non-developer co-owner.

The purpose of the advisory committee is to meet with the development's board of directors to facilitate communication and aid in the transition of control from the developer to the association of co-owners. The advisory committee ceases when a majority of the association of co-owners is elected by the (non-developer) co-owners.

### **ELECTION OF ASSOCIATION OF CO-OWNERS BOARD OF DIRECTORS**

No later than 120 days after 25% of (non-developer) co-owners have title to the units; that may be created, at least one director, and not less than 25% of the board of directors shall be elected by the co-owners.

No later than 120 days after 50% of (non-developer) co-owners have title to the units that may be created, at least one third of the board of directors shall be elected by the co-owners.

No later than 120 days after 75% of (non-developer) co-owners have title to units, and before 90% are sold, the co-owners shall elect all but one director on the board. The developer shall have the right to designate one director only if the developer owns and offers for sale at least 10% of the units, or as long as 10% of the units remain to be created.

If titles to 75% to 100% of the units that may be created have not been sold 54 months after the first conveyance, the (non-developer) co-owners shall elect the number of board members equal to the percentage of units they hold. If the

developer has paid all assessments, the developer has the right to elect the number of board members equal to the percentage of units that are owned by the developer.

## **CONDOMINIUM DOCUMENTS**

The condominium documents include the master deed, condominium subdivision plan, bylaws for the condominium project, and any other documents referred to in the master deed or bylaws. In addition, the developer is required to provide a disclosure statement.

Once the association is established, it may adopt another set of bylaws pertaining to the association's operation. The association or management company must keep books and records with a detailed account of the expenditures and receipts affecting the project and its administration, and which specify the operating expenses.

## **AMENDMENTS TO CONDOMINIUM DOCUMENTS**

If the condominium documents contain a statement that the developer or association of co-owners has reserved the right to amend the documents for that purpose, then the documents may be amended without the consent of the co-owners, as long as the change does not materially alter or change the rights of a co-owner.

The master deed, bylaws and condominium subdivision plan may be amended, even if the amendment will materially alter or change the rights of a co-owner with the consent of at least 2/3 of the votes of the co-owners and mortgagees.

The method or formula used to determine the percentage of value of each unit for other than voting purposes cannot be modified without the consent of each affected co-owner.

A co-owner's condominium unit dimensions or limited common elements may not be modified without the co-owner's consent.

The association of co-owners may amend the condominium documents as to the rental of units or terms of occupancy. The amendment does not affect the rights of any lessors or lessees under a written lease executed before the effective date of the amendment, or condominium units that are owned or leased by the developer.

## **REMEDIES AVAILABLE PURSUANT TO THE CONDOMINIUM ACT**

A developer who offers or sells a condominium unit in violation of the Act is liable to the purchaser for damages.

A person or association of co-owners adversely affected by a violation of, or failure to comply with, the Act, the administrative rules issued under the authority of the Act, or any provision of an agreement or a master deed may take action in a court with jurisdiction. The court may award costs to the prevailing party.

A co-owner may take action against the association of co-owners to compel the association to enforce the condominium documents. To the extent that the condominium documents expressly provide, the court shall determine costs of the proceeding and the successful party shall recover those costs.

A co-owner may take action against another co-owner for injunctive relief or for damages for noncompliance with the terms of the condominium documents or the Act.

For condominium projects established on or after May 9, 2002, the bylaws must contain a provision that disputes relating to the interpretation of the condominium documents or arising out of disputes among co-owners may be resolved through arbitration. Both parties must consent to arbitration and give written notice to the association. The decision of the arbitrator is final and the parties are prohibited from petitioning the courts regarding that dispute.

A co-owner, or association of co-owners, may execute a contract to settle by arbitration for any claim against the developer that might be the subject of a civil action. A purchaser or co-owner has the exclusive option to execute a contract to settle by arbitration for any claim against the developer that might be the subject of a civil action and involves less than \$2,500. All costs will be allocated in the manner provided by the arbitration association. A contract to settle by arbitration must specify that the arbitration association will conduct the arbitration. The method of appointment of the arbitrator will be pursuant to rules of the arbitration association. Arbitration will be in accordance with Public Act No. 236 of 1961, (MCL 600.5001 to 5065), which may be supplemented by rules of the arbitration association. An arbitration award is binding on the parties to the arbitration.

The Condominium Act provides the right to notify the governmental agency that is responsible for the administration and enforcement of construction regulations of an alleged violation of the state construction code, other applicable building code, or construction regulation.

A person who willfully and knowingly aids in misrepresentation of the facts concerning a condominium project, as described in the recorded master deed, is guilty of a misdemeanor and shall be punished by a fine, imprisonment, or both. Actions under MCC 559.258 shall be brought by the prosecuting attorney of the county in which the property is located, or by the department of attorney general.

A person can not take action arising out of the development or construction of the common elements, or the management, operation, or control of a condominium project, more than three years from the transitional control date or two years from the date of the cause of the action, whichever occurs later. The transitional control date is the date the board of directors takes office by an election where the co-owners' votes exceed the developer's votes for the board members.

A condominium developer may be required to be a licensed residential builder under the Occupational Code (PA 299 of 1980, Article 24, as amended). A complaint for a violation of the **Michigan Occupational Code** or administrative rules, must be made within 18 months after completion, occupancy, or purchase of a residential structure. Conduct subject to penalty is described in the Occupational Code (MCL 339.2411). Complaints concerning construction may be filed with:

Michigan Department of Licensing and Regulatory Affairs  
Bureau of Professional Licensing  
Enforcement Division  
P. O. Box 30018  
Lansing, MI 48909  
Phone: (517) 373-8068  
[www.michigan.gov/lara](http://www.michigan.gov/lara)

**LEGAL REFERENCES**

Condominium Act, P.A. 59 of 1978, as amended, MCL 559.101 et seq.  
Condominium Rules, R559.101 et seq, 1985 Michigan Admin Code.  
Occupational Code, P.A. 299 of 1980, as amended, MCL 339.101 et seq.  
Stille-DeRossett-Hale Single State Construction Code Act, P.A. 230 of 1972, as amended, MCL 125.1501 et seq.