

7135 W Buffalo Rd  
Churchville, NY 14428

**DOLLAR GENERAL**



LISTING BROKER

Jennifer Stein Real Estate, Inc.

Jennifer Stein

P: (213) 446-5366

JStein@JenniferStein-RealEstate.com

NY Lic No: 10311209861

OUT OF STATE COOPERATING BROKER

MARIO GANDARA JD, MBA

Principal

P: (310) 210-5789

mario@socalcoastalcapital.com

License CA 01898787

[www.socalcoastalcapital.com](http://www.socalcoastalcapital.com)

**7135**

**W Buffalo Rd.**







# EXECUTIVE SUMMARY

We are pleased to present for sale a retail, single tenant property in Churchville, New York. The lease is backed by Dollar General, a NYSE-listed company (NYSE: DG) with a strong Moody's rating (Baa2), offering a NN (Double Net) lease structure for passive income with minimal landlord responsibilities including structure and roof. The remaining lease term is approximately five years with one 5-year option at a 5% rent escalation. This attractive offering is a 6.26% cap rate.



## Offering Summary

Property Address	7135 W Buffalo Rd
Property Type	Retail
Building Class	C
Building Size	9,001 SF
Land Acres	5.30 AC
Year Built	2006
Tenancy	Single
Parking	40 spaces

# Property Overview



Price

\$975,000



Cap Rate

6.26%



NOI

\$61,008

Lease Commencement Date:	03/23/2004
Years Remaining:	~5 years
Renewal Options:	One 5-year
Rental Escalation:	5%
Lease Type:	NN
Tenant:	Dollar General
Landlord Responsibility	Roof & Structure
Guaranty:	Corporate
Year Built:	2006
Building Size:	9,001 SF
Land Size:	5.30 AC

<u>Term</u>	<u>Date</u>	<u>Rent</u>	<u>Cap Rate</u>
3rd Option	10/1/24 - 5/31/29	\$5,084	6.26%
4th Option	06/1/29 - 5/31/34	\$5,334	6.56%





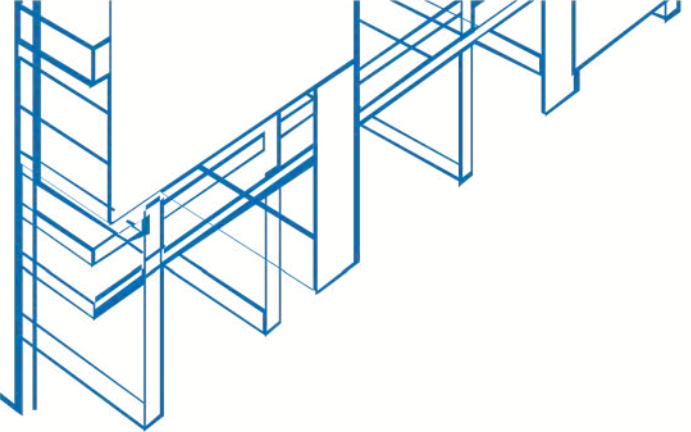

# TENANT OVERVIEW

**B B B**

INVESTMENT GRADING

**21,000+**

NO. OF LOCATIONS

**163,000**

EMPLOYEES

## Market Overview

Dollar General is the fastest-growing retailer which currently boasts roughly 21,000 neighborhood general stores in 46 US states, primarily in the South, East, Midwest, and the Southwest. Roughly 75% of Dollar General's sales are derived from consumables (including refrigerated, shelf-stable, and perishable foods,) in addition to everyday household items such as paper towels, bath tissues, paper dinnerware, laundry, and home cleaning supplies.

Dollar General offers some of America's most trusted name brands such as Clorox, Energizer, Procter & Gamble, Hanes, Coca-Cola, Mars, Nestlé, Kimberly-Clark, Kellogg's, General Mills, Pepsi, and many others. Over the past few years, Dollar General has started to introduce alcohol and tobacco products such as cigarettes into their product mix, which has further driven revenue and increased profitability.

With its small-box store model typically measuring ± 9,100 sq. ft, Dollar General targets cost-conscious consumers that prefer easier and quicker access to items than at super-sized competitors such as Wal-Mart and Costco (which are also often much farther away). Indeed, Dollar General's strategy of catering to the value-conscious has paid off big, both during and after the recession.

Dollar General is planning approximately 2,385 real estate projects for fiscal year 2024, including about 800 new store openings (including approximately 30 popshelf openings and 15 new stores in Mexico), along with 1,500 store renovations and 85 store relocations.



# LOCATION DESCRIPTION

Churchville is a village in Monroe County, New York, United States. According to the 2010 census, the population was 1,961. The village is named after Samuel Church, an early settler. The village is west of the City of Rochester in the north part of the Town of Riga. More specifically, Churchville is located within Rochester MSA, which is a heavily populated area. As of the 2020 census, the MSA for Rochester had a population of 1,090,135. The Rochester MSA is the 4th largest MSA in New York state. With the cities of Rochester, Buffalo and Syracuse, the Erie Canal, Lake Ontario, the Finger Lakes, and numerous world-class museums and colleges just short drives away, the Village of Churchville is a gateway to everything that makes western New York great.

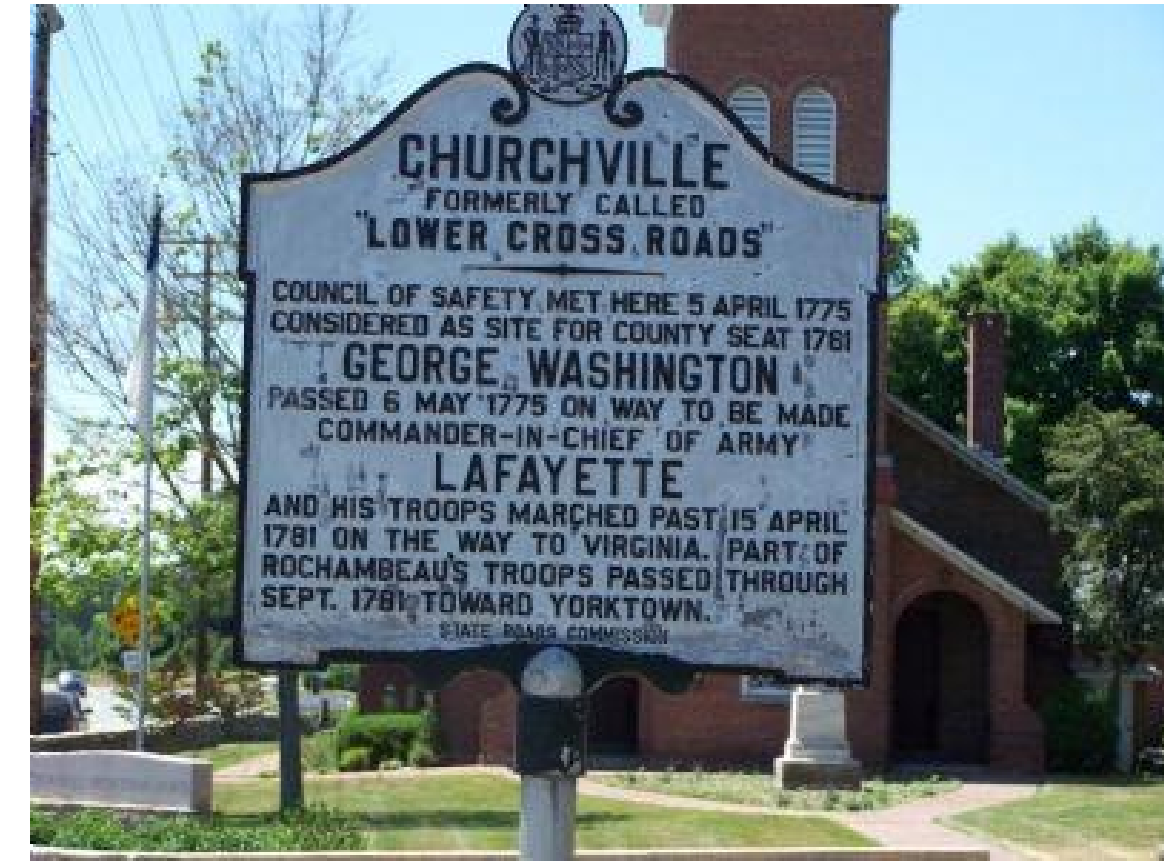





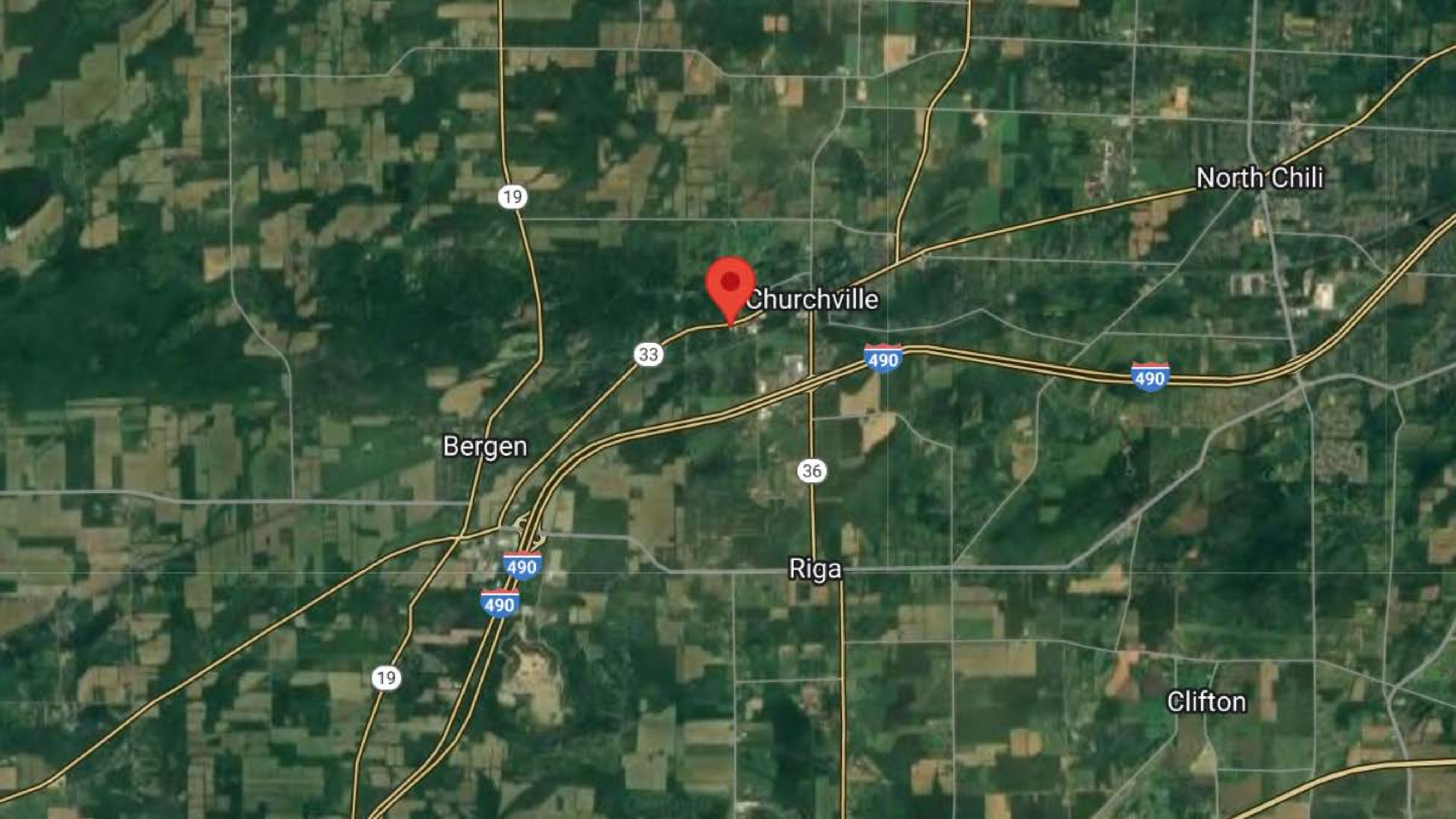

North Chili

Churchville

Bergen

Riga

Clifton

19

33

490

490

36

490

490

19



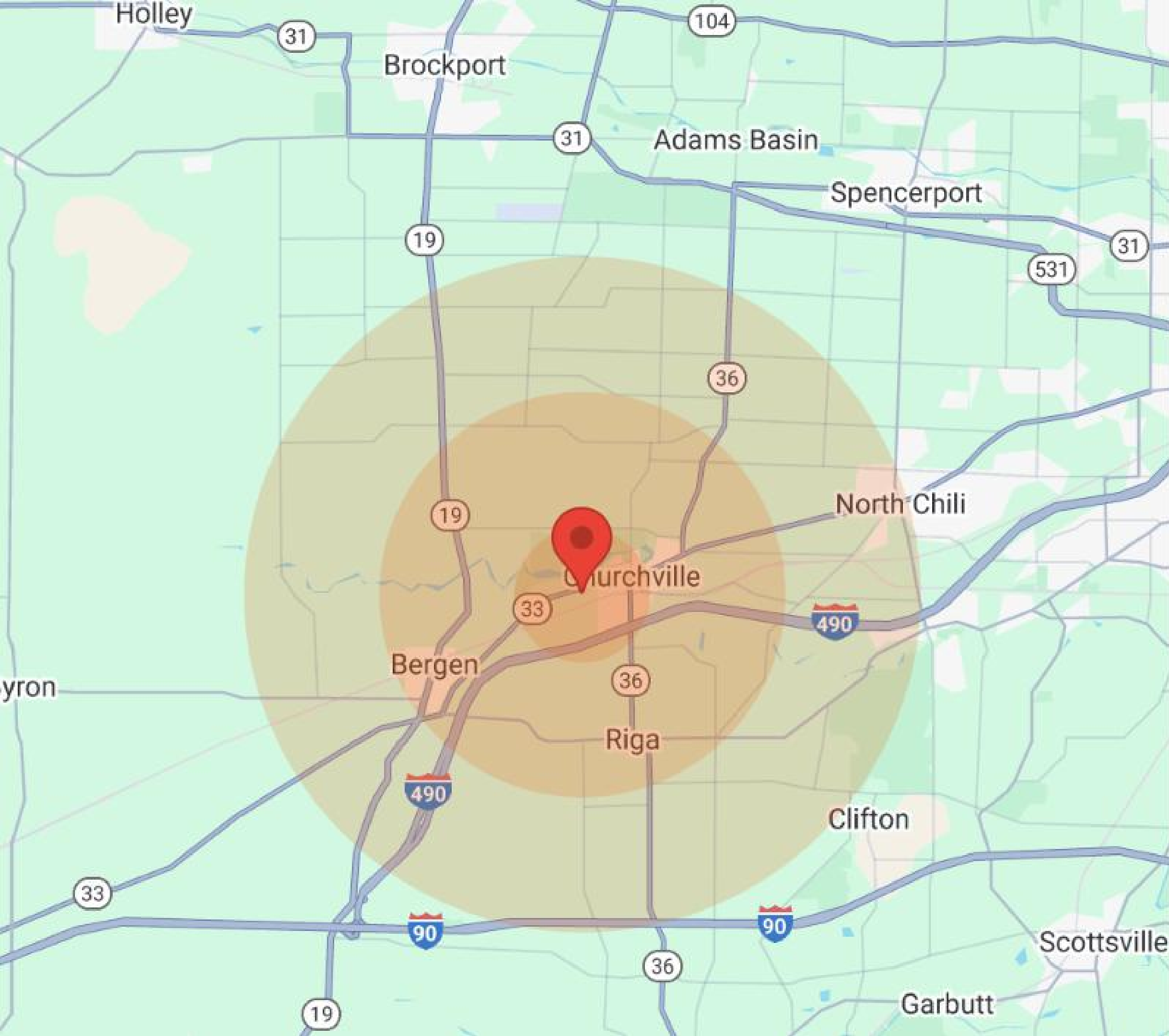

Population	1 Mile	3 Miles	5 Miles
Male	639	2,952	5,988
Female	631	2,963	6,108
Total Population	1,270	5,915	12,096

Age	1 Mile	3 Miles	5 Miles
Ages 0-14	218	973	1,945
Ages 15-24	200	843	1,708
Ages 25-54	547	2,316	4,759
Ages 55-64	172	884	1,793
Ages 65+	133	899	1,891

Race	1 Mile	3 Miles	5 Miles
White	1,266	5,864	11,893
Black	N/A	1	68
Am In/AK Nat	N/A	N/A	N/A
Hawaiian	N/A	N/A	N/A
Hispanic	5	43	102
Multi-Racial	8	88	238

Income	1 Mile	3 Miles	5 Miles
Median	\$60,714	\$63,100	\$61,907
< \$15,000	64	153	347
\$15,000-\$24,999	35	197	422
\$25,000-\$34,999	45	229	383
\$35,000-\$49,999	60	262	487
\$50,000-\$74,999	88	558	1,103
\$75,000-\$99,999	79	360	776
\$100,000-\$149,999	67	410	854
\$150,000-\$199,999	18	62	132
> \$200,000	16	23	85

Housing	1 Mile	3 Miles	5 Miles
Total Units	468	2,148	4,427
Occupied	452	2,067	4,260
Owner Occupied	342	1,736	3,564
Renter Occupied	110	331	696
Vacant	16	81	167





**LISTING BROKER**

Jennifer Stein Real Estate, Inc.

Jennifer Stein

P: (213) 446-5366

JStein@JenniferStein-RealEstate.com

NY Lic No: 10311209861

**OUT OF STATE COOPERATING BROKER**

MARIO GANDARA JD, MBA

Principal

P: (310) 210-5789

mario@socalcoastalcapital.com

License CA 01898787

[www.socalcoastalcapital.com](http://www.socalcoastalcapital.com)

