



HIGHLIGHTS

- Good signage
- Close freeway access
- Lots of on-Site Parking
- New parking lot
- Brick building
- Close to several popular restaurants

9212 E. Montgomery
Spokane Valley, WA
AVAILABLE SUITES

Suite: 501: 1,115 sq.ft.
\$1,200.00 per month
plus NNN

Suite: 502: 940 sq.ft.
\$1,075 per month
plus NNN



FOR LEASE

Levi McCormick:
O: 509.462.9306
levi@sdsrealt.com

Carlos Herrera
C: 509.714.2593
carlos@sdsrealty.com

Suite 501

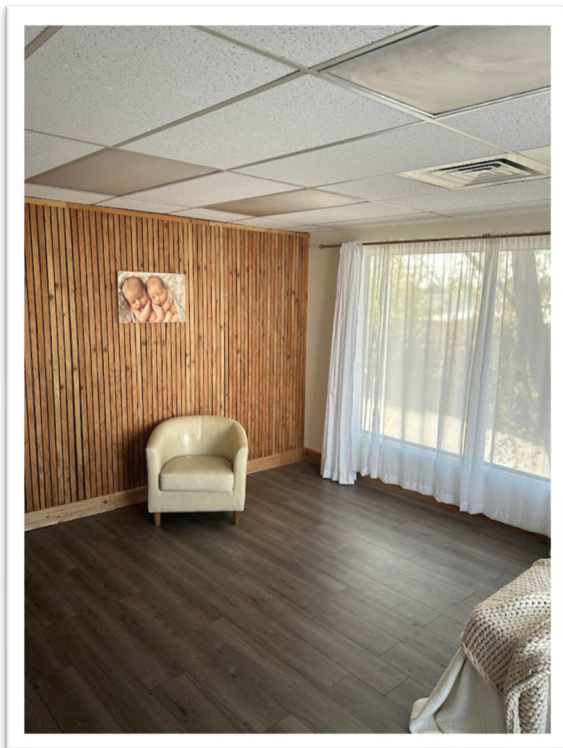
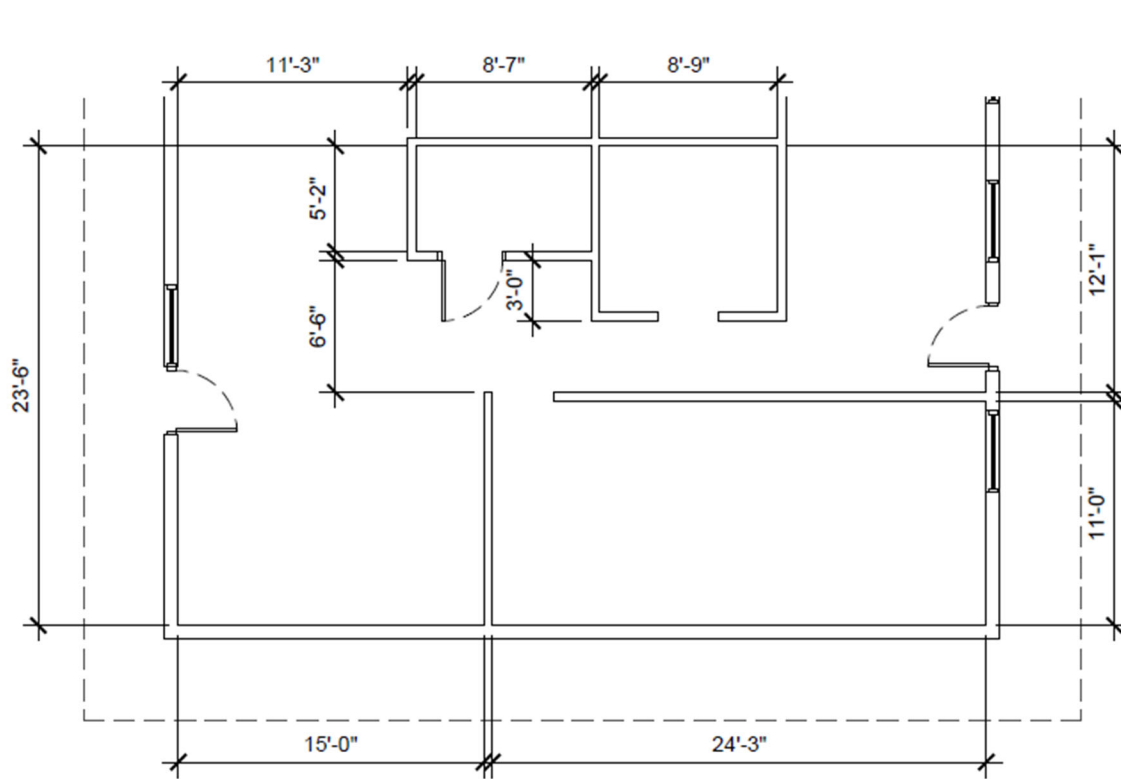



FOR LEASE

Levi McCormick:
O: 509.462.9306
levi@sdsrealty.com

Carlos Herrera
C: 509.714.2593
carlos@sdsrealty.com

Suite 502

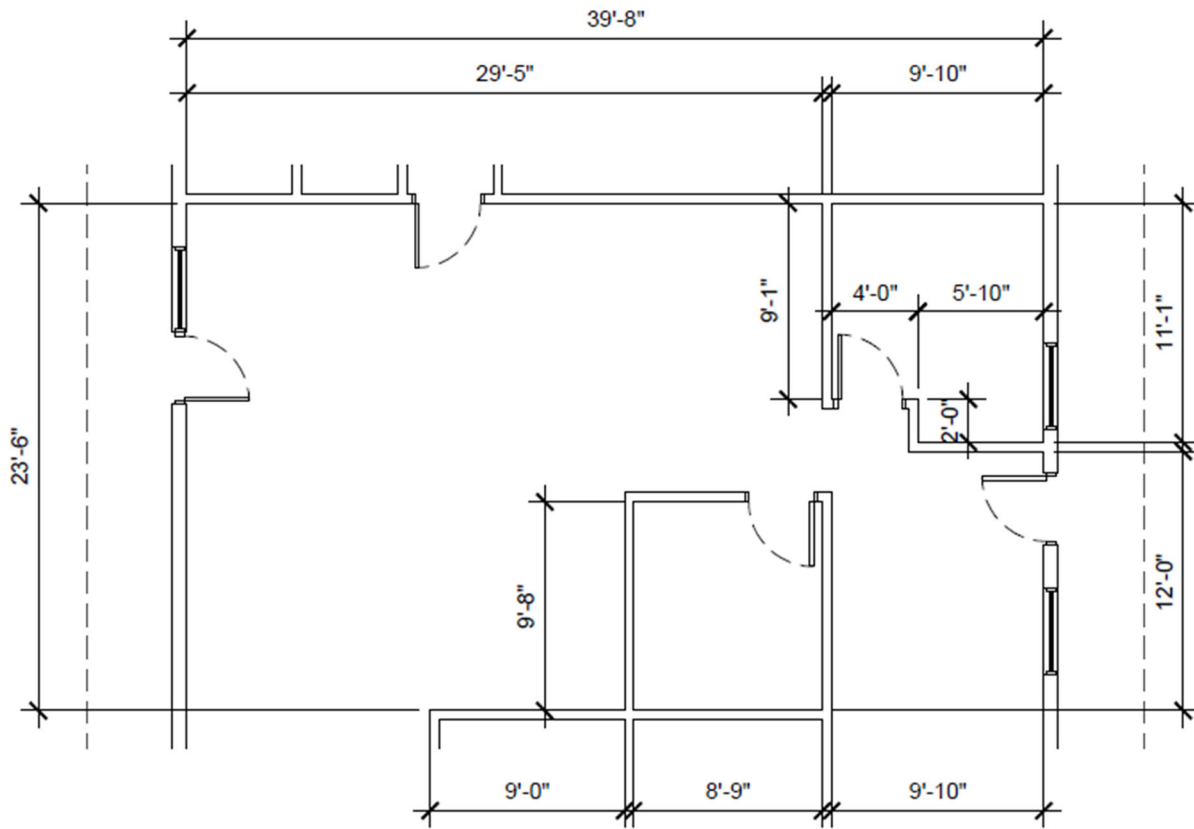

12 (010 SOFT)