



AIRPORT 85 BUSINESS PARK

2732 INTERSTATE STREET, CHARLOTTE, NC

AVAILABLE
MARCH 2026

2732 Interstate Street, Suite G
3,625 SF Dock High - Dock Height

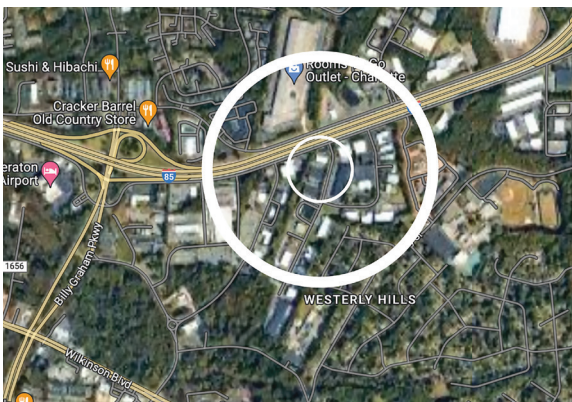

- Office | Flex | Distribution
- Minutes to Airport, I-85, Billy Graham Pkwy / I-485
- 16' 5" Clear Height in Warehouse zoned I-1
- Ideal for technical service, back office operation
- Ample parking, Security lighting and gas heating in warehouse
- Minutes away from Sheraton, Marriott's Springhill Suites, and Comfort Suites
- Norfolk Southern Intermodal Terminal in close proximity (see attached map)

AVAILABLE



SUITE G

3,625 sq. ft.

2732 Interstate Street
Suite G, Charlotte, NC

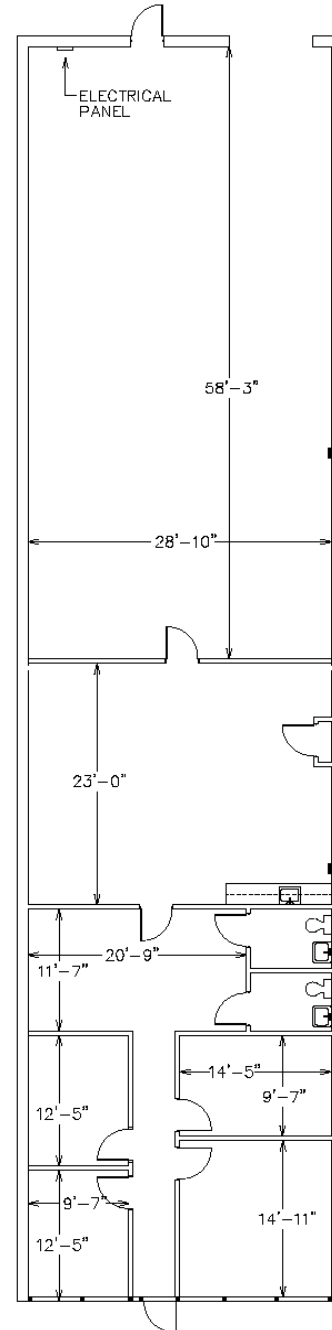

AIRPORT 85 BUSINESS PARK

2732 Interstate St. Charlotte NC

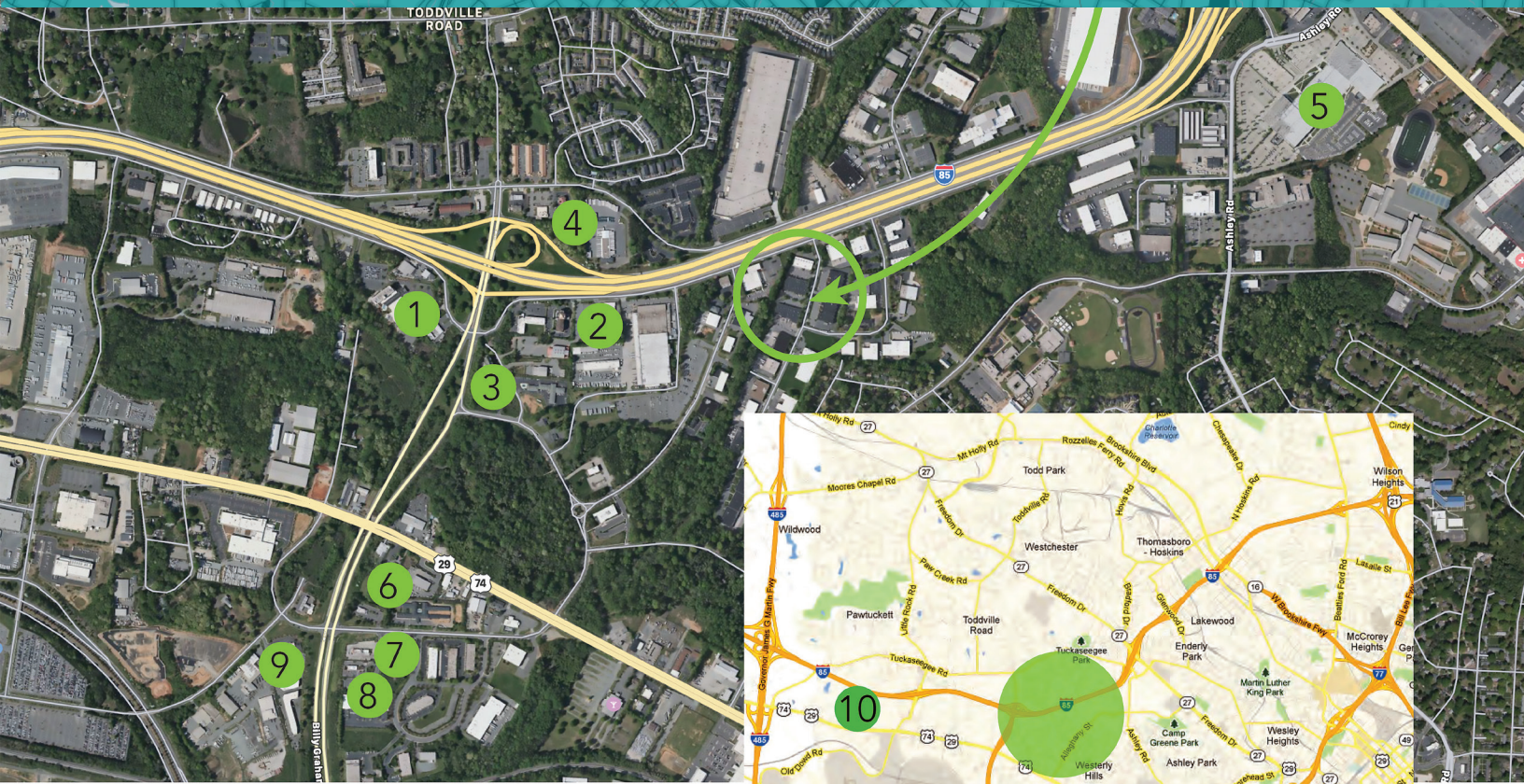

LOCATED NEARBY

- 1 Sheraton Hotel
- 2 Springhill Suites by Marriott
- 3 Comfort Suites
- 4 Cracker Barrel
- 5 Meck County Services Building
- 6 Wendy's
- 7 McDonald's
- 8 KFC / Taco Bell
- 9 Bojangles'
- 10 Charlotte Inland Terminal

ADVANTAGES

- Office | Flex | Distribution
- 3,000 - 5,000 sq ft bays
- Dock High Door & Ramps Available
- 16' - 5" Clear Height in Warehouse Zoned I-1
- Minutes from Charlotte Douglas International Airport, I-85, I-485, I-77 and Billy Graham Pkwy
- Charlotte Inland Terminal Intermodal Port