

NOW LEASING

Preferred
Real Estate Partners



2211
MAIN ST
Waller, TX 77484



FLOOR PLAN

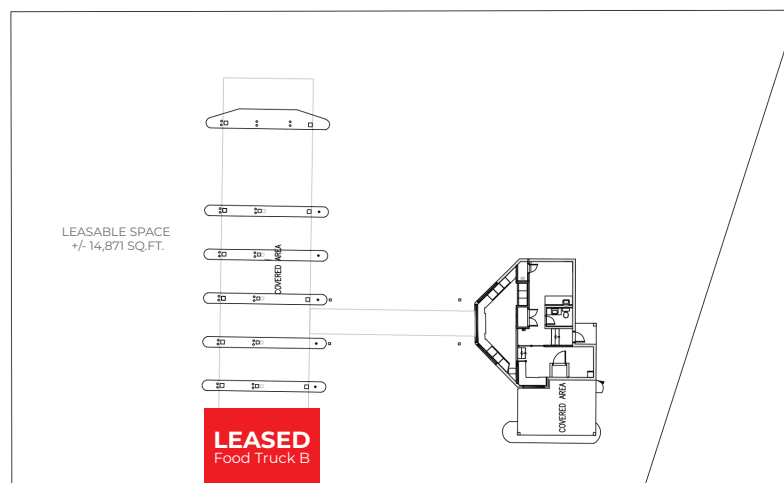

LEASE INFORMATION

Term: 6 months min.

SUITE	DESCRIPTION
Suite A +/- 4,556 SF	As is
Food Truck B	LEASED
Food Truck C	As is
Food Truck D	As is
Food Truck E	As is
Food Truck F	As is

DISCLAIMER: These numbers reflect what is currently available for lease and do not describe the total square footage



FLOOR PLAN

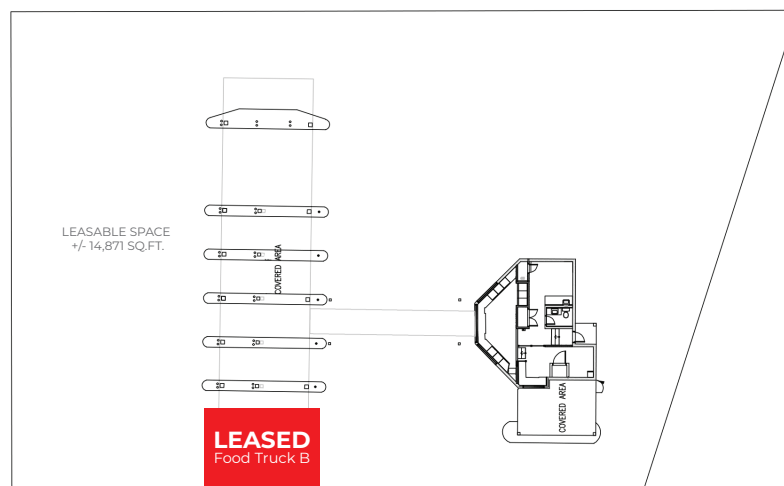

LEASE INFORMATION

Term: 6 months min.

SUITE	DESCRIPTION
Food Truck G	As is
Food Truck H	As is
Food Truck I	As is
Food Truck J	As is
Food Truck K	As is
Food Truck L	As is

DISCLAIMER: These numbers reflect what is currently available for lease and do not describe the total square footage

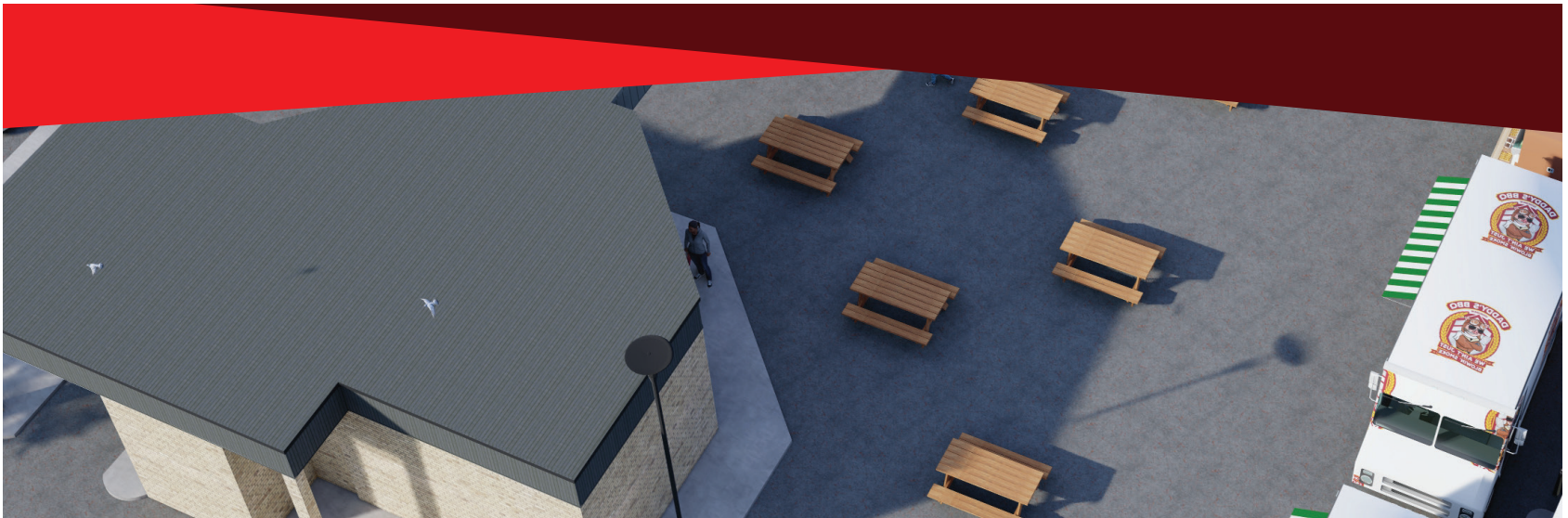

PROPERTY HIGHLIGHTS

11 Food Truck Spots

Drive-Thru

Just off Business 290

High Traffic

OFFERING SUMMARY Call for pricing



CONTACT US

Head Office

31406 Farm to Market 2920 Suite B201,
Waller, TX 77484

936-213-9481

Moreinfo@Preferred-Realty.com

Inquiries

For any inquiries, questions
or recommendations,
please call: 936-231-9481

2311
MAIN ST

Preferred
Real Estate Partners