

FOR LEASE

Medical and Office Suites

TENLEY BUILDING

50 West Edmonston Drive
Rockville, Maryland 20852

**Newly Renovated
Lobby,
Elevator Cabs,
Common Areas and
Bathrooms!**



**Spec Suites Available ♦ Free Surface Parking!
Lease Term: 3-10 Years**

Located just steps from numerous restaurants and all of Rockville Pike's amenities, the Tenley Building features local ownership, onsite banking, cleaners, pharmacy, optician and FREE parking! Additional features include operable windows, storage, and individual suite Datawatch access control.

***This building is located at the corner
of West Edmonston Drive and
Rockville Pike with convenient
access to I-270.***

For more details please contact:

301.961.9696

**John C. Alexander - Ext. 207
jalexander@amrcommercial.com**

AMR
COMMERCIAL, L.L.C.
ALEXANDER, MONTROSE, RITTENBERG
Commercial Real Estate Brokerage
Est. 1994

Celebrating
30
Years
1994-2024

A Member of **CORE**
COMMERCIAL REAL ESTATE

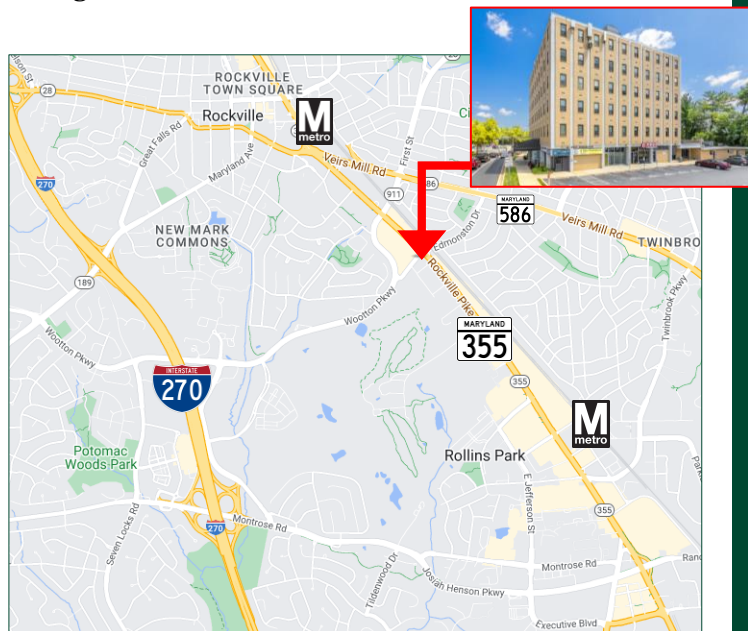

4849 Rugby Avenue ♦ Suite 200 ♦ Bethesda, Maryland 20814 ♦ 301.961.9696 ♦ Fax 301.656.7551

Although all information furnished is from sources we deem reliable, such information has not been verified and no express representation is made nor is any to be implied as to the accuracy thereof, and it is submitted subject to errors, omissions, or other conditions.

"C:\Users\RobynFunkhouser\AMR Commercial\AMR Commercial Team Site - Shared Documents\Property Profiles & Flyers\Property Flyers\Tenley Flyers\50 W Edmonston TENLEY Lease Flyer, All Available-jca 09172024.pptx"

TENLEY BUILDING
50 W. Edmonston Drive
Rockville, MD 20852

Suite 402
980 R.S.F.

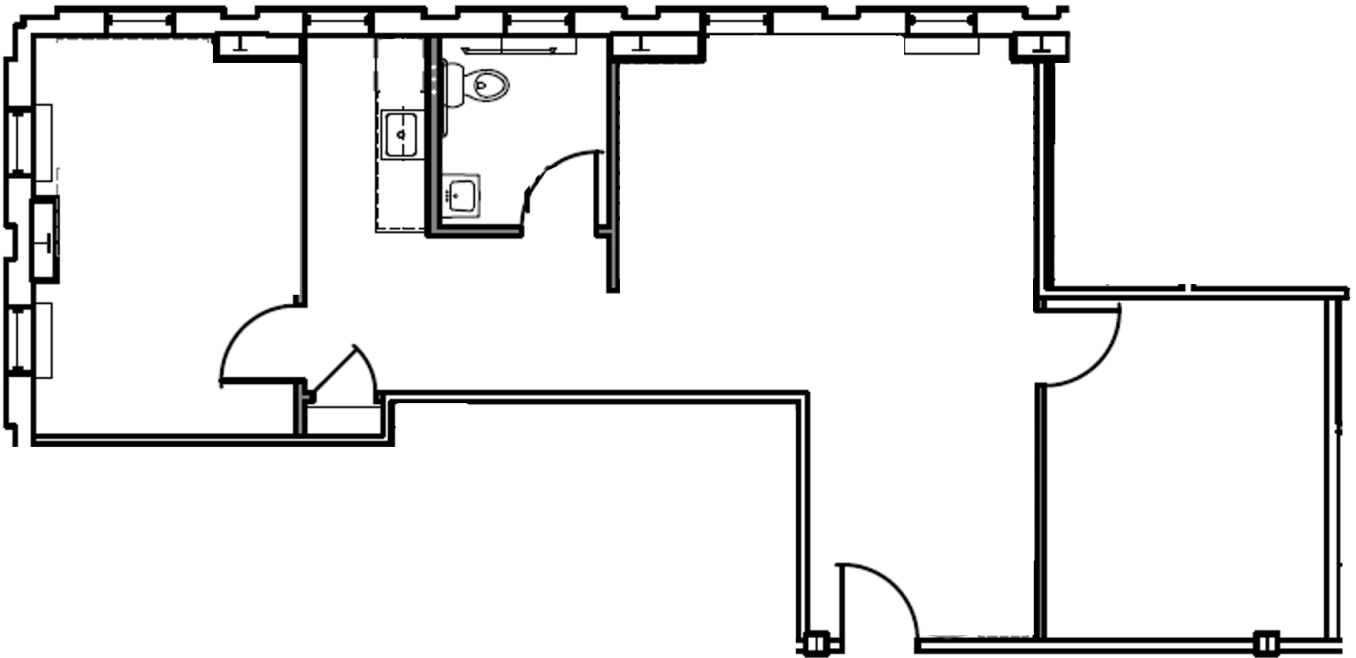

NOT TO SCALE | MEASUREMENTS APPROXIMATE

Although all information furnished is from sources we deem reliable, such information has not been verified and no express representation is made, nor is any to be implied, as to the accuracy thereof, and it is submitted subject to errors, omissions, changes of price/rental or other conditions prior to sale or lease, and subject to withdrawal without notice.

TENLEY BUILDING
50 W. Edmonston Drive
Rockville, MD 20852

Suite 504
1,070 R.S.F.

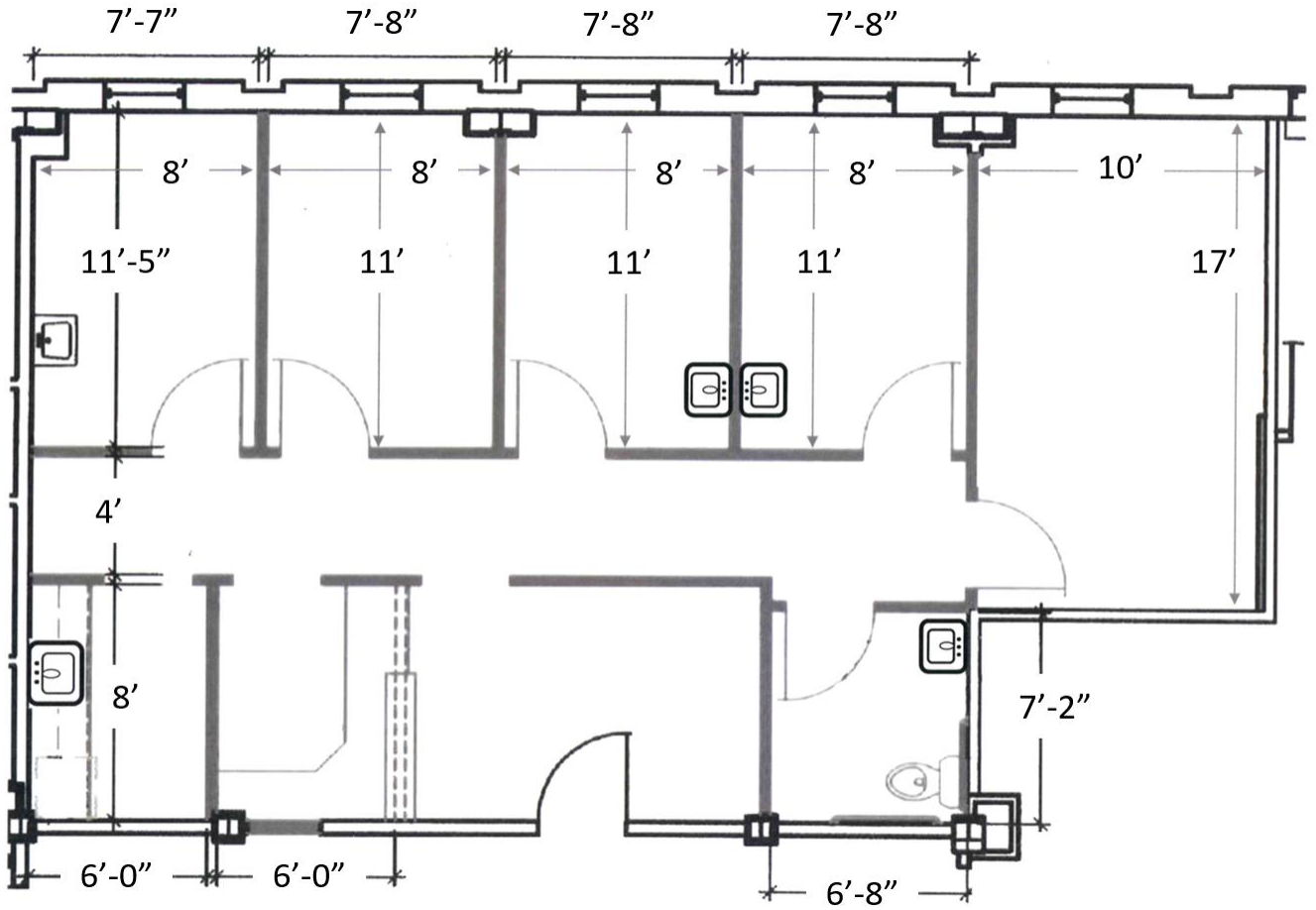

NOT TO SCALE | MEASUREMENTS APPROXIMATE

Although all information furnished is from sources we deem reliable, such information has not been verified and no express representation is made, nor is any to be implied, as to the accuracy thereof, and it is submitted subject to errors, omissions, changes of price/rental or other conditions prior to sale or lease, and subject to withdrawal without notice.

TENLEY BUILDING
50 W. Edmonston Drive
Rockville, MD 20852

Suite 602
1,730 R.S.F.

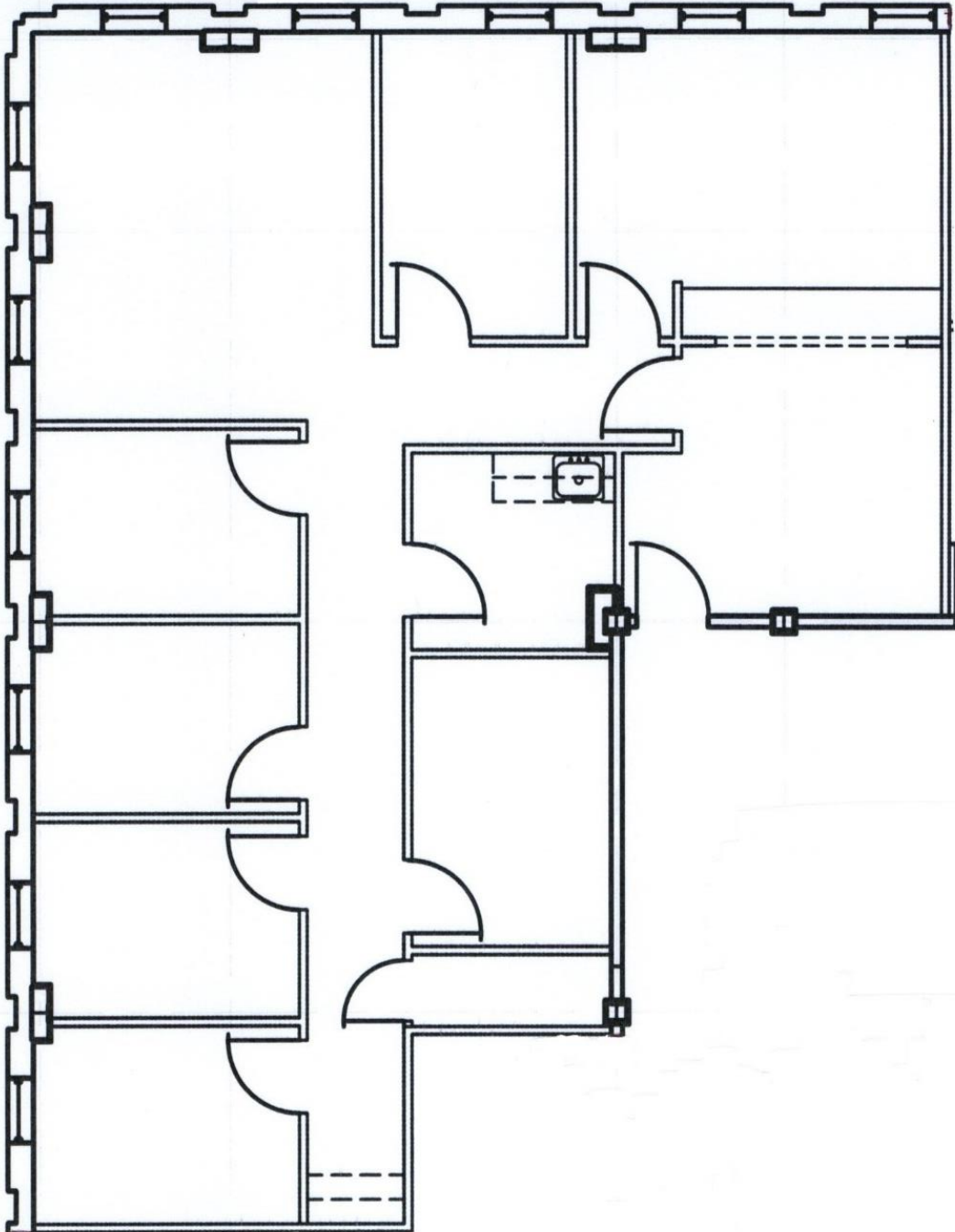

NOT TO SCALE | MEASUREMENTS APPROXIMATE

Although all information furnished is from sources we deem reliable, such information has not been verified and no express representation is made, nor is any to be implied, as to the accuracy thereof, and it is submitted subject to errors, omissions, changes of price/rental or other conditions prior to sale or lease, and subject to withdrawal without notice.